

Candidate Name: _____ Index No: _____ Class: _____

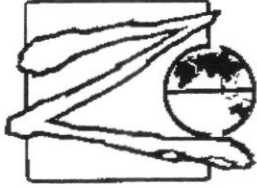

**ZHENGHUA SECONDARY SCHOOL
PRELIMINARY EXAMINATIONS 2023
SECONDARY FOUR EXPRESS/NORMAL (ACADEMIC) (O LEVEL)
MATHEMATICS
Paper 1**

4052/01

22 AUGUST 2023

Candidates answer on the Question Paper.

2 hours 15 minutes

*Zhenghua Secondary School Zhenghua Secondary School Zhenghua Secondary School Zhenghua Secondary School
Zhenghua Secondary School Zhenghua Secondary School Zhenghua Secondary School Zhenghua Secondary School
Zhenghua Secondary School Zhenghua Secondary School Zhenghua Secondary School Zhenghua Secondary School
Zhenghua Secondary School Zhenghua Secondary School Zhenghua Secondary School Zhenghua Secondary School
Zhenghua Secondary School Zhenghua Secondary School Zhenghua Secondary School Zhenghua Secondary School*

READ THESE INSTRUCTIONS FIRST

Write your index number and name on all the work you hand in.

Write in dark blue or black pen.

You may use an HB pencil for any diagrams or graphs.

Do not use staples, paper clips, glue or correction fluid.

Answer **all** questions.

The number of marks is given in brackets [] at the end of each question or part question.

If working is needed for any question it must be shown with the answer.

Omission of essential working will result in loss of marks.

The total of the marks for this paper is 90.

The use of an approved scientific calculator is expected, where appropriate.

If the degree of accuracy is not specified in the question and if the answer is not exact, give the answer to three significant figures. Give answers in degrees to one decimal place.

For π , use either your calculator value or 3.142.

Name of Setter:

This document consists of 1 printed pages.

[Turn over]

Mathematical Formulae*Compound interest*

$$\text{Total amount} = P \left(1 + \frac{r}{100} \right)^n$$

Mensuration

$$\text{Curved surface area of a cone} = \pi r l$$

$$\text{Surface area of a sphere} = 4\pi r^2$$

$$\text{Volume of a cone} = \frac{1}{3} \pi r^2 h$$

$$\text{Volume of a sphere} = \frac{4}{3} \pi r^3$$

$$\text{Area of triangle } ABC = \frac{1}{2} ab \sin C$$

$$\text{Arc length} = r\theta, \text{ where } \theta \text{ is in radians}$$

$$\text{Sector area} = \frac{1}{2} r^2 \theta, \text{ where } \theta \text{ is in radians}$$

Trigonometry

$$\frac{a}{\sin A} = \frac{b}{\sin B} = \frac{c}{\sin C}$$

$$a^2 = b^2 + c^2 - 2bc \cos A$$

Statistics

$$\text{Mean} = \frac{\sum fx}{\sum f}$$

$$\text{Standard deviation} = \sqrt{\frac{\sum fx^2}{\sum f} - \left(\frac{\sum fx}{\sum f} \right)^2}$$

Answer **all** the questions.

1. Calculate $\frac{\sqrt[3]{4\pi^2 - 15^2}}{0.63}$.

Leave your answer to 4 decimal places.

Answer [1]

2. Factorise $9x^2 + 12x - 12$.

Answer [2]

3. The sine of an angle is 0.427.

Give two possible values for the angle.

Answer or [2]

4. 8 students took a test and their marks were recorded as follows.

8 10 9 13 10 9 x y

The modal score for the 8 students is 10 and the median is 9.5.

If the range of the scores is 5, and $x \leq y$, determine the values of x and y .

Answer $x = \dots\dots\dots$

$y = \dots\dots\dots$ [2]

5. A sum of money was shared among Allan, Ben and Chloe.

Allan receives $\frac{2}{5}$ of the money and the rest was shared among Ben and Chloe in the ratio 3:2.

Find the ratio of the money received in terms of Allan's : Ben's : Chloe's.

Answer $\dots\dots\dots : \dots\dots\dots : \dots\dots\dots$ [2]

6. John is making two rectangular flower beds.

The dimensions of the larger rectangle will be four times the dimensions of the smaller rectangle.

There is going to be the same depth of soil in each flower bed.

John needs 120 kg of soil for the larger flower bed.

Work out how much soil John needs for the smaller flower bed.

Answer kg [2]

7. $T = \sqrt{\frac{w}{d^3}}$ for a particular value of w and d .

If w is increased by 20%, and d is decreased by 10%, determine the percentage change in T .

Answer % [2]

8. Jamie is using the quadratic formula to solve a quadratic equation.

She substitutes values into the formula and correctly gets

$$x = \frac{-9 \pm \sqrt{81 - 48}}{6}$$

Find the quadratic equation that Jamie is solving, giving your answer in the form

$ax^2 + bx + c = 0$, where a , b and c are integers.

Answer [2]

- 9.

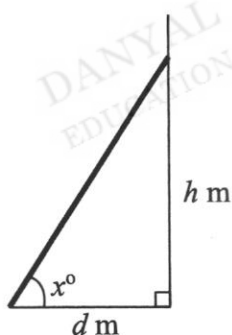

A ladder is leaning against a vertical wall as shown in the diagram.

The bottom of the ladder is d metres from the wall.

The top of the ladder is h metres above the ground.

The angle between the ladder and the ground is x° .

- (a) Some safety instructions say it is safe to climb the ladder when $h = 3.5d$.

Determine the value of x when $h = 3.5d$.

Answer [2]

- (b) Some different safety instructions say the angle between the ladder and the ground should be 70° . The ladder is then moved so that $x = 70^\circ$.

Without further calculations, how does this change in angle affect the height, h metres, of the top of the ladder above the ground?

.....
 [1]

10. The table shows pairs of values of x and y .

x	4	5
y	400	625

- (a) Which of the following statement is correct?

Statement A: $y \propto x$

Statement B: $y \propto x^2$

Statement C: $y \propto x^3$

Answer Statement [1]

- (b) Write a formula for y in terms of x .

Answer [2]

11. Simplify.

(a) $3 + p(3 - p)$

Answer [1]

(b) $9x^{-4} \div \frac{1}{2}x^6$

Answer [2]

12. Solve the inequalities $x - 3 < \frac{3}{2}x - 2 \leq \frac{x + 18}{6}$ and state the integer values of x that satisfy them.

Answer [3]

13. A bag contains 12 blue marbles and 8 red marbles.
- (a) A marble is chosen at random and then replaced.
What is the probability that it is a red marble?

Answer [1]

- (b) How many red marbles must be placed in the bag so that the probability of choosing a red marble would be $\frac{3}{5}$?

Answer [2]

14. Express as $\frac{3}{x-3} - \frac{4}{x^2-9}$ a single fraction in its simplest form.

Answer [3]

15. A train 180 m long passes through a tunnel.
The average speed of the train is 42 km/h.
- (a) Express 42 km/h in m/s.

Answer m/s [1]

- (b) The train passes through a 2.4 km tunnel.
Calculate the time for the train to completely pass through the tunnel.
Give your answer in minutes and seconds, to the nearest second.

Answer mins [2]

16. $ab^2 + c = \frac{2c + b}{a}$

Rearrange the formula to make c the subject.

Answer [3]

17. (a) Factorise completely $3ax + 12by - 9ay - 4bx$.

Answer [2]

(b) Show that $(3n + 5)^2 - 7$ is a multiple of 3 for all integer values of n .

Answer

[2]

18. The timings of 16 students running a 100 metre race is recorded below.

Time, x seconds	$12 \leq x < 13$	$13 \leq x < 14$	$14 \leq x < 15$	$15 \leq x < 16$
Frequency	3	5	6	2

- (a) Calculate an estimate for
 (i) the mean running time of the students,

Answer s [1]

- (ii) the standard deviation of the running time.

Answer s [2]

- (b) It was found that there was a mechanical error in the stopwatch used to time the run. An actual 10 seconds is measured as 9 seconds by the stopwatch. Explain how the mean will change after the adjustment.

.....

 [1]

19. Express as a product of prime factors, $168 = 2^3 \times 3 \times 7$ and $A = 2^p \times 3^3 \times 5$.

Using the above information, find

- (a) the smallest integers m and n such that $\frac{168 \times m}{\sqrt{n}}$ is a perfect square and $m > n$,

Answer $m =$

$n =$ [2]

- (b) the value of p and of A given that the highest common factor of 168 and A is 12.

Answer $p =$

$A =$ [2]

20.

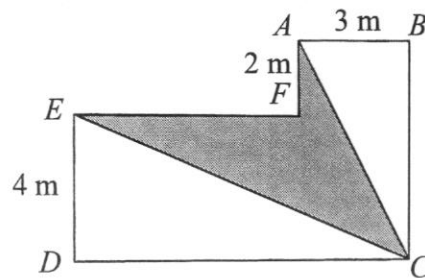

The diagram shows a shape $ABCDEF$.

All the corners of the shape are right angles.

$ED = 4$ m, $AF = 2$ m and $AB = 3$ m.

The perimeter of the shape is 38 m.

Find the area of the shaded part $ECAF$ of the diagram.

Answer m² [4]

21. The points P and Q have coordinates $(7, 2)$ and $(6, -3)$ respectively.

(a) Determine if the line $y + 5x = 4$ is parallel to PQ .

Answer

DANYAL
EDUCATION

DANYAL
EDUCATION

[2]

(b) (i) Find the column vector \vec{PQ} .

DANYAL
EDUCATION

Answer [1]

(ii) Find $|\vec{PQ}|$.

DANYAL
EDUCATION

DANYAL
EDUCATION

Answer [2]

22.

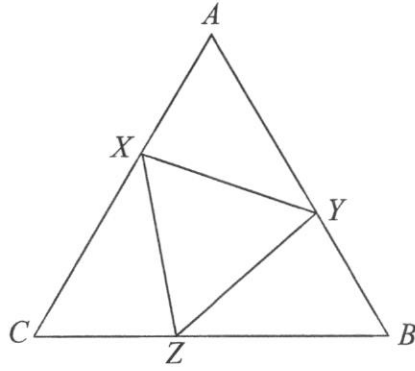

In the diagram, triangle ABC is an equilateral triangle.

X , Y and Z lie on lines AC , AB and BC respectively and $AX = CZ = BY$.

(a) Prove that triangle AXY is congruent to triangle CZX .

Answer

[3]

(b) Determine if triangle XYZ is an equilateral triangle.

Answer

[2]

23.

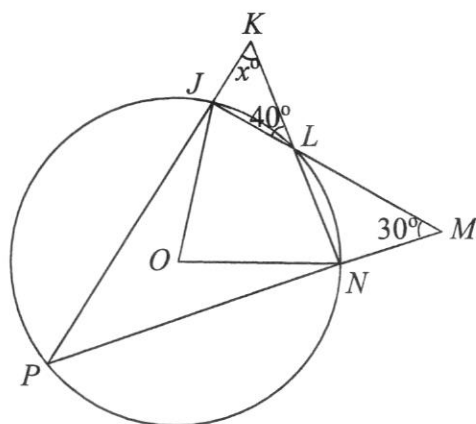

In the diagram, O is the centre of the circle. P, N, L and J lie on the circumference of the circle. The lines PJ and NL are extended to meet at K . The lines JL and PN are extended to meet at M . Angle JKL is 40° , angle LMN is 30° and angle JKL is x° .

Write down an expression, in terms of x , for

(a) (i) angle PJM ,

Answer [1]

(ii) angle PNL .

Answer [1]

(b) By considering triangle JMP , form an equation in x and solve it.

Answer $x =$ [2]

24.

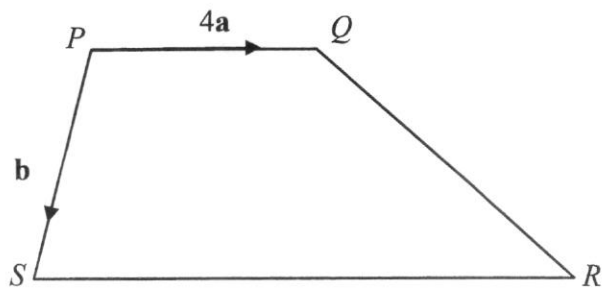

In the diagram, $PQRS$ is a trapezium where $\vec{PQ} = 4\mathbf{a}$ and $\vec{PS} = \mathbf{b}$.

A point T lies inside the trapezium where $QT : TS = 4 : 5$.

SR is twice the length of PQ .

(a) Express, as simply as possible, in terms of \mathbf{a} and/or \mathbf{b} ,

(i) \vec{QS} ,

Answer [1]

(ii) \vec{QT} ,

Answer [1]

(b) Determine whether P , T and R lie on the same straight line.

Answer

[3]

25.

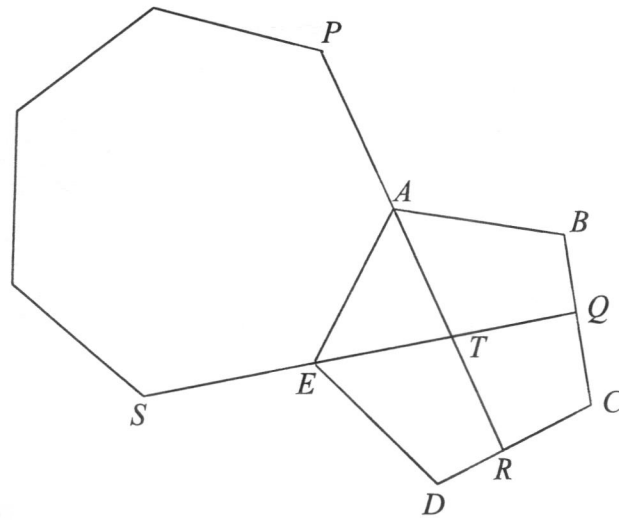

In the diagram, a regular heptagon and regular pentagon are fitted together at the edge AE .

PAR and SEQ are straight lines.

Find angle TRD .

Answer [5]

26. The table below shows the distribution of three types of apartments in three blocks of flats.

	3-room	4-room	5-room
Block 1	10	20	50
Block 2	25	45	10
Block 3	30	50	20

The information can be represented by the matrix $T = \begin{pmatrix} 10 & 20 & 50 \\ 25 & 45 & 10 \\ 30 & 50 & 20 \end{pmatrix}$.

The floor areas of the 3-room, 4-room and 5-room apartments are 60 m², 90 m² and 110 m²

respectively and this information can be represented by the matrix $A = \begin{pmatrix} 60 \\ 90 \\ 110 \end{pmatrix}$

(a) Evaluate TA .

Answer [2]

(b) Explain what the elements in TA represent.

.....
 [1]

(c) Maintenance fees are charged based on the floor area of the apartments in the three blocks of flats. The maintenance fee rates (\$/m²) for Block 1, 2 and 3 are \$3, \$4, and \$6 respectively. Write down a 1×3 matrix C to show the maintenance fee rates for the three blocks of flats.

Answer [1]

- (d) Hence, using matrix multiplication, find the total estate management fee for these three blocks of flats.

Answer [2]

27. (a) The first four terms of a sequence are 5, 9, 13 and 17.

The sum of the first n terms of this sequence is given by $an^2 + bn$.

- (i) When $n = 1$, $a + b = 5$.

Show that $4a + 2b = 14$.

Answer

- (ii) Solve $a + b = 5$

$$4a + 2b = 14.$$

[1]

Answer $a =$

$b =$ [2]

(b) The n th term of another sequence is $n^2 + 4$.

Anthony says,

“The n th term of the sequence is always a prime number when n is an odd number.”

Anthony is wrong.

Give an example to show that Anthony is wrong.

Answer [2]

~ End of Paper ~

Candidate Name: _____ Index No: _____ Class: _____

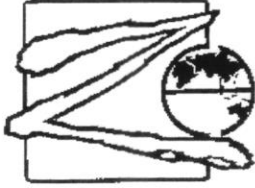

**ZHENGHUA SECONDARY SCHOOL
PRELIMINARY EXAMINATIONS 2023
FOUR EXPRESS
FOUR NORMAL (ACADEMIC) (O LEVEL)
MATHEMATICS
Paper 2**

4052/02

23 AUGUST 2023

Candidates answer on the Question Paper.

2 hours 15 min

*Zhenghua Secondary School Zhenghua Secondary School Zhenghua Secondary School Zhenghua Secondary School
Zhenghua Secondary School Zhenghua Secondary School Zhenghua Secondary School Zhenghua Secondary School
Zhenghua Secondary School Zhenghua Secondary School Zhenghua Secondary School Zhenghua Secondary School
Zhenghua Secondary School Zhenghua Secondary School Zhenghua Secondary School Zhenghua Secondary School
Zhenghua Secondary School Zhenghua Secondary School Zhenghua Secondary School Zhenghua Secondary School*

READ THESE INSTRUCTIONS FIRST

Write your index number and name on all the work you hand in.

Write in dark blue or black pen.

You may use an HB pencil for any diagrams or graphs.

Do not use staples, paper clips, glue or correction fluid.

Answer **all** questions.

The number of marks is given in brackets [] at the end of each question or part question.

If working is needed for any question it must be shown with the answer.

Omission of essential working will result in loss of marks.

The total of the marks for this paper is 90.

The use of an approved scientific calculator is expected, where appropriate.

If the degree of accuracy is not specified in the question, and if the answer is not exact, give the answer to three significant figures. Give answers in degrees to one decimal place.

For π , use either your calculator value or 3.142.

Name of Setter:

This document consists of 22 printed pages.

[Turn over]

Mathematical Formulae*Compound interest*

$$\text{Total amount} = P \left(1 + \frac{r}{100} \right)^n$$

Mensuration

$$\text{Curved surface area of a cone} = \pi r l$$

$$\text{Surface area of a sphere} = 4\pi r^2$$

$$\text{Volume of a cone} = \frac{1}{3} \pi r^2 h$$

$$\text{Volume of a sphere} = \frac{4}{3} \pi r^3$$

$$\text{Area of triangle } ABC = \frac{1}{2} ab \sin C$$

$$\text{Arc length} = r\theta, \text{ where } \theta \text{ is in radians}$$

$$\text{Sector area} = \frac{1}{2} r^2 \theta, \text{ where } \theta \text{ is in radians}$$

Trigonometry

$$\frac{a}{\sin A} = \frac{b}{\sin B} = \frac{c}{\sin C}$$

$$a^2 = b^2 + c^2 - 2bc \cos A$$

Statistics

$$\text{Mean} = \frac{\sum fx}{\sum f}$$

$$\text{Standard deviation} = \sqrt{\frac{\sum fx^2}{\sum f} - \left(\frac{\sum fx}{\sum f} \right)^2}$$

1 (a) Solve $\frac{1}{x-1} + \frac{2}{x-2} = \frac{3}{x-3}$.

Answer $x = \dots\dots\dots$ [2]

(b) Simplify $(a^2b)^{\frac{1}{2}} \times (ab^{-3})^{\frac{1}{3}}$.

Answer $\dots\dots\dots$ [1]

(c) (i) Express $x^2 + 11x - 15$ in the form $(x+a)^2 + b$.

Answer $\dots\dots\dots$ [1]

(ii) Hence solve the equation $x^2 + 11x - 15 = 0$, giving your answers correct to two decimal places.

Answer $x = \dots\dots\dots$ or $\dots\dots\dots$ [3]

(d) Simplify $\frac{3a^2 + 12a - 36}{ab - 2b + a^2 - 2a}$.

Answer [3]

2 (a) Abigale has two possible options to invest a sum of money for 3 years.

Account A pays compound interest 6%, 8% and 10% for the 3 years respectively.
Account B pays compound interest 10%, 8% and 6% for the 3 years respectively.

Explain which, if any, is a better choice for Abigale's investment.

.....
.....
..... [1]

(b) An amount of \$3750 was placed in an account that pays simple interest.

After 3 years, the balance was \$4620.

(i) Find the rate of interest.

Answer% [2]

(ii) If the same interest is paid using compound interest, calculate the balance in the account after the same time period.

Answer \$..... [2]

- (c) On 1 June 2022, Ben changed S\$6200 into American dollars.
The exchange rate between American dollars (US\$) and Singapore dollars (S\$) was
 $\text{US\$1} = \text{S\$1.37}$.
- (i) Calculate the amount of American dollars he would receive.

Answer US\$..... [2]

- (ii) On a trip to the USA, Ben bought a tablet for US\$1899 from a departmental store.
When Ben bought the tablet, the store made a profit of 8%.
Calculate how much the store paid for the tablet.

Answer US\$..... [2]

- 3 The cumulative frequency graph below shows speeds in km/h of cyclists passing a certain point during a race.

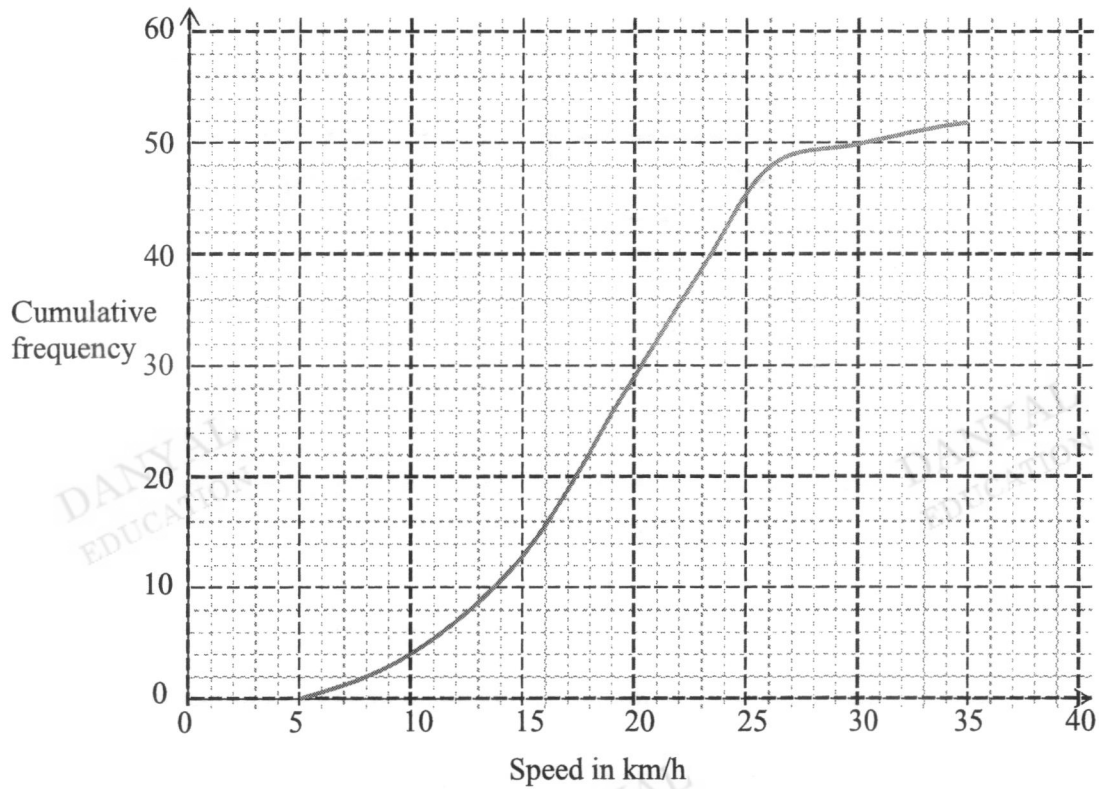

(a) Use the curve to estimate

- (i) the median speed of the cyclists,

Answer km/h [1]

- (ii) the percentage of cyclists having speed more than 21 km/h.

Answer % [1]

- (iii) the ninety-sixth percentile.

Answer km/h [1]

- (iv) Complete the grouped frequency table of the speeds of the cyclists passing a certain point during the race.

Speed (x km/h)	$5 \leq x < 10$	$10 \leq x < 15$	$15 \leq x < 20$	$20 \leq x < 25$	$25 \leq x < 30$	$30 \leq x < 35$
Frequency	4					

[2]

- (b) In the previous year, the same race had taken place.
The box-and-whisker plot shows the distribution of the speed of the cyclists.

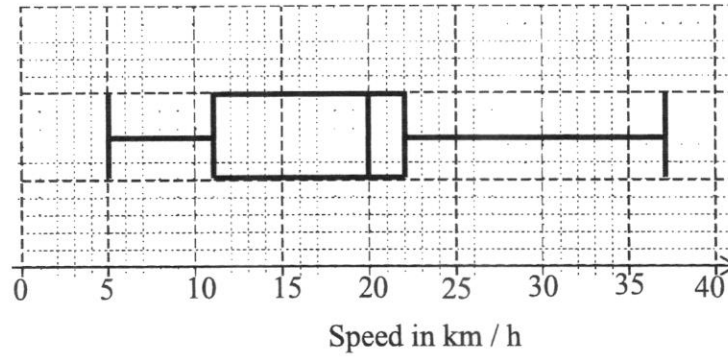

Make two comparisons between the performances of the cyclists in the two years.
Use figures to support your answer.

.....

.....

.....

..... [3]

DANYAL
EDUCATION

DANYAL
EDUCATION

4 The variables x and y are connected by the equation

$$y = \frac{x^2}{5} + \frac{6}{x}$$

The table below shows some values of x and the corresponding values of y correct to 1 decimal place.

(a) Complete the table.

x	1	1.5	2	3	4	5	6
y	6.2	4.5	3.8	3.8	4.7	6.2	

[1]

(b) On the grid at the **next page**, draw the graph of $y = \frac{x^2}{5} + \frac{6}{x}$ for $1 \leq x \leq 6$.

[3]

(c) Use your graph to find the value(s) of x in the range of $1 \leq x \leq 6$ for which

$$\frac{x^2}{5} + \frac{6}{x} - 4 = 0.$$

Answer $x = \dots\dots\dots$ [2]

(d) By drawing a tangent, find the gradient of the curve at point $(4, 4.7)$.

Answer $\dots\dots\dots$ [2]

(e) By drawing the graph $y = \frac{1}{2}x + 4$ on the grid, find the equation in the form

$2x^3 + ax^2 + bx + c = 0$, which is satisfied by the x -coordinates of the points at which the two graphs intersect.

Answer $\dots\dots\dots$ [4]

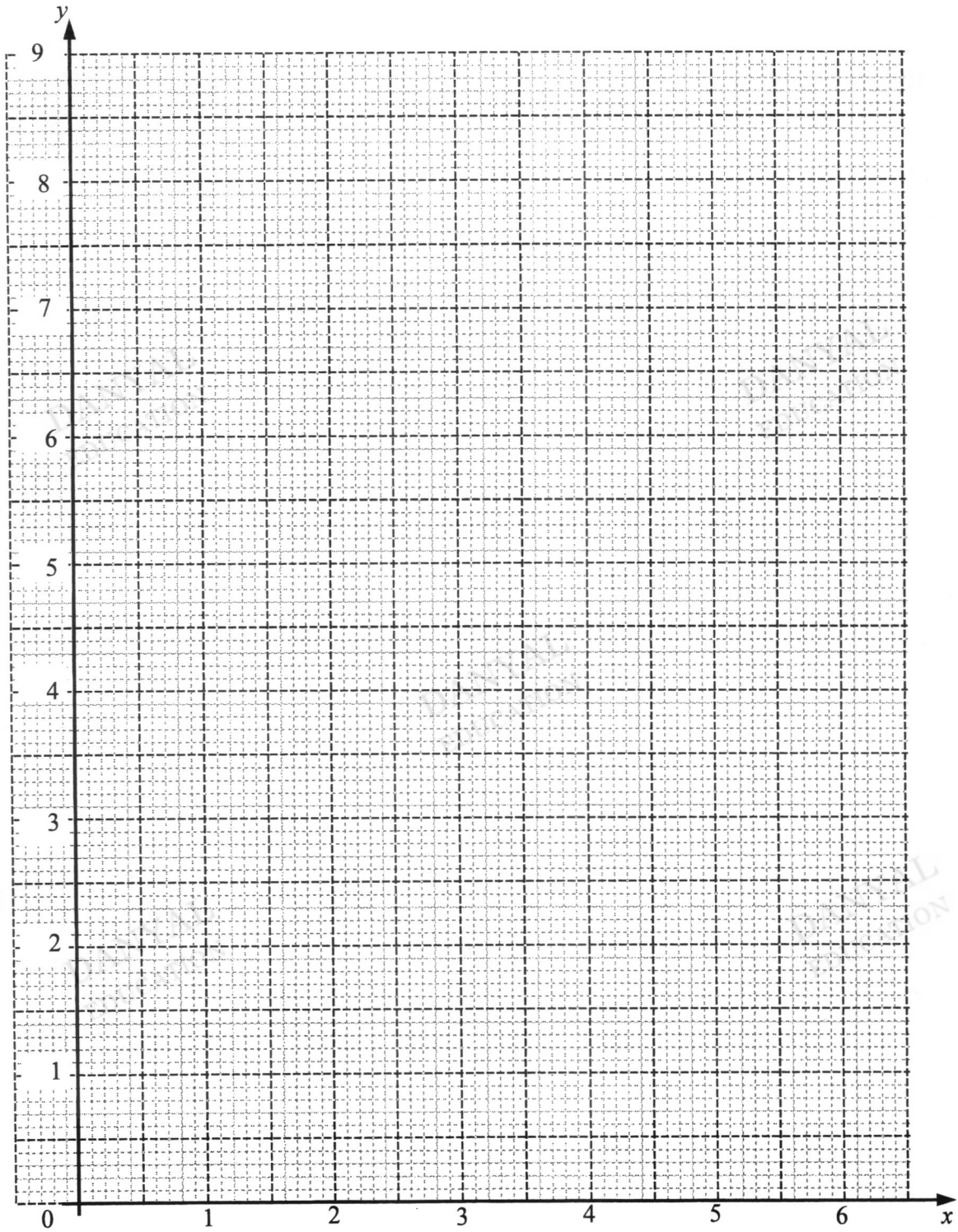

- 5 The diagram below shows a solid cube $ABCDEFGH$.

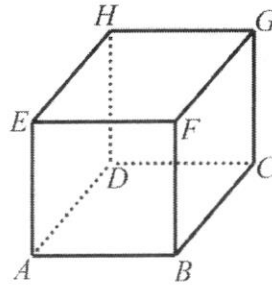

- (a) The solid cube was produced after recasting a solid spherical toy with diameter 10 cm. Show that the length of a side of the cube is approximately 8.06 cm.

DANYAL
EDUCATION

DANYAL
EDUCATION

Answer shown cm [2]

- (b) An ant is crawling from the point A . Find the shortest distance that it can take from point A to point G .

DANYAL
EDUCATION

DANYAL
EDUCATION

Answer cm [2]

- (c) The solid cube is placed inside an open cylindrical container which has base radius 6 cm and height 13 cm.

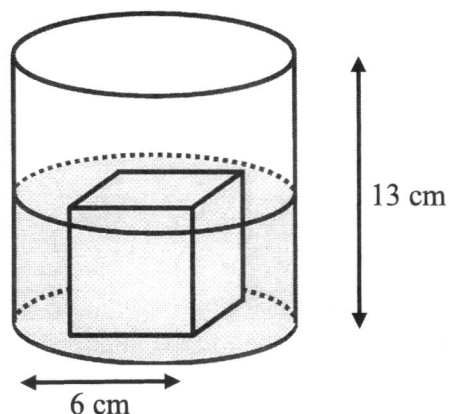

V cm³ of water is poured into the container at a rate of 2.5 cm³/s until it covers the cube as shown in the diagram above.

- (i) Calculate the amount of time, in seconds, it takes for all the water to be poured in.

Answer s [4]

- (ii) When the cube is removed from the container, the water level drops by x cm. Assuming that the water loss is negligible upon the removal of the cube, calculate the value of x .

Answer cm [2]

- 6 In the diagram, A, B, C and D are points on the circle with centre O .
 The lines AC and BD intersect at E .
 The tangent to the circle at C meets AD produced at T .
 $\angle ACB = 66^\circ$, $\angle CAD = 36^\circ$ and $AC = 10$ cm.

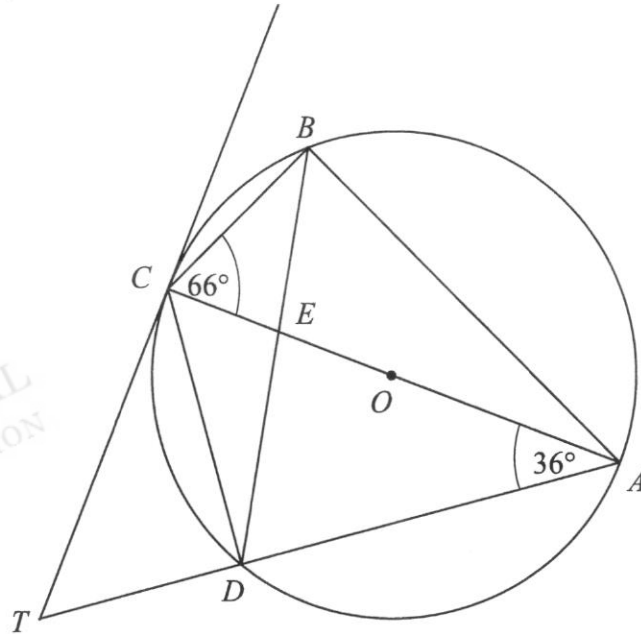

- (a) Find the angle DCT .

Answer [2]

- (b) Show that the triangles BCE and ADE are similar.
 Give a reason for each statement you make.

.....

.....

.....

.....

..... [2]

(c) Calculate DE .

DANYAL
EDUCATION

DANYAL
EDUCATION

Answer cm [4]

(d) Calculate the length of the minor arc BC .

DANYAL
EDUCATION

DANYAL
EDUCATION

DANYAL
EDUCATION

Answer cm [3]

- 7 A city tour starting at Hotel A is planned. The coach travels 43 km in the **north-west** direction to B , the zoo, where it stops for 3 hours. After the visit to the zoo, the coach continues its journey to a popular seafood restaurant at C , 18 km away, for lunch. After lunch, the coach brings the tourists to visit a museum at D , 24 km away and $\angle CDA = 85^\circ$.

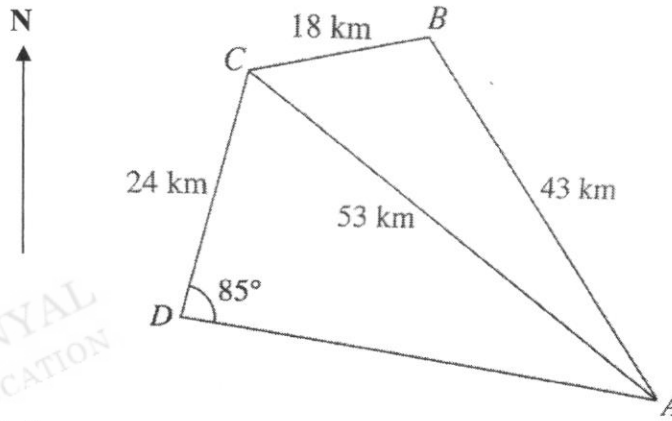

- (a) Find
(i) $\angle BAC$,

- (ii) $\angle CAD$.

Answer [2]

Answer [2]

(b) Find the bearing of C from A .

Answer [2]

(c) Calculate the shortest distance from D to AC .

Answer km [3]

- 8 (a) $\xi = \{\text{integers } x: 0 < x < 12\}$
 $P = \{\text{even numbers}\}$
 $Q = \{\text{prime numbers}\}$

(i) List the elements in P .

Answer [1]

(ii) List the elements in $(P \cup Q)'$.

Answer [1]

(iii) Complete the Venn diagram showing all the elements of ξ .

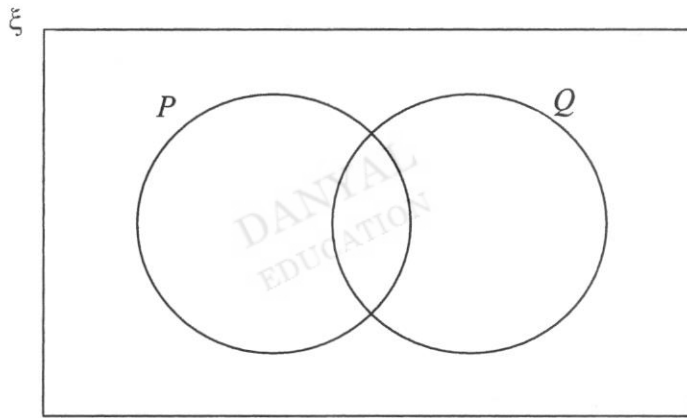

[1]

(iv) Find the value of

(a) $n[(P \cap Q) \cup Q']$

Answer [1]

(b) $n[(P \cup Q) \cap (P \cap Q)']$

Answer [1]

- (b) The table shows the number of cars owned by each of 25 families.

1	3	0	2	1
3	1	6	0	1
4	2	1	3	2
0	1	3	2	4
2	0	2	1	3

- (i) A family is chosen at random.
Find the probability that it owns 3 cars.

Answer [1]

- (ii) Two families are chosen at random.
Find the probability that one family owns 2 cars and the other own 3 cars.

Answer [2]

- (iii) A car is chosen at random.
Find the probability that it belongs to a family which owns 2 cars.

Answer [2]

- 9 Air-conditioners are designed to control both the air temperature and humidity. Choosing the right cooling capacity for your air-conditioner is important for proper comfort and energy optimisation.

An oversized air-conditioning system is costly and may cost more to operate. It might also not properly dehumidify the space. This is because the air-conditioner cools the space too quickly and then powers down before the moisture level is reduced. On the other hand, an undersized air-conditioning system will not provide adequate cooling and dehumidification.

To properly size your air conditioning system, a useful rule of thumb is as follows:

Cooling capacity required in kW* = Total aircon floor area (m²) ÷ 5
to convert to Btu/hr, multiply the cooling capacity figure in kW by 3,412

Mr Wong has recently purchased an apartment and would like to instal air-conditioning units to the Main-bedroom, Bedroom, and the Living room. (Refer to page 21 for the floor plan)

- (a) Find the total floor area of the rooms to be air-conditioned in m².

Answer m² [2]

- (b) Calculate the required Btu/hr for each of the rooms.

Answer Main Bedroom Bedroom Living room [1]

(c) Mr Wong's family use the air-conditioning in their bedrooms from 7pm to 6am and the living room from 5pm to 10pm daily. On Saturday and Sundays, Mr Wong will use the living room air-conditioning for an extra 3 hours before 5pm.

(i) Determine with explanation which of the packages is suitable for Mr Wong.
(Refer to page 22)

Answer Package because [1]

(ii) Calculate the cost of electricity usage (inclusive of GST 8%) by Mr Wong's family for air-conditioning for the month of July 2023.

Answer \$..... [7]

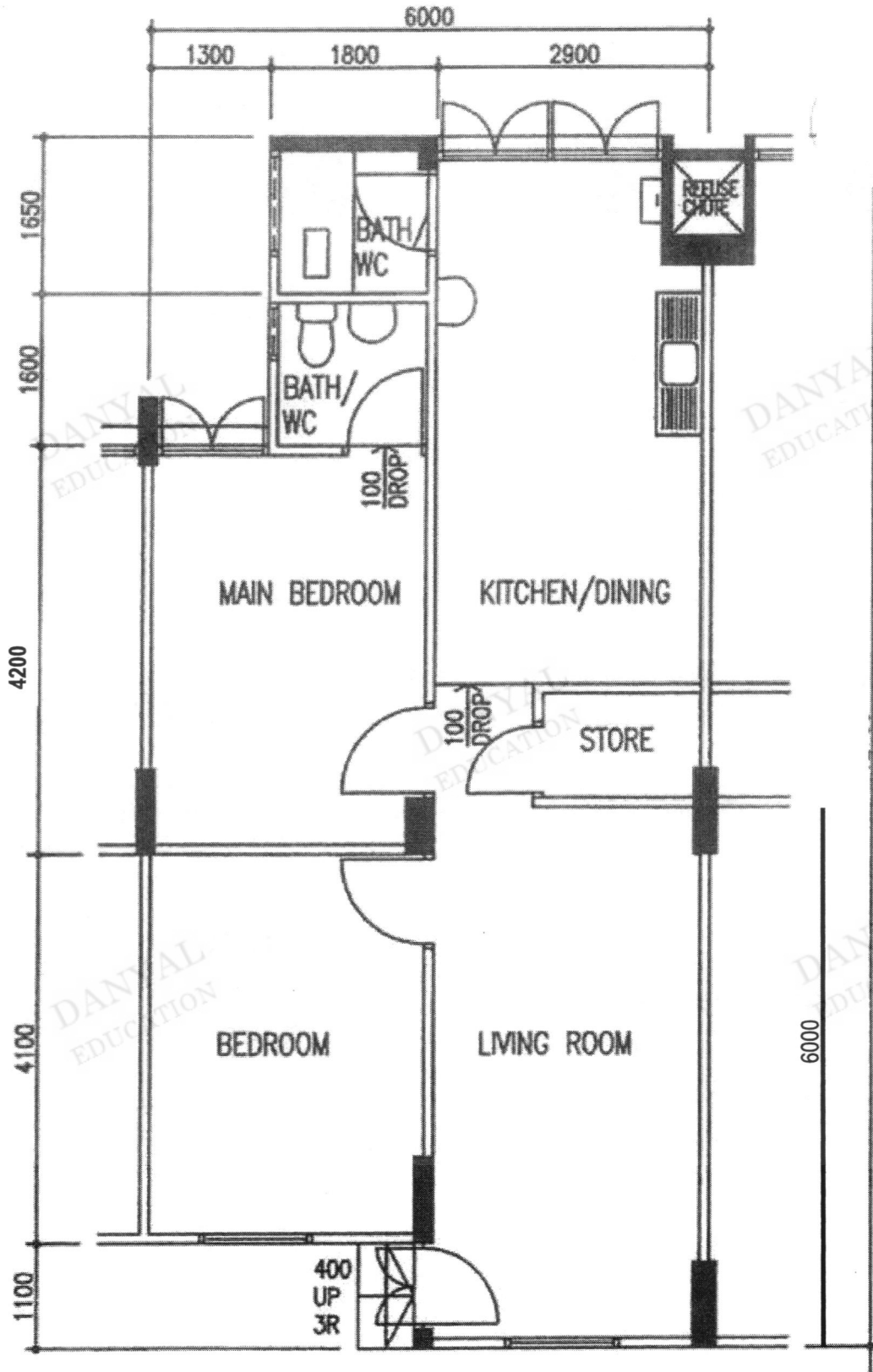

Floorplan of apartment. All measurements are measured in mm.

Package A	Package B	Package C	Package D
<p>MIDEA INVERTER SYSTEM 3 AIRCON MAE-3M21D / MSEID-09 X 1 + MSEID-12 X 2 (4 TICKS) INSTALLATION INCLUDED</p> <p>S\$3,199.00 S\$3,399.00 (save 5%)</p> <p>☆☆☆☆☆</p> <p>ADD TO CART</p> <p>♡ Add to Wish List</p>	<p>MIDEA INVERTER SYSTEM 3 AIRCON MAE-3M21D / MSEID-09 X 2 + MSEID-12 X 1 (4 TICKS) INSTALLATION INCLUDED</p> <p>S\$3,149.00 S\$3,349.00 (save 5%)</p> <p>☆☆☆☆☆</p> <p>ADD TO CART</p> <p>♡ Add to Wish List</p>	<p>MIDEA INVERTER SYSTEM 3 AIRCON MAE-3M21D / MSEID-09 X 3 (4 TICKS) INSTALLATION INCLUDED</p> <p>S\$3,099.00 S\$3,299.00 (save 6%)</p> <p>☆☆☆☆☆</p> <p>ADD TO CART</p> <p>♡ Add to Wish List</p>	<p>MIDEA INVERTER SYSTEM 3 AIRCON MAE-3M21D / MSEID-12 X 3 (4 TICKS) INSTALLATION INCLUDED</p> <p>S\$3,249.00 S\$3,449.00 (save 5%)</p> <p>☆☆☆☆☆</p> <p>ADD TO CART</p> <p>♡ Add to Wish List</p>

Power consumption	9000 btu/hr unit	12000 btu/hr	Outdoor unit
	20W	24W	1420W

$$\text{Electricity Consumption (kWh)} = \text{Power consumption(kW)} \times \text{time (hours)}$$

1kW = 1000W

29.96 cents/kWh

27.74 cents/kWh (w/o GST)
ELECTRICITY TARIFF
[wef 1 Jul - 30 Sep 23]

July 2023

Sunday	Monday	Tuesday	Wednesday	Thursday	Friday	Saturday
						1
2	3	4	5	6	7	8
9	10	11	12	13	14	15
16	17	18	19	20	21	22
23	24	25	26	27	28	29
30	31					

DANYAL
EDUCATION

DANYAL
EDUCATION

DANYAL
EDUCATION

DANYAL
EDUCATION

DANYAL
EDUCATION

DANYAL
EDUCATION

DANYAL
EDUCATION

Marking Scheme

DANYAL
EDUCATION

DANYAL
EDUCATION

Marking Scheme

1. Calculate $\frac{\sqrt[3]{4\pi^2 - 15^2}}{0.63}$.

Leave your answer to 4 decimal places.

Answer -9.0530 [1]

2. Factorise $9x^2 + 12x - 12$.

Answer $3(3x-2)(x+2)$ [2]

3. The sine of an angle is 0.427.
Give two possible values for the angle.

$\sin^{-1} 0.427$

Answer 25.3^o or 154.7^o [2]

4. 8 students took a test and their marks were recorded as follows.

8 10 9 13 10 9 x y

The modal score for the 8 students is 10 and the median is 9.5.

If the range of the scores is 5, and $x \leq y$, determine the values of x and y .

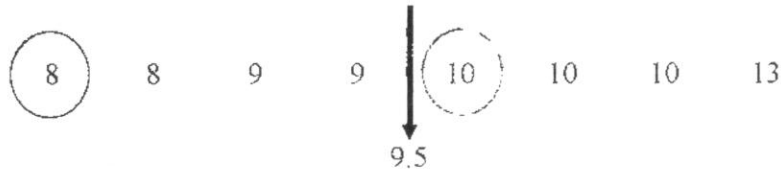

Answer $x = \dots\dots\dots 8$

$y = \dots\dots\dots 10$ [2]

5. A sum of money was shared among Allan, Ben and Chloe.

Allan receives $\frac{2}{5}$ of the money and the rest was shared among Ben and Chloe in the ratio 3:2.

Find the ratio of the money received in terms of Allan's : Ben's : Chloe's.

$$\text{Ben} = \frac{3}{5} \times \frac{3}{5} = \frac{9}{25}$$

$$\text{Charlie} = \frac{2}{5} \times \frac{3}{5} = \frac{6}{25}$$

M1 for either

Answer $\dots\dots\dots 10 \dots\dots\dots 9 \dots\dots\dots 6$ [2]

6. John is making two rectangular flower beds.

The dimensions of the larger rectangle will be four times the dimensions of the smaller rectangle.

There is going to be the same depth of soil in each flower bed.

John needs 120 kg of soil for the larger flower bed.

Work out how much soil John needs for the smaller flower bed.

$$\text{Area ratio} = 1 : 16$$

M1 for correct ratio identified

$$\text{Soil needed} = \frac{1}{16} \times 120$$

Answer 7.5 kg [2]

7. $T = \sqrt{\frac{w}{d^3}}$ for a particular value of w and d .

If w is increased by 20%, and d is decreased by 10%, determine the percentage change in T .

$$\text{New } w = 1.2w$$

$$\text{New } d = 0.9d$$

$$\text{New } T = \sqrt{\frac{1.2w}{(0.9d)^3}}$$

M1

$$= 1.28300 \sqrt{\frac{w}{d^3}}$$

(change from 1 to 1.28300 which is 28.3% change)

Answer 28.3 % [2]

8. Jamie is using the quadratic formula to solve a quadratic equation. She substitutes values into the formula and correctly gets

$$x = \frac{-9 \pm \sqrt{81 - 48}}{6}$$

Find the quadratic equation that Jamie is solving, giving your answer in the form $ax^2 + bx + c = 0$, where a , b and c are integers.

$$-b = -9 \Rightarrow b = 9$$

$$2a = 6 \Rightarrow a = 3$$

$$-4(3)c = -48 \Rightarrow c = 4$$

M1 for any 1 correct

Answer $3x^2 + 9x + 4 = 0$ [2]

9.

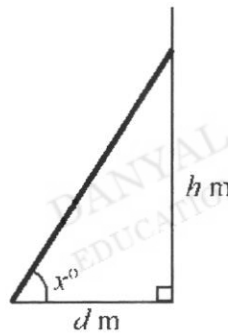

A ladder is leaning against a vertical wall as shown in the diagram.

The bottom of the ladder is d metres from the wall.

The top of the ladder is h metres above the ground.

The angle between the ladder and the ground is x° .

- (b) Some safety instructions say it is safe to climb the ladder when $h = 3.5d$.

Determine the value of x when $h = 3.5d$.

$$\tan x = \frac{3.5d}{d}$$

$$x = \tan^{-1} 3.5$$

M1 ($x = 74.0546041\dots$)

Answer 74.1 [2]

- (b) Some different safety instructions say the angle between the ladder and the ground should be 70° . The ladder is then moved so that $x = 70^\circ$.

Without further calculations, how does this change in angle affect the height, h metres, of the top of the ladder above the ground?

The height will decrease

..... [1]

10. The table shows pairs of values of x and y .

x	4	5
y	400	625

- (a) Which of the following statement is correct?

Statement A: $y \propto x$

Statement B: $y \propto x^2$

Statement C: $y \propto x^3$

A: $\frac{400}{4} \neq \frac{625}{5} \Rightarrow y \neq kx$

B: $\frac{400}{4^2} = \frac{625}{5^2} \Rightarrow y = kx^2$

C: $\frac{400}{4^3} \neq \frac{625}{5^3} \Rightarrow y \neq kx^3$

Answer Statement **B** [1]

- (b) Write a formula for y in terms of x .

$k = 25$ (from part (a)) M1 (or B1) for 25

Answer $y = 25x^2$ [2]

11. Simplify.

(a) $3 + p(3 - p)$

Answer $-p^2 + 3p + 3$ [1]

(b) $9x^4 \div \frac{1}{2}x^6$

$$\frac{9}{x^4} \times \frac{2}{x^6}$$

M1 (for $\frac{9}{x^4}$)

Answer $\frac{18}{x^{10}}$ [2]

12. Solve the inequalities $x - 3 < \frac{3}{2}x - 2 \leq \frac{x + 18}{6}$ and state the integer values of x that satisfy them.

$$x - 3 < \frac{3}{2}x - 2$$

$$2x - 6 < 3x - 4$$

$$-2 < x$$

$$x > -2$$

$$-2 < x \leq \frac{15}{4}$$

$$\frac{3}{2}x - 2 \leq \frac{x + 18}{6}$$

$$9x - 12 \leq x + 18$$

$$8x \leq 30$$

$$x \leq \frac{15}{4} \text{ or } \left(x \leq 3\frac{3}{4} \right)$$

Answer $-1, 0, 1, 2, 3$ [3]

13. A bag contains 12 blue marbles and 8 red marbles.

(a) A marble is chosen at random and then replaced.

What is the probability that it is a red marble?

Answer $\frac{2}{5}$ Or 0.4 [1]

(b) How many red marbles must be placed in the bag so that the probability of choosing a red marble would be $\frac{3}{5}$?

$$\frac{8+x}{20+x} = \frac{3}{5} \quad \text{M1}$$

$$40+5x = 60+3x$$

$$x = 10$$

Answer 10 [2]

14. Express as $\frac{3}{x-3} - \frac{4}{x^2-9}$ a single fraction in its simplest form.

$$\frac{3(x+3)}{(x+3)(x-3)} - \frac{4}{(x+3)(x-3)} \quad \text{M1 factorise into } (x+3)(x-3)$$

$$= \frac{3x+9-4}{(x+3)(x-3)} \quad \text{M1}$$

Answer $\frac{3x+5}{(x+3)(x-3)}$ [3]

15. A train 180 m long passes through a tunnel.
The average speed of the train is 42 km/h.
- (a) Express 42 km/h in m/s.

$$\frac{42}{1} \times \frac{1000}{60 \times 60}$$

Answer 11.7 accept 11.67 m/s [1]

- (b) The train passes through a 2.4 km tunnel.
Calculate the time for the train to completely pass through the tunnel.
Give your answer in minutes and seconds, to the nearest second.

$$\begin{aligned} & \frac{2400+180}{11.666667} && \text{M1 (for } (2400 + 180)/\text{their (a))} \\ & = 221.142857... \text{ sec} \\ & = 3.685714... \text{ min} \\ & = 3 \text{ min } 41.14 \text{ sec} \end{aligned}$$

Answer 3 min 41 sec [2]

16. $ab^2 + c = \frac{2c+b}{a}$

Rearrange the formula to make c the subject.

$$a^2b^2 + ac = 2c + b \quad \text{M1 no fraction}$$

$$ac - 2c = b - a^2b^2$$

$$c(a - 2) = b - a^2b^2 \quad \text{M1 factorise}$$

$$\text{Answer } \dots\dots\dots c = \frac{b - a^2b^2}{a - 2} \dots\dots\dots [3]$$

17. (a) Factorise completely $3ax + 12by - 9ay - 4bx$.

$$\begin{aligned} & 3ax - 9ay + 12by - 4bx \\ &= 3a(x - 3y) + 4b(3y - x) \quad \text{M1 identifying } 3a \text{ and } 4b \\ &= 3a(x - 3y) - 4b(x - 3y) \end{aligned}$$

$$\text{Answer } \frac{(3a - 4b)(x - 3y)}{(4b - 3a)(3y - x)} \quad [2]$$

- (b) Show that $(3n + 5)^2 - 7$ is a multiple of 3 for all integer values of n .

Answer

$$\begin{aligned} & 9n^2 + 30n + 25 - 7 \\ &= 9n^2 + 30n + 18 \\ &= 3 \times (3n^2 + 10n + 6) \end{aligned}$$

Hence, $(3n + 5)^2 - 7$ is a multiple of 3 for all integer values of n .

[2]

18. The timings of 16 students running a 100 metre race is recorded below.

Time (x sec)	$12 \leq x < 13$	$13 \leq x < 14$	$14 \leq x < 15$	$15 \leq x < 16$
Frequency	3	5	6	2

- (a) Calculate an estimate for
(i) the mean running time of the students,

$$\text{Answer } 13.9375 \quad \text{accept } 13.9 \quad \text{sec} \quad [1]$$

- (ii) the standard deviation of the running time.
0.93 – no marks

$$\text{Answer } 0.933 \quad \text{sec} \quad [2]$$

- (b) It was found that there was a mechanical error in the stopwatch used to time the run. An actual 10 seconds is measured as 9 seconds by the stopwatch.

Explain how the mean will change after the adjustment.

The mean time of the runners will drop.....

(Do not accept if students go on to say drop by 10 seconds).....

.....

..... [1]

28. Express as a product of prime factors, $168 = 2^3 \times 3 \times 7$ and $A = 2^p \times 3^3 \times 5$.

Using the above information, find

- (a) the smallest integers m and n such that $\frac{168 \times m}{\sqrt{n}}$ is a perfect square and $m > n$,

Answer $m = \dots 21 \dots$

$n = \dots 4 \dots$ [2]

- (b) the value of p and of A given that the highest common factor of 168 and A is 12.

Answer $p = \dots 2 \dots$

$A = \dots 540 \dots$ [2]

19.

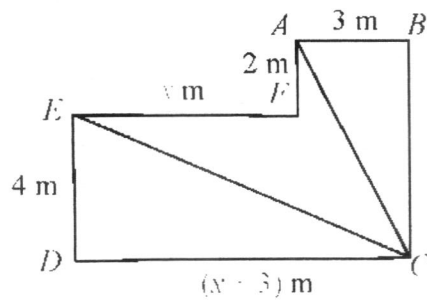

The diagram shows a shape $ABCDEF$.

All the corners of the shape are right angles.

$ED = 4$ m, $AF = 2$ m and $AB = 3$ m.

The perimeter of the shape is 38 m.

Find the area of the shaded part $ECAF$ of the diagram.

$$3 + 6 + (x + 3) + 4 + x + 2 = 38$$

$$x = 10$$

$$\text{Area} = \frac{1}{2}(10)(4) + \frac{1}{2}(2)(3)$$

Answer 23 m² [4]

20. The points P and Q have coordinates $(7, 2)$ and $(6, -3)$ respectively.

(a) Determine if the line $y + 5x = 4$ is parallel to PQ .

Answer

$$\begin{aligned} \text{Gradient } PQ &= \frac{2 - (-3)}{7 - 6} \\ &= 5 \neq -5 \text{ (gradient of line)} \end{aligned}$$

Line is **not** parallel to PQ

[2]

(b) (i) Find the column vector \vec{PQ} .

$$\begin{pmatrix} 6 \\ -3 \end{pmatrix} - \begin{pmatrix} 7 \\ 2 \end{pmatrix}$$

Answer $\begin{pmatrix} -1 \\ -5 \end{pmatrix}$ [1]

(ii) Find $|\vec{PQ}|$.

$$\sqrt{(-1)^2 + (-5)^2}$$

Answer 5.10 [2]

21.

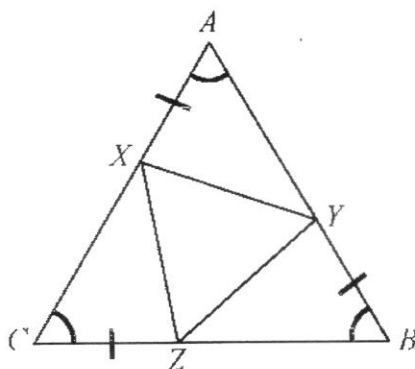

In the diagram, triangle ABC is an equilateral triangle.

X , Y and Z lie on lines AC , AB and BC respectively and $AX = CZ = BY$.

(a) Prove that triangle AXY is congruent to triangle CZX .

Answer

Angle $XAY =$ Angle ZCX (equilateral triangle ABC)

$AX = CZ$ (given)

$AY = AB - YB$

$CX = AC - AX$

Since $AB = AC$ and $AX = YB$ (given),

$CX = AY$

$\triangle AXY \equiv \triangle CZX$ (SAS)

[3]

(b) Determine if triangle XYZ is an equilateral triangle.

Answer

$BZ = BC - CZ = AC - AX = CX$

$\triangle AXY \equiv \triangle CZX \equiv \triangle BYZ$ (SAS)

$\therefore XY = XZ = YZ$

$\therefore \triangle XYZ$ is equilateral

Or using angles (sum of angles in triangle)

[2]

22.

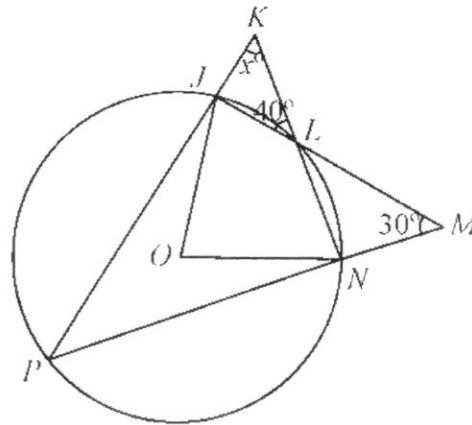

In the diagram, O is the centre of the circle. P , N , L and J lie on the circumference of the circle. The lines PJ and NI are extended to meet at K . The lines JL and PN are extended to meet at M . Angle JLK is 40° , angle LMN is 30° and angle JKI is x° .

Write down an expression, in terms of x , for

(a) (i) angle PJM ,

Answer $x + 40$ [1]

(ii) angle PNI ,

Answer $140 - x$ [1]

(b) By considering triangle JMP , form an equation in x and solve it.

$$(x + 40) + 30 + 40 = 180 \quad \text{M1 (angles } PJM + JMP + MPJ)$$

Answer $x =$ 70 [2]

23.

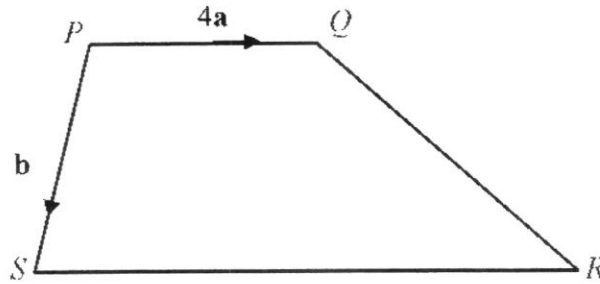

In the diagram, $PQRS$ is a trapezium where $\vec{PQ} = 4\mathbf{a}$ and $\vec{PS} = \mathbf{b}$.

A point T lies inside the trapezium where $QT : TS = 4 : 5$.

SR is twice the length of PQ .

No marks for wrong vector representation

(a) Express, as simply as possible, in terms of \mathbf{a} and/or \mathbf{b} ,

(i) \vec{QS} ,

$\mathbf{b} - 4\mathbf{a}$
Answer [1]

(ii) \vec{QT} ,

$\frac{4}{9}(\mathbf{b} - 4\mathbf{a})$
Answer [1]

(b) Determine whether P , T and R lie on the same straight line.

Answer

$$\vec{PR} = 8\mathbf{a} + \mathbf{b}$$

$$\vec{TR} = \frac{5}{9}\mathbf{b} + \frac{52}{9}\mathbf{a}$$

$$\vec{PT} = 4\mathbf{a} + \frac{4}{9}(\mathbf{b} - 4\mathbf{a})$$

$$\vec{PT} = \frac{20}{9}\mathbf{a} + \frac{4}{9}\mathbf{b}$$

$$\vec{PT} = \frac{4}{9}(5\mathbf{a} + \mathbf{b}) \neq k\vec{PR}$$

Therefore, P , T and R do **not** lie on the same straight line

[3]

24.

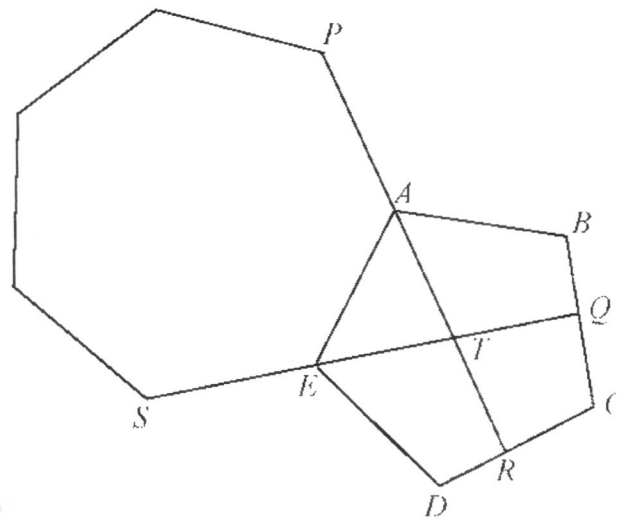

In the diagram, a regular heptagon and regular pentagon are fitted together at the edge AE .
 PAR and SEQ are straight lines.

Find angle TRD .

$$\text{Angle } AET = \frac{360}{7} = 51.428\dots$$

$$\text{Angle } SEA = 180 - 51.428\dots = 128.571\dots$$

$$\text{Angle } DEA = \frac{(5-2) \times 180}{5} = 108 \text{ (= angle } EDR)$$

$$\text{Angle } DET = 108 - 51.428\dots = 56.57142\dots$$

$$\text{Angle } ETR = 51.428\dots + 51.428\dots = 102.857\dots$$

$$\text{Angle } TRD = 360 - 56.57142\dots - 102.857\dots - 108$$

$$\text{Answer } \dots\dots\dots = 92.6 \dots\dots\dots [5]$$

25. The table below shows the distribution of three types of apartments in three blocks of flats.

	3-room	4-room	5-room
Block 1	10	20	50
Block 2	25	45	10
Block 3	30	50	20

The information can be represented by the matrix $T = \begin{pmatrix} 10 & 20 & 50 \\ 25 & 45 & 10 \\ 30 & 50 & 20 \end{pmatrix}$.

The floor areas of the 3-room, 4-room and 5-room apartments are 60 m^2 , 90 m^2 and 110 m^2

respectively and this information can be represented by the matrix $A = \begin{pmatrix} 60 \\ 90 \\ 110 \end{pmatrix}$.

- (a) Evaluate TA .

Answer $\begin{pmatrix} 7900 \\ 6650 \\ 8500 \end{pmatrix}$ [2]

- (b) Explain what the elements in TA represent.

Total floor areas in Block 1, Block 2 and Block 3 respectively.

..... [1]

- (c) Maintenance fees are charged based on the floor area of the apartments in the three blocks of flats. The maintenance fee rates ($\$/\text{m}^2$) for Block 1, 2 and 3 are \$3, \$4, and \$6 respectively. Write down a 1×3 matrix C to show the maintenance fee rates for the three blocks of flats.

Answer $(3 \ 4 \ 6)$ [1]

- (d) Hence, using matrix multiplication, find the total estate management fee for these three blocks of flats.

$$(3 \quad 4 \quad 6) \begin{pmatrix} 7900 \\ 6650 \\ 8500 \end{pmatrix}$$

(101300)

Answer [2]

26. (a) The first four terms of a sequence are 5, 9, 13 and 17.

The sum of the first n terms of this sequence is given by $an^2 + bn$.

- (i) When $n = 1$, $a + b = 5$.

Show that $4a + 2b = 14$.

Answer

$$\text{When } n = 2, \quad a(2)^2 + b(2) = 5 + 9$$

$$4a + 2b = 14$$

- (ii) Solve $a + b = 5$

$$4a + 2b = 14.$$

$$4a + 4b = 20$$

$$2b = 6 \Rightarrow b = 3$$

$$a = 2$$

Answer $a = \dots 2 \dots$

$b = \dots 3 \dots$ [2]

(b) The n th term of another sequence is $n^2 + 4$.

Anthony says,

“The n th term of the sequence is always a prime number when n is an odd number.”

Anthony is wrong.

Give an example to show that Anthony is wrong.

$$n = 1: (1)^2 + 4 = 5$$

$$n = 3: (3)^2 + 4 = 13$$

$$n = 5: (5)^2 + 4 = 29$$

$$n = 7: (7)^2 + 4 = 53$$

$$n = 9: (9)^2 + 4 = 85 \quad (\text{Not prime, hence Anthony is wrong}) \quad \text{A1 for one proof}$$

(can be for $n = 11$, etc.)

Or any n that is an odd number that does not give n th term a prime number

Answer [2]

~ End of Paper ~

1

Mark Scheme Math Prelim P 2 2023

1 (a) Solve $\frac{1}{x-1} + \frac{2}{x-2} = \frac{3}{x-3}$.

Question	Answer
1a	$\frac{3x-4}{x^2-3x+2} = \frac{3}{x-3}$
	$x = 1\frac{1}{2}$

Answer $x = \dots\dots\dots$ [2]

(b) Simplify $(a^2b)^{\frac{1}{2}} \times (ab^{-3})^{\frac{1}{3}}$.

Question	Answer
1b	$\frac{1}{a^2} \frac{1}{b^2}$

Answer $\dots\dots\dots$ [1]

(c) (i) Express $x^2 + 11x - 15$ in the form $(x+a)^2 + b$.

Question	Answer
1ci	$\left(x + 5\frac{1}{2}\right)^2 - 45\frac{1}{4}$

Answer $\dots\dots\dots$ [1]

(ii) Hence solve the equation $x^2 + 11x - 15 = 0$, giving your answers correct to two decimal places.

Question	Answer
1cii	$\left(x + 5\frac{1}{2}\right)^2 = 45\frac{1}{4}$ $x + 5\frac{1}{2} = \pm\sqrt{45\frac{1}{4}}$ $x = 1.23$ or -12.23

Answer $x = \dots\dots\dots$ or $\dots\dots\dots$ [3]

2

Mark Scheme Math Prelim P 2 2023

(d) Simplify $\frac{3a^2 + 12a - 36}{4b - 2b + a^2 - 2a}$.

Question	Answer
1d	$\frac{3(a+6)(a-2)}{b(a-2)+a(a-2)}$ $\frac{3a+18}{b+a}$

Answer $\dots\dots\dots$ [3]

Mark Scheme Math Prelim P 2 2023

- (c) On 1 June 2022, Ben changed S\$6200 into American dollars. The exchange rate between American dollars (US\$) and Singapore dollars (S\$) was US\$1 = S\$1.37.

(i) Calculate the amount of American dollars he would receive.

Question	Answer
2ci	$\frac{6200}{1.37} = 4525.55$

Answer \$..... [2]

- (ii) On a trip to the USA, Ben bought a tablet for US\$1899 from a department store. When Ben bought the tablet, the store made a profit of 8%. Calculate how much the store paid for the tablet.

Question	Answer
2ci	$\frac{6200}{1.37} = 4525.55$

Answer \$..... [2]

Mark Scheme Math Prelim P 2 2023

- 2 (a) Abigale has two possible options to invest a sum of money for 3 years.

Account A pays compound interest 6%, 8% and 10% for the 3 years respectively.
 Account B pays compound interest 10%, 8% and 6% for the 3 years respectively.

Explain which, if any, is a better choice for Abigale's investment.

Question	Answer
2a	Both accounts pays the same compound interest. A: $P \times 1.06 \times 1.08 \times 1.1$ B: $P \times 1.1 \times 1.08 \times 1.06$

..... [1]

- (b) An amount of \$3750 was placed in an account that pays simple interest. After 3 years, the balance was \$4620.

(i) Find the rate of interest

Question	Answer
2bi	$\text{Interest per yr} = \frac{4620 - 3750}{3} = \290 $\text{Interest rate} = \frac{290}{3750} \times 100\% = 7\frac{11}{15}\%$

Answer% [2]

- (ii) If the same interest is paid using compound interest, calculate the balance in the account after the same time period.

Question	Answer
2bit	$\text{Bal} = 3750 \left(1 + \frac{7\frac{11}{15}}{100} \right)^3$ $= 46898.01$

Answer \$..... [2]

- (b) In the previous year, the same race had taken place. The box-and-whisker plot shows the distribution of the speed of the cyclists.

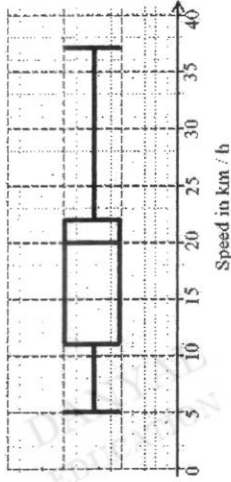

Make two comparisons between the performances of the cyclists in the two years. Use figures to support your answer.

3b	<p>Median of previous year = 20, higher than median of current year (11). Better performance in previous year.</p> <p>IQR of previous yr = 11 which is higher than IQR of current yr (10). Current yr's performance is more consistent</p>
----	--

- 3 The cumulative frequency graph below shows speeds in km/h of cyclists passing a certain point during a race.

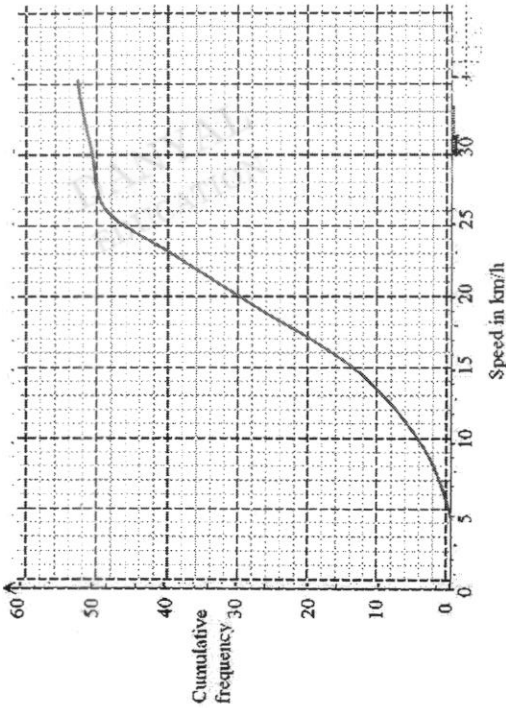

- (a) Use the curve to estimate
- (i) the median speed of the cyclists, Answer 19 km/h [1]
 - (ii) the percentage of cyclists having speed more than 21 km/h
Answer 38.5 % [1]
 - (iii) the ninety-sixth percentile.
Answer 30 km/h [1]

- (iii) Complete the grouped frequency table of the speeds of the cyclists passing a certain point during the race.

Speed (x km/h)	$5 \leq x < 10$	$10 \leq x < 15$	$15 \leq x < 20$	$20 \leq x < 25$	$25 \leq x < 30$	$30 \leq x < 35$
Frequency	4	9	16	$16/7$	$5/4$	2

[2]

DANYAL EDUCATION

- 4 The variables x and y are connected by the equation

$$y = \frac{x^2}{5} + \frac{6}{x}$$

The table below shows some values of x and the corresponding values of y , correct to 1 decimal place.

- (a) Complete the table.

x	1	1.5	2	3	4	5	6
y	6.2	4.5	3.8	3.8	4.7	6.2	<u>8.2</u>

[1]

- (b) On the grid at the next page, draw the graph of $y = \frac{x^2}{5} + \frac{6}{x}$ for $1 \leq x \leq 6$.

[3]

- (c) Use your graph to find the value(s) of x in the range of $1 \leq x \leq 6$ for which

$$\frac{x^2}{5} + \frac{6}{x} - 4 = 0.$$

Question	Answer
4c	1.8 3.3

Answer $x = \dots\dots\dots$ [2]

- (d) By drawing a tangent, find the gradient of the curve at point (4, 4.7).

Question	Answer
4d	Tangent line drawn Gradient = $1.225 \pm 10\%$

Answer $\dots\dots\dots$ [2]

- (e) By drawing the graph $y = \frac{1}{2}x + 4$ on the grid, find the equation in the form

$$2x^2 + ax^2 + bx + c = 0,$$

which is satisfied by the x -coordinates of the points at which the two graphs intersect.

Question	Answer
4e	Line drawn $\frac{x^2}{5} + \frac{6}{x} = \frac{1}{2}x + 4$ $2x^3 - 5x^2 - 40x + 60 = 0$

Answer $\dots\dots\dots$ [4]

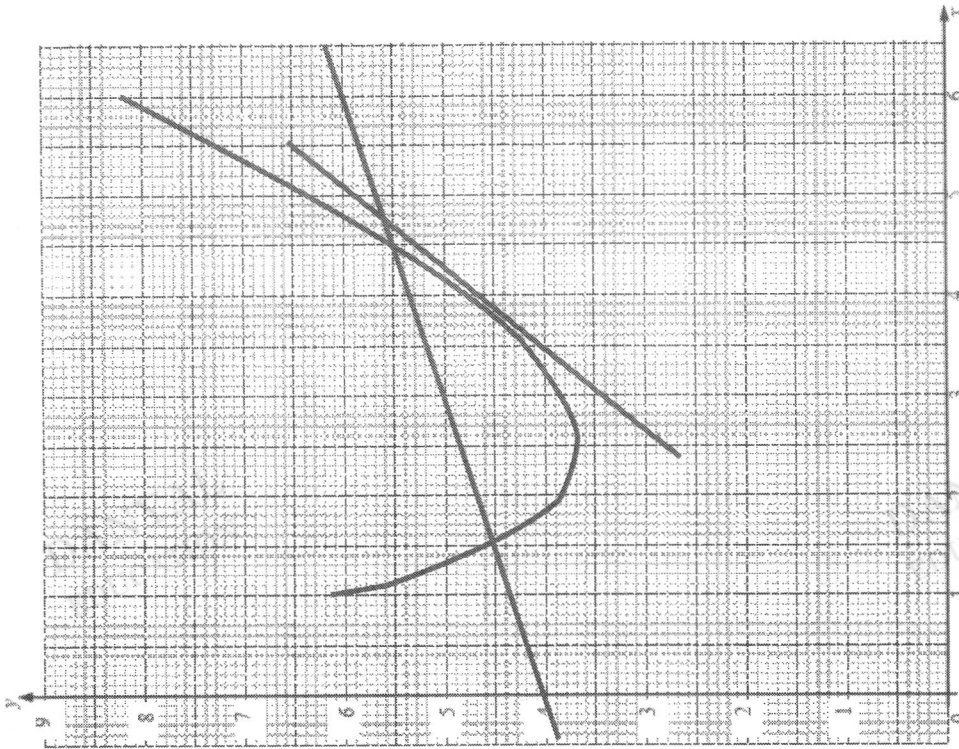

- (c) The solid cube is placed inside an open cylindrical container which has base radius 6 cm and height 13 cm.

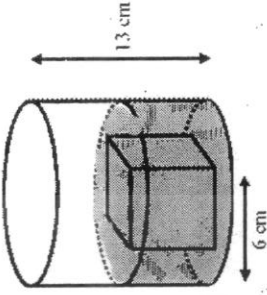

V cm³ of water is poured into the container at a rate of $2.5 \text{ cm}^3/\text{s}$ until it covers the cube as shown in the diagram above.

- (f) Calculate the amount of time, in seconds, it takes for all the water to be poured in.

Question	Answer
5ci	V $= \pi(6)^2(8.0599)$ $= \frac{4}{3}\pi(5)^3$ $= 387.95 \text{ cm}^3$ $\text{Time required} = \frac{387.95}{2.5}$ $= 155.18 \text{ (3s.f.)}$

- (ii) When the cube is removed from the container, the water level drops by x cm. Assuming that the water loss is negligible upon the removal of the cube, calculate the value of x .

Question	Answer
5ci	<p>Let the current height be h cm.</p> $387.95 = \pi(6)^2h$ $h = 3.4302$ $x = 8.0599 - 3.4302$ $= 4.63$

- 5 The diagram below shows a solid cube ABCDEFGH.

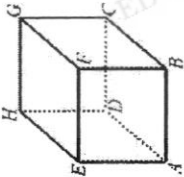

- (a) The solid cube was produced after recasting a solid spherical toy with diameter 10 cm. Show that the length of a side of the cube is approximately 8.06 cm.

Question	Answer
5a	$\text{Length of cuboid} = \sqrt[3]{\frac{4}{3}\pi(5)^3}$ $= 8.0599$ $= 8.06 \text{ cm}$

Answer cm [2]

- (b) An ant is crawling from the point A . Find the shortest distance that it can take from point A to point G .

Question	Answer
5b	<p>Let M be the midpoint of EF.</p> <p>The shortest distance is obtained if the path taken is AM, followed by MG.</p> <p>shortest distance = $AM + MG$</p> $= 2AM \quad (\text{since } AM=MG)$ $= 2\sqrt{AE^2 + EM^2}$ $= 2\sqrt{8.0599^2 + \left(\frac{1}{2}(8.0599)\right)^2}$ $= 18.0224$ $= 18.0 \text{ cm (3s.f.)}$

Answer cm [2]

Answer s [4]

Answer cm [2]

(c) Calculate DE.

Question	Answer
6c	$DA = 10 \cos 36^\circ$ $\angle DEA = 78^\circ$ $\frac{DE}{\sin 36^\circ} = \frac{10 \cos 36^\circ}{\sin 78^\circ}$ $DE = 4.861518423$ ≈ 4.86

Answer cm [4]

(d) Calculate the length of the minor arc BC.

Question	Answer
6d	$\angle BOC = 48^\circ$ Arc length = $\frac{48}{360} \times 2\pi \times 5$ $= 4.18879$ ≈ 4.19 cm

Answer cm [3]

6 In the diagram, A, B, C and D are points on the circle with centre O. The lines AC and BD intersect at E. The tangent to the circle at C meets AD produced at T. $\angle ACB = 66^\circ$, $\angle CAD = 36^\circ$ and $AC = 10$ cm.

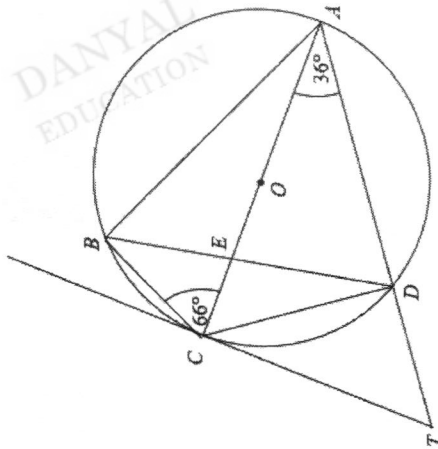

(a) Find the angle DCT.

Question	Answer
6a	Angle DCA = 54° 36°

Answer [2]

(b) Show that the triangles BCE and ADE are similar. Give a reason for each statement you make.

Question	Answer
6b	Angle BEC = Angle AED (vert. opp \angle) Angle CBE = Angle DAE (\angle in same seg) triangles BCE and ADE are similar (AA similarity test)

..... [2]

13

Mark Scheme Math Prelim P 2 2023

7 A city tour starting at Hotel A is planned. The coach travels 43 km in the north-west direction to B, the zoo, where it stops for 3 hours. After the visit to the zoo, the coach continues its journey to a popular seafood restaurant at C, 18 km away, for lunch. After lunch, the coach brings the tourists to visit a museum at D, 24 km away and $\angle CDA = 85^\circ$.

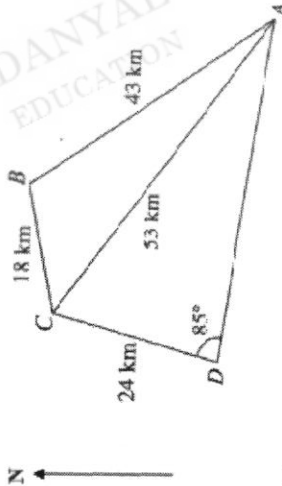

(a) Find
(i) $\angle BAC$.

Question	Answer
7a	$\angle BAC = \cos^{-1} \left(\frac{53^2 + 43^2 - 18^2}{2(53)(43)} \right)$ $= 18.0372 \approx 18.0^\circ$

Answer [2]

(ii) $\angle CAD$.

Question	Answer
7b	$\angle CAD = \sin^{-1} \left(\frac{24 \sin 85^\circ}{53} \right)$ $= 26.8^\circ$

Answer [2]

14

Mark Scheme Math Prelim P 2 2023

(b) Find the bearing of C from A.

Question	Answer
7b	$360^\circ - 45^\circ - 18.0^\circ$ $= 297.0^\circ$

Answer [2]

(c) Calculate the shortest distance from D to AC.

Question	Answer
7b	$\text{Angle } DAC = 68.2^\circ$ $\text{Shortest dist} = 24 \times \sin 68.2^\circ$ $= 22.2836 \dots$ $= 22.3$

Answer km [3]

16

Mark Scheme Math Prelim P 2 2023

- (b) The points A and D is shown in the grid below and $\vec{AB} = \begin{pmatrix} 10 \\ 5 \end{pmatrix}$.

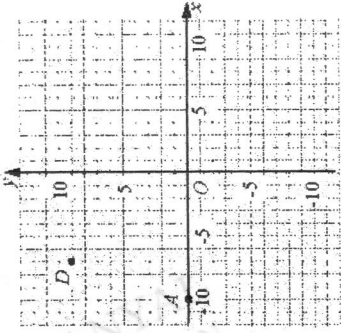

- (i) Find $|\vec{AB}|$.

Question	Answer
8bi	11.2

Answer [1]

- (ii) Find the equation of the line BD .

Question	Answer
8bii	Gradient $BD = \frac{-4}{7}$ $y = -\frac{4}{7}x + 5$

Answer [2]

15

Mark Scheme Math Prelim P 2 2023

- 8 (a) $OABC$ is a trapezium where $\vec{OD} = \mathbf{p}$ and $\vec{OC} = \mathbf{q}$, OB and CD meet at X . $AB \parallel OC$ and $OD = \frac{1}{3}OA$.

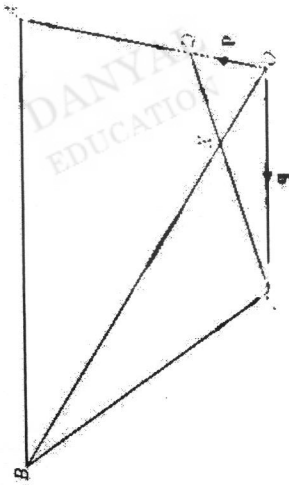

5N ONLY

- (i) Given that $\vec{CX} = h\vec{CD}$, show that $\vec{OX} = h\mathbf{p} + (1-h)\mathbf{q}$.

Question	Answer
8ai	$\vec{CD} = -\mathbf{q} + \mathbf{p}$ $\vec{CX} = h(-\mathbf{q} + \mathbf{p}) = -h\mathbf{q} + h\mathbf{p}$ $\vec{OX} = \mathbf{q} + -h\mathbf{q} + h\mathbf{p}$

Answer shown [3]

- (ii) Given further that $\vec{OX} = k\vec{OB}$, find the value of h and of k .

Question	Answer
8aii	$\vec{AB} = 2\mathbf{q}$ $\vec{OB} = 3\mathbf{p} + 2\mathbf{q}$ $\vec{OX} = h\mathbf{p} + (1-h)\mathbf{q} = 3k\mathbf{p} + 2k\mathbf{q}$ $k = \frac{1}{5}, h = \frac{3}{5}$

Answer $h = \dots, k = \dots$ [4]

(b) The table shows the number of cars owned by each of 25 families.

1	3	0	2	1
3	1	6	0	1
4	2	1	3	2
0	1	3	2	4
2	0	2	1	3

(i) A family is chosen at random. Find the probability that it owns 3 cars.

Question	Answer
9bi	$\frac{1}{5}$

Answer [1]

(ii) Two families are chosen at random. Find the probability that one family owns 2 cars and the other owns more than 3 cars.

Question	Answer
9bii	$\frac{6 \times 5}{25 \times 24} + \frac{5 \times 6}{25 \times 24}$ $\frac{1}{10}$

Answer [4]

(iii) A car is chosen at random. Find the probability that it belongs to a family which owns 2 cars.

Question	Answer
9bit	$\frac{12}{48} = \frac{1}{4}$

Answer [2]

8/9 (a) $\xi = \{\text{integers } x: 0 < x < 12\}$
 $P = \{\text{even numbers}\}$
 $Q = \{\text{prime numbers}\}$

(i) List the elements in P.

Question	Answer
9ai	2, 4, 6, 8, 10

Answer [1]

(ii) List the elements in $(P \cup Q)$.

Question	Answer
9aif	1, 9

Answer [1]

(iii) Complete the Venn diagram showing all the elements of ξ .

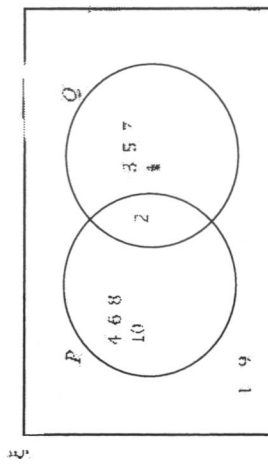

[1]

(iv) Find the value of

(a) $n[(P \cap Q) \cup Q^c]$

Question	Answer
9aiva	7

Answer [1]

(b) $n[(P \cup Q) \cap (P \cap Q)^c]$

Question	Answer
9aivb	8

Answer [1]

- (c) Mr Wong's family use the air-conditioning in their bedrooms from 7pm to 6am and the living room from 5pm to 10pm daily. On Saturday and Sundays, Mr Wong will use the living room air-conditioning for an extra 3 hours before 5pm.

(i) Determine with explanation which of the packages is suitable for Mr Wong.

Question	Answer
10ci	B Living room requires more than 9000 btu/hr

Answer Package because [1]

- (ii) Calculate the cost of electricity usage (inclusive of GST 8%) by Mr Wong's family for air-conditioning for the month of July 2023.

Question	Answer
10cii	<p>Bedrooms: $20W \times 2units \div 11hr \div 31 days$ $= 13640W/hr = 13.64 kW/hr$</p> <p>Living Room: Everyday: $24W \times 5hr \div 31 days$ $= 3720 kW/hr = 3.72 kW/hr$ Weekend: $24W \times 3hr \div 10 days$ $= 720 kW/hr = 0.72 kW/hr$</p> <p>Outdoor Unit: Everyday: $1420W \div 13hr \div 31 days$ $= 57260 kW/hr = 572.26 kW/hr$ Weekend: $1420W \times 3hr \div 10 days$ $= 42600 kW/hr = 42.6 kW/hr$ Total = 632.94 kW/hr</p> <p>Cost = $632.94 kW/hr \times 29.96 cents$ $= \\$189 628824$ $\approx \\$189.63$</p>

Answer \$. [7]

- 9/10 Air-conditioners are designed to control both the air temperature and humidity. Choosing the right cooling capacity for your air-conditioner is important for proper comfort and energy optimisation.

An oversized air-conditioning system is costly and may cost more to operate. It might also not properly dehumidify the space. This is because the air-conditioner cools the space too quickly and then powers down before the moisture level is reduced. On the other hand, an undersized air-conditioning system will not provide adequate cooling and dehumidification. To properly size your air conditioning system, a useful rule of thumb is as follows:

$$\text{Cooling capacity required in kW} = \text{Total aircon floor area (m}^2\text{)} \div 5$$

to convert to Btu/hr, multiply the cooling capacity figure in kW by 3,412

Mr Wong has recently purchased an apartment and would like to install air-conditioning units to the Main-bedroom, Bedroom, and the Living room.

- (a) Find the total floor area of the rooms to be air-conditioned in m².

Question	Answer
10a	$\text{Main Bedroom} + \text{Bedroom} + \text{Living Room}$ $= (4.2 \times 3.1) + (4.1 \times 3.1) + (6 \times 2.9)$ $= 13.02 + 12.71 + 17.4 = 43.13$

Answer m² [2]

- (b) Calculate the required Btu/hr for each of the rooms.

Question	Answer
10b	Main Bedroom = 8885 Bedroom = 8673 Living Room = 1190

Answer Main Bedroom Bedroom Living room [1]

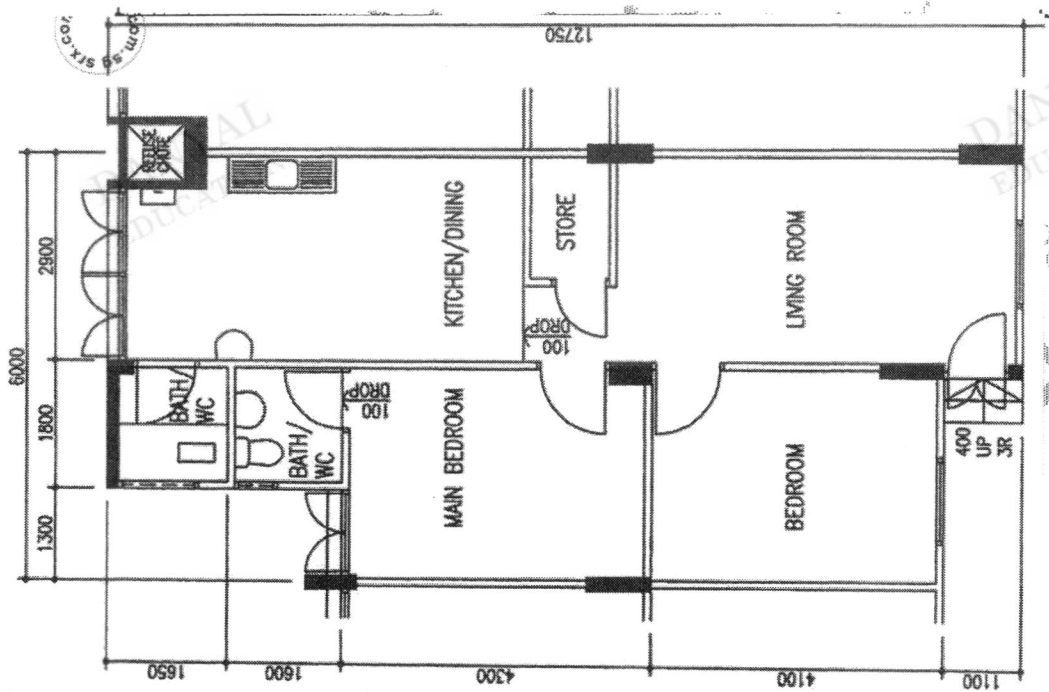

Floorplan of apartment. All measurements are measured in mm.

Package A	Package B	Package C	Package D
<p>MIDEA INVERTER SYSTEM 3 AIR-CON MAE-3M21D / MS21D- 09 X1 • MS21D-12 X 214 TICKETS) INSTALLATION INCLUDED S\$3,149.00 552-275759 (Home Pro) ☆☆☆☆☆☆ ADD TO CART Add to Wish List</p>	<p>MIDEA INVERTER SYSTEM 3 AIR-CON MAE-3M21D / MS21D- 09 X2 • MS21D-12 X 114 TICKETS) INSTALLATION INCLUDED S\$3,099.00 552-275759 (Home Pro) ☆☆☆☆☆☆ ADD TO CART Add to Wish List</p>	<p>MIDEA INVERTER SYSTEM 3 AIR-CON MAE-3M21D / MS21D- 12 X 3 (4 TICKETS) INSTALLATION INCLUDED S\$3,249.00 552-275759 (Home Pro) ☆☆☆☆☆☆ ADD TO CART Add to Wish List</p>	<p>MIDEA INVERTER SYSTEM 3 AIR-CON MAE-3M21D / MS21D- 12 X 3 (4 TICKETS) INSTALLATION INCLUDED S\$3,249.00 552-275759 (Home Pro) ☆☆☆☆☆☆ ADD TO CART Add to Wish List</p>

Power consumption	9000 btu/hr unit	12000 btu/hr	Outdoor unit
	20W	24W	1420W

Electricity Consumption (kWh) = Power consumption(kW) / time (hours)

1kW = 1000W

July 2023

Day	Monday	Tuesday	Wednesday	Thursday	Friday	Saturday
1						1
2	3	4	5	6	7	8
9	10	11	12	13	14	15
16	17	18	19	20	21	22
23	24	25	26	27	28	29
30	31					

29.96 cents/kWh

27.74 cents/kWh (w/o GST)
ELECTRICITY TARIFF
(wef: Jul - 30 Sep 23)