

Name and Index Number: ()	Class:
---	--------



SENG KANG SECONDARY SCHOOL 2023 END OF YEAR EXAMINATION

PHYSICS (REVISED)

6091/01

Secondary 3 Express

5 October 2023

Paper 1 Multiple Choice

1 hour

Additional Materials: Multiple Choice Answer Sheet

READ THESE INSTRUCTIONS FIRST

Write with a soft pencil.

Write your index number and name on all the work you hand in.

Do not use staples, paper clips, highlighters, glue or correction fluid.

There are **forty** questions in this paper. Answer **all** questions. For each question there are four possible answers **A, B, C** and **D**.

Choose the **one** you consider correct and record your choice in soft pencil on the separate Multiple Choice Answer Sheet.

Read the instructions on the Answer Sheet very carefully.

Each correct answer will score one mark. A mark will not be deducted for a wrong answer.

Any rough working should be done in this question paper.

The use of an approved scientific calculator is expected, where appropriate.

Parent's / Guardian's Signature:

This document consists of **14** printed pages.

Do not turn over the page until you are told to do so.

1 Which of the following is equivalent to 0.37 g / cm^3 ?

- A 0.037 kg / m^3
- B 37 kg / m^3
- C $3.7 \times 10^2 \text{ kg / m}^3$
- D $3.7 \times 10^4 \text{ kg / m}^3$

2 A measured quantity is written as 0.78 ms .

What is the SI unit of this measurement?

- A metres
- B metres per second
- C millisecond
- D second

3 A length of string is measured between two points on a ruler.

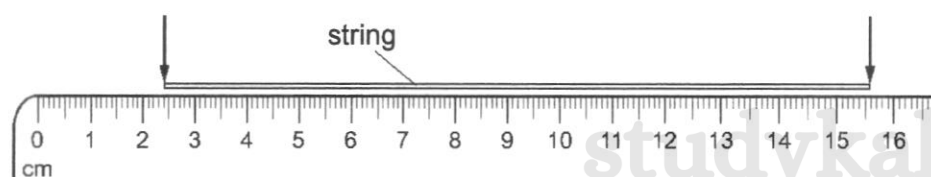

When the length of string is wound closely around a pen, it goes round six times.

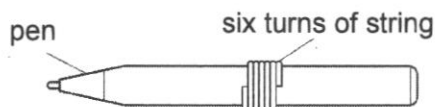

What is the circumference of the pen where the string is wound around?

- A 2.2 cm
- B 2.6 cm
- C 13.2 cm
- D 15.6 cm

4 A parachutist initially at rest, falls through the air from a high altitude during an air show display. Air resistance acts on him and he reaches terminal velocity after some time.

Which quantity **decreases** until he reaches his terminal velocity?

- A acceleration
- B kinetic energy
- C speed
- D weight

- 5 A traffic police car starts from rest and accelerates to catch up with a speeding motorcyclist within t minutes.

Which graph shows the above scenario?

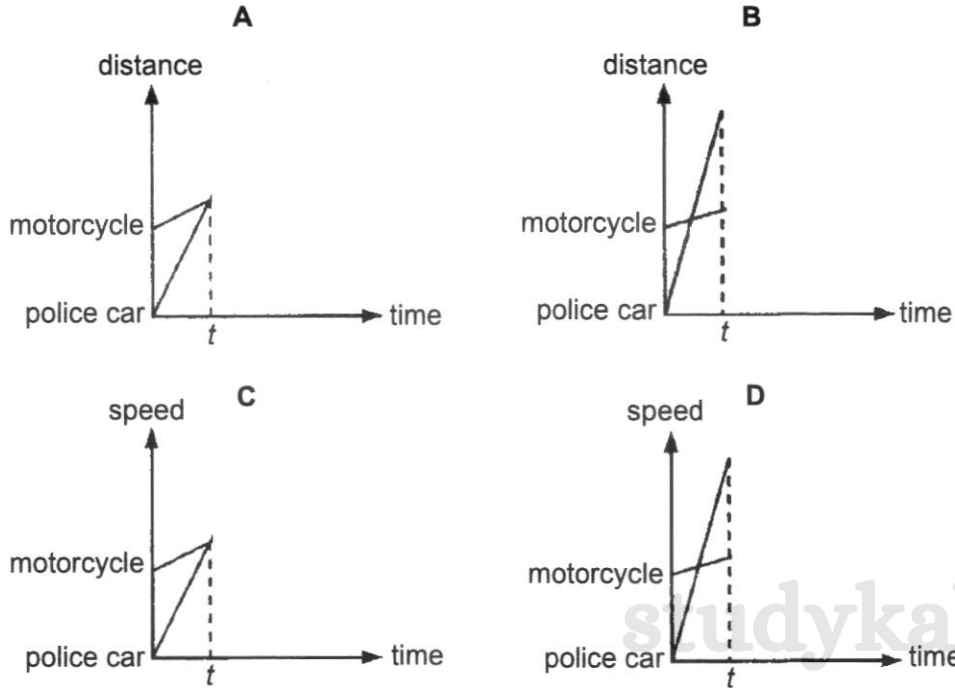

- 6 The graph shows how the velocity of an object changes with time.

Which section of the graph shows the object moving with **decreasing** acceleration?

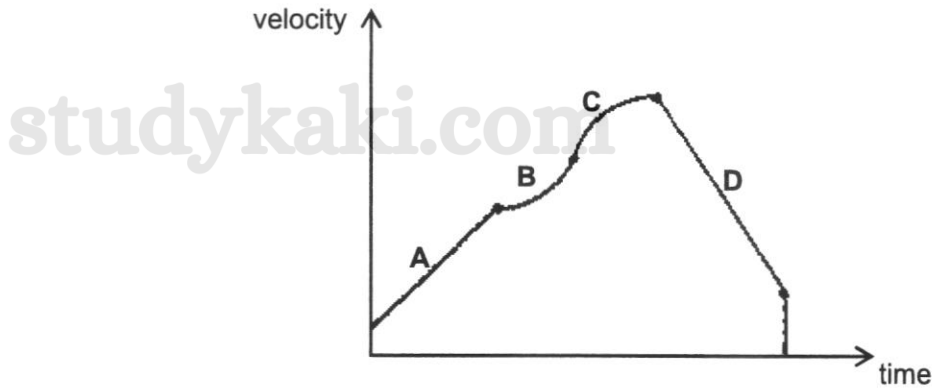

- 7 A cyclist who was moving at a constant speed of 36 km/h, braked with a uniform deceleration and stopped in a distance of 4.0 m.

How long did he take to stop upon braking?

- A 0.40 s
- B 0.80 s
- C 1.3 s
- D 2.5 s

- 8 A car travels 6.0 km to the West, 8.0 km to the North, 6.0 km to the East and finally 8.0 km to the South.

What is the displacement of the car?

- A 0 km
 B 10 km
 C 14 km
 D 28 km
- 9 To avoid an accident, the brakes of a car that was travelling at 25 m/s were applied instantaneously. The driver of the car has a mass of 90 kg and the car took 2.5 s to decelerate to rest.

What is the average force exerted by the safety belt on the driver during this period?

- A 90 N
 B 225 N
 C 900 N
 D 2250 N
- 10 Four forces act vertically and horizontally on a point as shown.

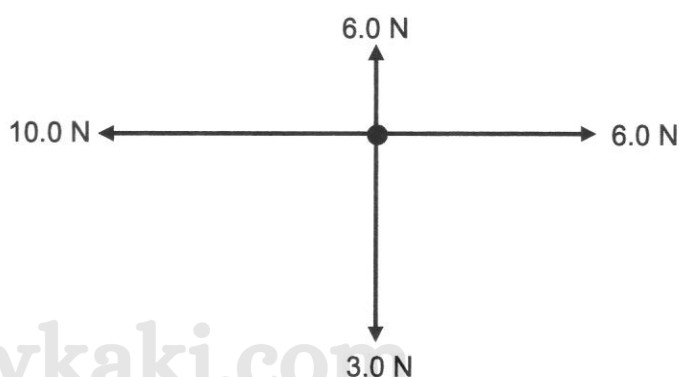

What is the size of the resultant force?

- A 3.0 N
 B 4.0 N
 C 5.0 N
 D 7.0 N
- 11 A box of mass 10 kg is moving along a rough, horizontal surface, which provides an average frictional force f . A force F is constantly applied to the box and it moves with a constant speed of 1.0 m/s.

What are the values of F and f ?

	F/N	f/N
A	15	10
B	15	15
C	20	10
D	25	10

- 12 A person weighing 700 N at the bottom of a mountain starts his climb upwards. The gravitational field strength acting on him changes from 10.0 N/kg at the bottom of the mountain to 9.97 N/kg at the top of the mountain.

What is the weight and mass of the person at the top of the mountain?

	weight / N	mass / kg
A	698	70.0
B	698	70.2
C	700	70.0
D	700	70.2

- 13 Four identical objects are each acted on by only two forces, as shown.

Which object is in equilibrium?

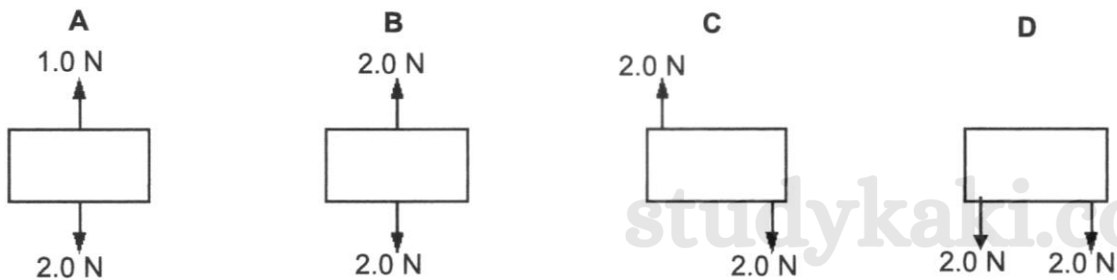

- 14 The number of passengers allowed at the top deck of the double-decker bus is limited.

Why is this so?

- A** a higher mass at the top deck causes a smaller turning effect on the bus
B a higher mass at the top deck lowers the centre of gravity of the bus
C the stability of the of bus increases with fewer passengers at the top
D the top part of the bus is made smaller to be more streamlined in design

- 15 A uniform metre rule is balanced by a 4.0 N weight as shown in the diagram.

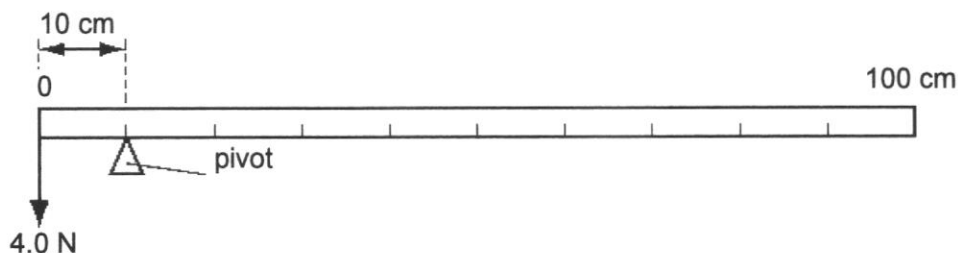

What is the mass of the metre rule?

- A** 0.10 kg
B 0.40 kg
C 1.0 kg
D 4.0 kg

- 16 A heavy beam rests on two supports. The diagram shows the three forces F_1 , F_2 and F_3 , acting on the beam.

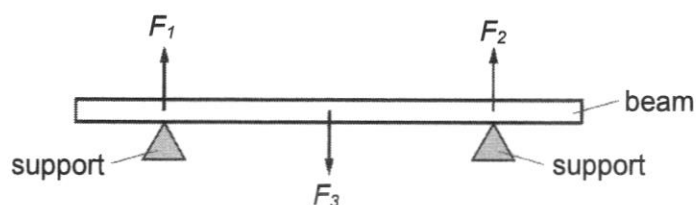

The beam is in equilibrium.

Which statement is correct?

- A All the forces are equal in magnitude.
 B The resultant force on the beam is in the opposite direction to the resultant turning effect.
 C The resultant force on the beam is zero and the resultant turning effect on the beam is zero.
 D The total upward force is twice the downward force.
- 17 A hole is made in a square tile of uniform thickness. The diagram shows the tile hanging loosely on a nail.

Where is the centre of gravity of the tile?

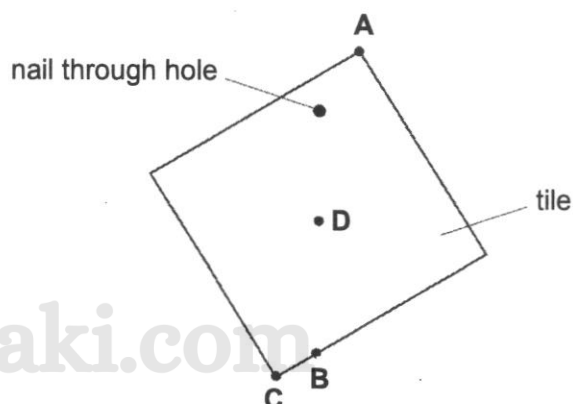

- 18 A metal cone with a circular base is placed on a flat surface.

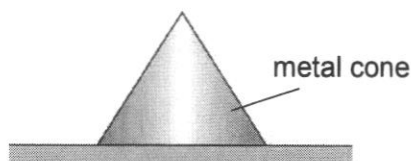

A student lists the possible factors affecting the stability of the metal cone:

- I centre of gravity
 II diameter of base
 III weight

Which factor(s) affects the stability of the metal cone?

- A I only B II only C I and II only D I, II and III

- 19 A student uses her thumb to push a thumb tack into a notice board. The thumb tack goes into the board but does not penetrate her thumb.

Which statement explains this?

- A The force exerted by the thumb tack on her thumb is greater than the force exerted by the thumb tack on the notice board.
- B The force exerted by the thumb tack on the notice board is greater than the force exerted by the thumb tack on her thumb.
- C The pressure of the thumb tack on her thumb is greater than the pressure of the thumb tack on the notice board.
- D The pressure of the thumb tack on the notice board is greater than the pressure of the thumb tack on her thumb.

- 20 A book has a mass of 400 g. The surface of the book in contact with a table has dimensions 0.10 m by 0.20 m. The gravitational field strength g is 10 N/kg.

What is the pressure exerted on the table by the book?

- A 0.08 N/m²
- B 8.0 N/m²
- C 20 N/m²
- D 200 N/m²

studykaki.com

- 21 An inflated balloon is placed under a vacuum bell jar.

Diagram 1 shows the balloon after the pump is turned on for several minutes.

The pump is then turned off and air is allowed to re-enter the bell jar. Diagram 2 shows the subsequent size of the balloon.

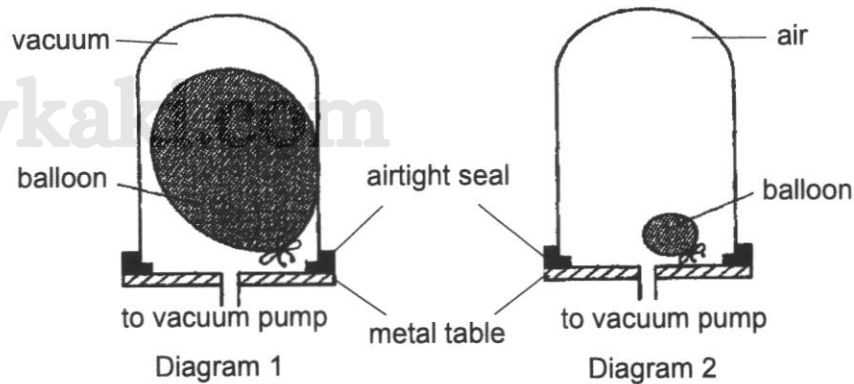

What pressure change occurs within the bell jar and within the balloon?

	pressure change in the bell jar	pressure change in the balloon
A	decrease	decrease
B	decrease	increase
C	increase	decrease
D	increase	increase

- 22 The diagram shows the vertical sections of a set of circular vessels, each containing the same depth but different volumes of water.

volume of water in vessel P = 140 cm^3
 volume of water in vessel Q = 100 cm^3
 volume of water in vessel R = 140 cm^3
 volume of water in vessel S = 210 cm^3

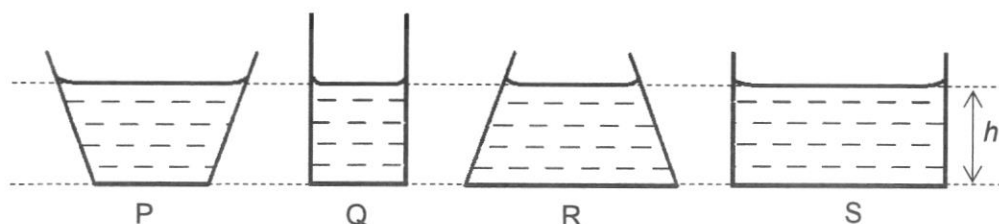

Which statement is correct?

- A All of the vessels exert the same pressure at a depth of h .
 B Vessel P exerts a higher pressure than R at a depth of h .
 C Vessel R exerts a higher pressure than Q at a depth of h .
 D Vessel S exerts the highest pressure at a depth of h .

- 23 The diagram shows a simple manometer.

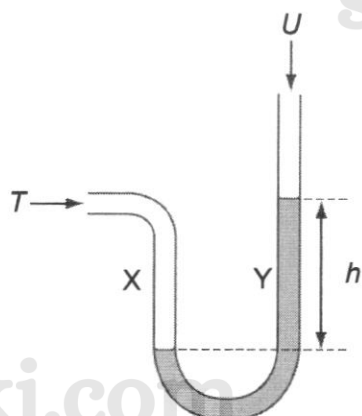

Side X is connected to a gas supply with a gas pressure T . Side Y is exposed to the atmospheric pressure, U .

What pressure does height h measure?

- A atmospheric pressure
 B difference between gas pressure T and atmospheric pressure U
 C gas pressure T
 D sum of the gas pressure T and atmospheric pressure U

24 The diagram shows a simple mercury barometer.

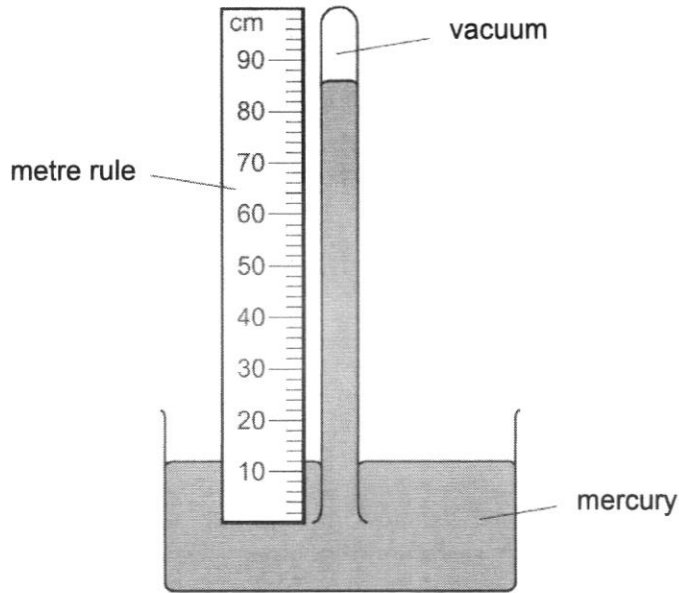

Which length is used to find the value of the atmospheric pressure?

- A 12 cm
- B 74 cm
- C 86 cm
- D 100 cm

studykaki.com

25 The diagram shows an ideal simple hydraulic system.

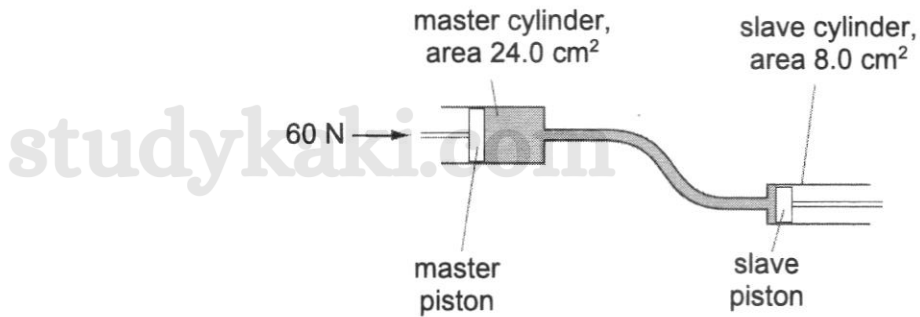

The cross-sectional area of the piston at the master cylinder is 24.0 cm^2 and the cross-sectional area of the piston at the slave cylinder is 8.0 cm^2 .

Which row is correct?

	pressure at the slave cylinder / (N/cm^2)	force at the slave cylinder / N
A	0.83	20
B	0.83	60
C	2.5	20
D	2.5	60

- 26 A 1.0 kg metal block has the dimensions shown.

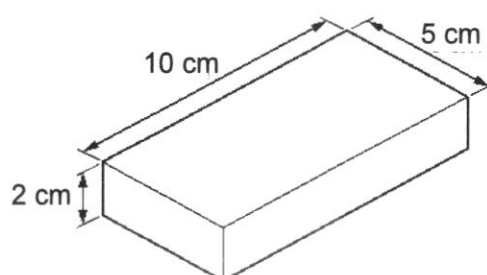

What is the density of the object?

- A 0.010 g/cm³
 B 10 g/cm³
 C 20 g/cm³
 D 100 g/cm³
- 27 The mass and volume of four different objects are plotted as shown.

Which object has the highest density?

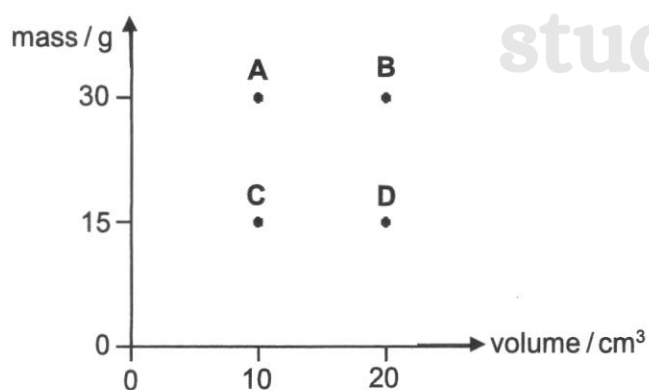

- 28 Which of the following are potential energy store(s)?

- I elastic
 II nuclear
 III internal
 IV chemical

- A I and IV only
 B II and III only
 C I, II and III only
 D I, II and IV only

- 29 A student suggests that there are several ways of transferring energy to a small, stationary block of iron on a smooth table. He makes the following suggestions.

- I Heat it.
- II Shine light on it.
- III Pass a current through it.

Which suggestions are correct?

- A I and II only
 - B I and III only
 - C I, II and III
 - D II and III only
- 30 A boy throws a ball upwards from his hand at P and it follows a parabolic path before reaching the ground as shown.

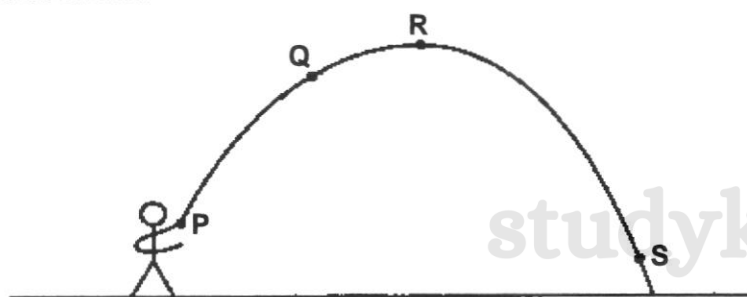

Which statement is correct?

- A At P, the ball has the same total energy compared to other points.
- B At Q, the ball is moving upwards with decreasing gravitational potential energy and increasing kinetic energy.
- C At R, the ball is experiencing zero acceleration due to gravity.
- D At S, the ball has a smaller kinetic energy since it is decelerating.

- 31 The graph shows how the height of a bouncing ball changes with time.

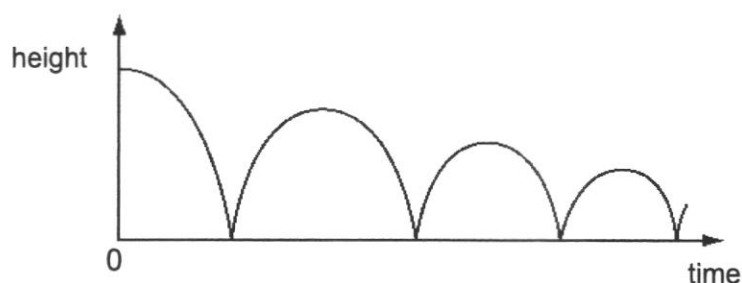

Which statement explains why the height of the ball **decreases** after each bounce?

- A At each bounce, energy is transferred to the internal store of the surrounding.
- B Kinetic energy is transferred to the potential energy store at each bounce.
- C The ball becomes worn out by the friction at every bounce.
- D The ball gains kinetic energy on impact with the floor.

- 32 A 7.0 g cylindrical bullet is fired from a gun and leaves the gun's barrel at an initial speed of 460 m/s. Air resistance reduces its velocity to 370 m/s just before it hits the target board.

What is the **loss** in kinetic energy of the bullet as it travels through the air to the target?

- A 0.0284 kJ
 B 0.261 kJ
 C 28.4 kJ
 D 261 kJ

- 33 A wooden block weighing 50 N is pulled up a rough inclined plane at a constant speed by a force of 80 N parallel to the inclined plane. When the distance moved along the plane is 10 m, the increase in height is 1.0 m as shown.

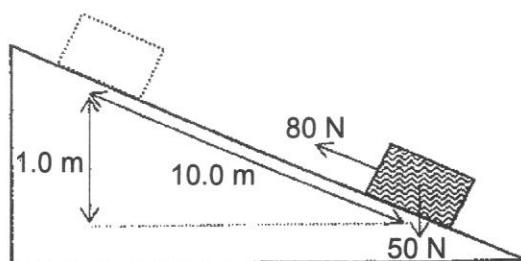

Which statement is correct?

- A The total work done in bringing the wooden block up is 50 J.
 B The total work done in bringing the wooden block up is 750 J.
 C The total work done in bringing the wooden block up is 800 J.
 D The total work done in bringing the wooden block up is 850 J.

- 34 Two men, X and Y, try to move identical heavy boxes, P and Q. Man X tries to push box P along the floor. The box does not move because an object is in the way.

Man Y lifts box Q from the floor onto a shelf.



Which man does the most work on their box, and which box gains the most energy?

	man doing most work	box gaining most energy
A	X	P
B	X	Q
C	Y	P
D	Y	Q

- 35 An engine produces 240 kJ of energy in 2.0 minutes.

What is the power output of the engine?

- A 2.0 kW
 B 120 kW
 C 480 kW
 D 28 800 kW
- 36 Very small pollen grains are suspended in water. A bright light shines from the side. When looked at through a microscope, small specks of light are seen to be moving in a random, jerky manner.

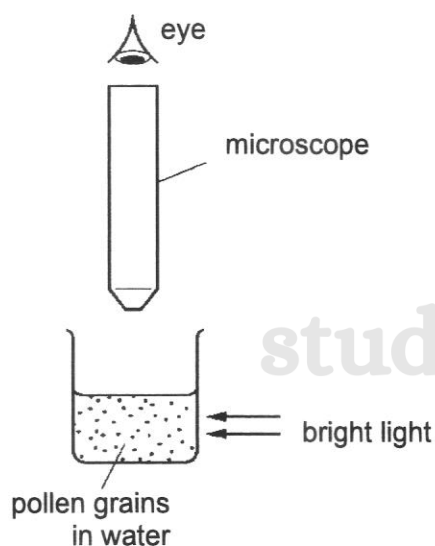

What are the moving specks of light?

- A pollen grains being hit by other pollen grains
 B pollen grains being hit by water molecules
 C water molecules being hit by other water molecules
 D water molecules being hit by pollen grains
- 37 Some gas is heated in a rigid sealed container.
- Which statement(s) is/are true?
- I The average distance between the gas molecules increases.
 II The kinetic energy of the gas molecules increases.
 III The frequency of the collision of the gas molecules with the inner walls of the container remains the same.
- A I only
 B II only
 C I and II only
 D II and III only

- 38 Two students carry out different experiments to compare the abilities of different metals to conduct thermal energy.

In Experiment 1, the bar is heated for one minute and the length of wax strip that melts is measured.

In Experiment 2, the bar is heated and the time taken for the pin to drop off is measured.

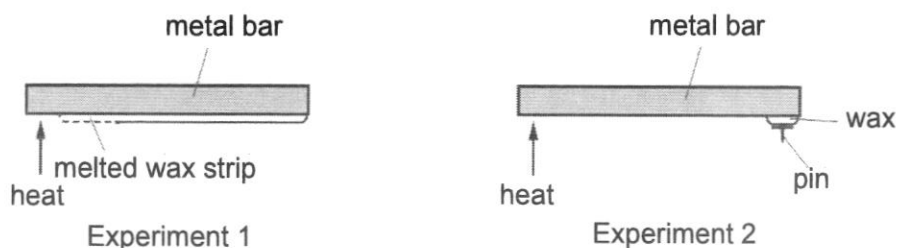

What happens to each of these measurements when a better thermal conductor is tested?

	length of melted wax strip	time taken for the pin to drop
A	decrease	decrease
B	decrease	increase
C	increase	decrease
D	increase	increase

- 39 In which substance(s) is convection a method of thermal energy transfer?

- A** air only
- B** air and water only
- C** air, water and wood
- D** wood only

- 40 Double-glazed glass windows have trapped air between two panes of glass. They are used to prevent unnecessary loss of heat from inside the house during winter.

Which transfer(s) of thermal energy is **reduced** by the double-glazed glass windows?

- I conduction
- II convection
- III radiation

- A** I only
- B** III only
- C** I and II only
- D** II and III only

~ End of Paper ~

Name and Index Number: ()	Class:
--	-----------------------



SENG KANG SECONDARY SCHOOL 2023 END OF YEAR EXAMINATION

PHYSICS (REVISED)

6091/02

Secondary 3 Express

5 October 2023

Paper 2 Theory

1 hour 45 minutes

Candidates answer on the Question Paper.

No Additional Materials are required.

READ THESE INSTRUCTIONS FIRST

Write your index number and name on all the work you hand in.

Write in dark blue or black pen on both sides of the paper.

You may use a soft pencil for any diagrams, graphs or rough working.

Do not use staples, paper clips, highlighters, glue or correction fluid.

Section A

Answer **all** questions in the spaces provided.

Section B

Answer **one** question.

Write your answers in the spaces provided.

Candidates are reminded that **all** quantitative answers should include appropriate units.

The use of an approved scientific calculator is expected, where appropriate.

Candidates are advised to show all their working in a clear and orderly manner, as more marks are awarded for sound use of Physics than for correct answers.

At the end of the examination, fasten all your work securely together.

The number of marks is given in brackets [] at the end of each question or part question.

For Examiner's use	
Section A	/ 70
1	/ 3
2	/ 8
3	/ 7
4	/ 8
5	/ 8
6	/ 6
7	/ 5
8	/ 5
9	/ 10
10	/ 10
Section B	/ 10
11 / 12	/ 10
Total	/ 80
Total %	/ 100

Parent's / Guardian's Signature:

This document consists of **19** printed pages and **1** blank page.

Do not turn over the page until you are told to do so.

Section A (70 marks)

Answer **all** the questions in this section in the spaces provided.

- 1 Fig. 1.1 shows the arm of a crane that is used to lift a heavy box. A 900 N force is applied to one cable and 1200 N on the other cable to lift the heavy box. The angle between the two cables is 70° as shown.

Draw a vector diagram to determine the weight of the box.

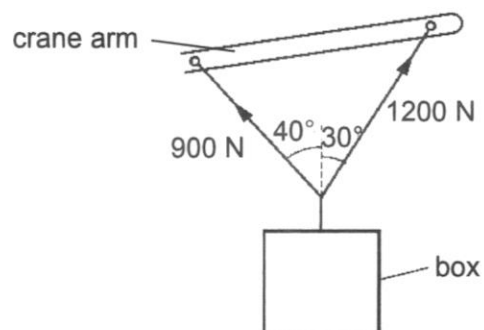

Fig. 1.1 (not to scale)

studykaki.com

studykaki.com

weight of box = [3]

- 2 An astronaut standing on the Moon throws a stone vertically upwards. The stone leaves his hand at time $t = 0$ s. The line in Fig. 2.1 shows how the velocity of the stone varies with time t until $t = 2.0$ s.

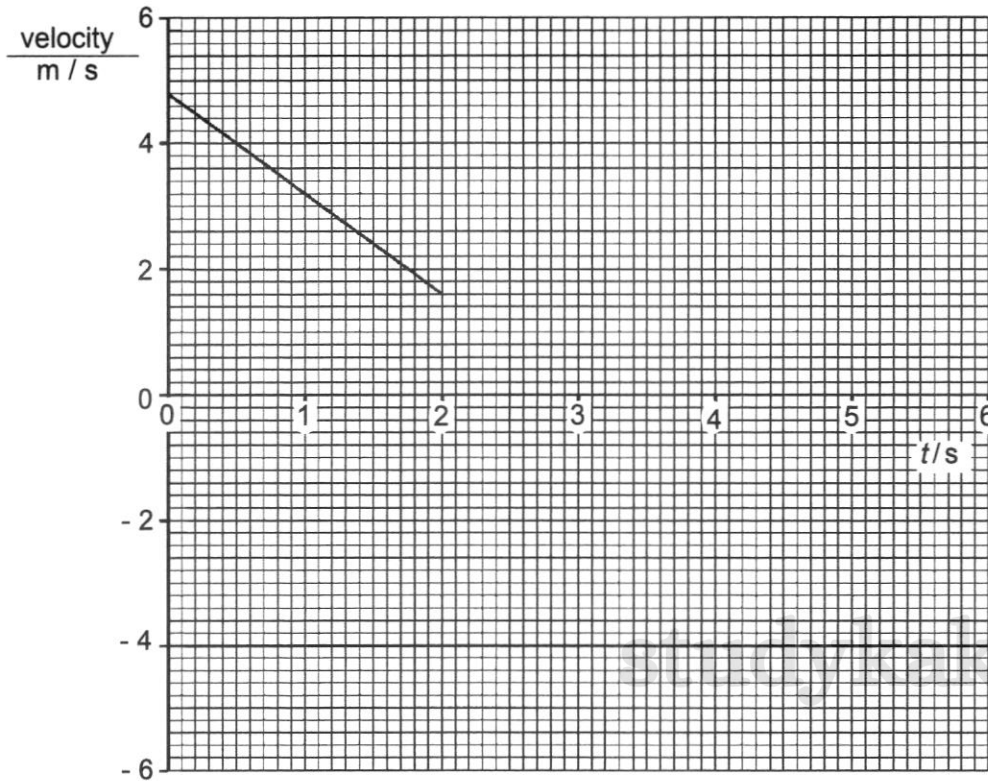

Fig. 2.1

(a) After rising for a period of time, the stone falls vertically downwards. The astronaut catches the stone at $t = 6.0$ s. There is no air resistance on the Moon.

(i) Complete Fig. 2.1 until $t = 6.0$ s. [1]

(ii) State the value of t when the stone is at its highest point.

..... [1]

(iii) Calculate the maximum height achieved by the stone from the point of release.

maximum height = [2]

(b) Use Fig. 2.1 to determine the value of the gravitational acceleration on the Moon.

gravitational acceleration on Moon = [2]

(c) The same stone is thrown vertically upwards on Earth with the same initial velocity.

State two ways in which the velocity-time graph for this throw differs from Fig. 2.1.

1:

2: [2]

studykaki.com

studykaki.com

3 A man starts pulling his 15 kg suitcase across the floor.

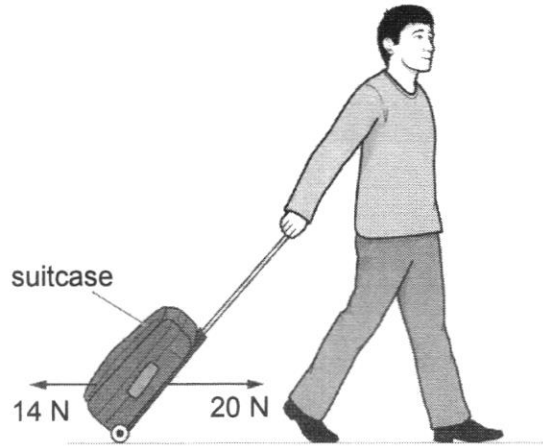

Fig. 3.1

Fig. 3.1 shows the horizontal forces acting on the suitcase.

(a) State the purpose of the wheels on the suitcase.

..... [1]

(b) Calculate

(i) the resultant horizontal force on the suitcase,

resultant force = [1]

(ii) the initial acceleration of the suitcase.

studykaki.com

acceleration = [2]

(c) After a short time, the suitcase moves at a constant speed.

Explain why the suitcase moves at a constant speed even as the man continues to apply the same 20 N force to the right.

.....
 [1]

(d) The suitcase has two wheels. Each wheel has an area of 0.60 cm² touching the ground.

Calculate the pressure exerted by the suitcase on the ground.

pressure on the ground = [2]

- 4 A 10.0 kg uniform plank is placed horizontally on a log of wood, which acts as a pivot. A girl sits on one end of the plank and a boy pushes down on the other end to make the plank balance horizontally. Fig. 4.1 shows the arrangement.

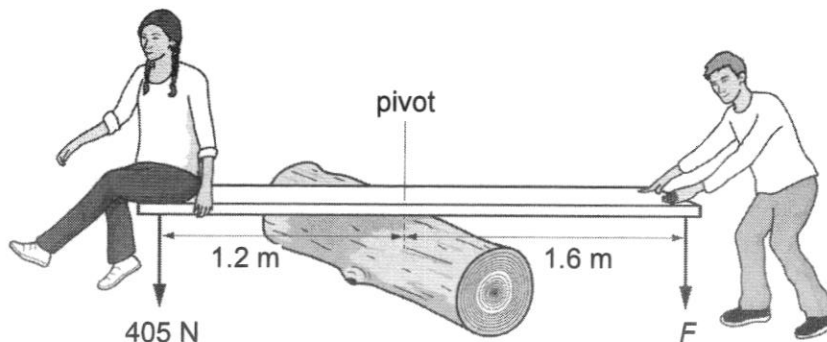

Fig. 4.1

- (a) Calculate the moment of the girl's weight about the pivot.

moment = [2]

- (b) On Fig. 4.1, indicate with an arrow, the position of the weight of the uniform plank. [1]

- (c) The plank balances horizontally when the boy pushes down with a force F at a distance of 1.6 m from the pivot.

- (i) Determine the size of force F .

force F = [3]

- (ii) Using the same setup, suggest two ways that the arrangements can be modified so that the boy needs to apply a smaller force F than the one calculated in (c).

.....

 [2]

- 5 Deep sea divers explore the depths of the ocean using special suits as shown in Fig. 5.1. A deep sea diver is at rest at a depth of 150 m beneath the surface of the sea. The gravitational field strength is 10 N/kg, the atmospheric pressure is 1.0×10^5 Pa and the density of the sea water is 1.0×10^3 kg/m³.

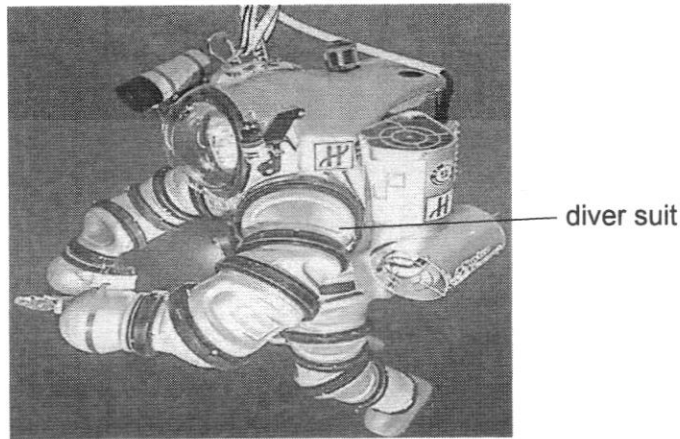

(Source: <http://tecnowebstudio.com/exosuit-novedoso-traje-de-buceo-que-nos-permite-explorar-las-profundidades-del-mar/>)

Fig. 5.1

- (a) Calculate the total pressure acting on the diver at a depth of 150 m.

studykaki.com

total pressure = [3]

- (b) Explain why special suits must be worn by divers when they dive to such great depths.

studykaki.com

.....
 [1]

- (c) Bubbles of air are released by the suits of the divers and the bubbles rise upwards to the top surface of the seawater.

- (i) Explain, in terms of density, why the bubbles rise to the top surface.

.....
 [1]

- (ii) Describe, in terms of pressure, the changes, if any, to the volume of the bubbles as they rise to the top surface of the seawater.

.....
 [1]

- (d) The pressure inside the rigid cylinder containing the oxygen for the diver changes with the surrounding temperature of the water. The temperature of seawater at a depth of 150 m is $-2.0\text{ }^{\circ}\text{C}$.

Describe and explain what happens to the pressure due to the oxygen molecules inside the cylinder during the dive.

.....
.....
..... [2]

studykaki.com

studykaki.com

- 6 The anchor of an old sailing ship has a mass of 400 kg. Six sailors raise the anchor from the seabed by pushing on the handles that turn a large axle. The anchor is on the end of a chain that winds onto the turning axle.

Fig. 6.1 shows the sailors lifting the anchor by pushing the handles in the same direction.

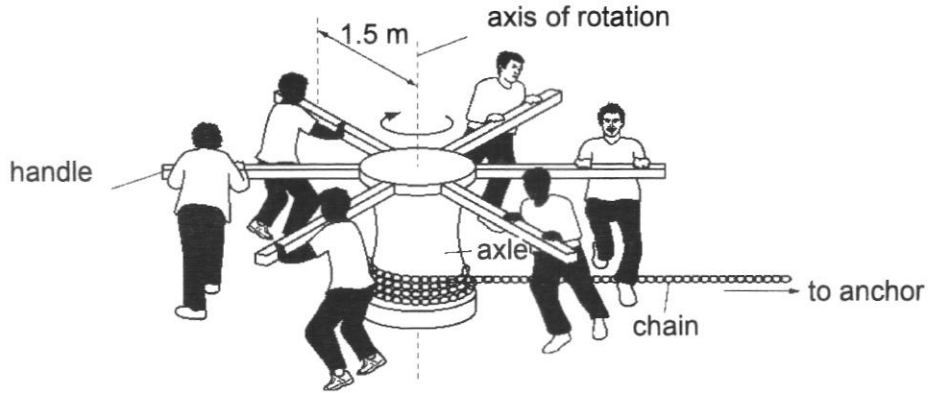

Fig. 6.1

- (a) Each handle is at a distance of 1.5 m from the axis of rotation. The total moment produced by the anchor and chain is 6000 Nm.

Calculate the average force exerted by each of the sailor on the handle of the turning axle.

average force = [3]

- (b) In one complete revolution, the anchor is lifted through a distance of 140 cm.

- (i) Calculate the work done on the anchor in one complete revolution.

work done = [2]

- (ii) Explain whether the actual work done by the sailors to lift the anchor through one complete revolution is more, equal, or less than the answer in (b)(i).

.....
 [1]

7 Fig. 7.1 and Fig. 7.2 show two methods of using renewable sources to generate electrical power.

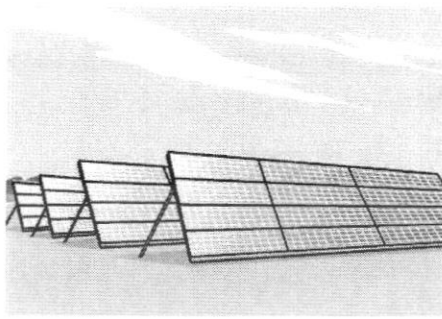

Fig. 7.1

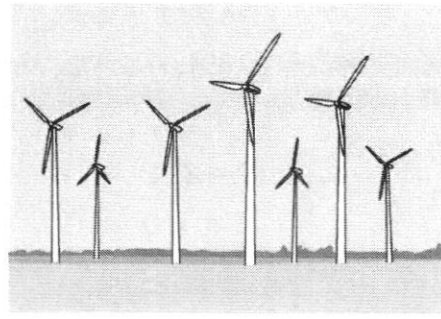

Fig. 7.2

(a) State the energy source used by each method.

Fig. 7.1:

Fig. 7.2: [1]

(b) (i) State two advantages of using the renewable sources in either Fig. 7.1 or Fig. 7.2 for generating electrical power compared to using a fossil fuel power station.

1:

.....

2:

..... [2]

(ii) State one disadvantage of using each renewable sources in Fig. 7.1 and Fig. 7.2 in generating electrical power in Singapore compared to using fossil fuel in our power stations.

Fig. 7.1:

.....

Fig. 7.2:

..... [2]

- 8 A 0.50 kg ball starting from position X, which is 7.5 m above the ground, is projected down an incline with an initial speed of v_0 m/s as shown in Fig. 8.1. When the ball rolls down the incline, 5.0 J of internal energy is transferred away due to friction.

The ball leaves the incline at position Y travelling straight upwards and reaches position Z, which is 13.0 m above the floor, before falling back down.

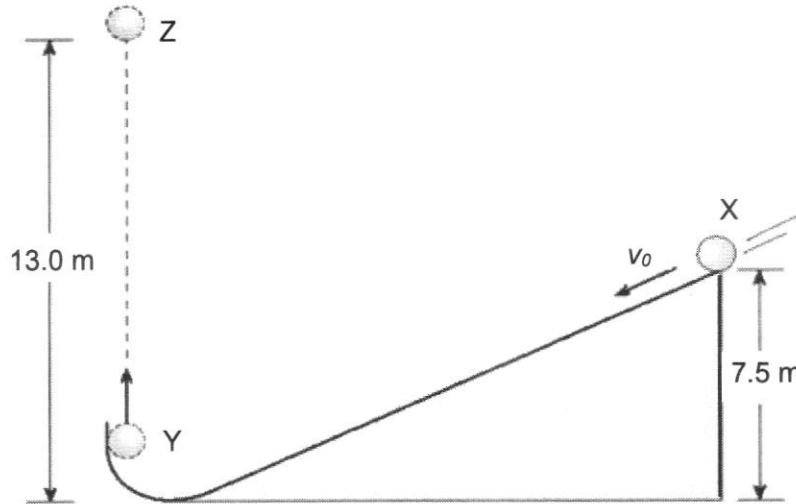

Fig. 8.1

studykaki.com

- (a) What type(s) of energy store(s) does/do the ball possess at position X?

..... [1]

- (b) Calculate the gravitational potential energy of the ball at position Z.

studykaki.com

gravitational potential energy = [1]

- (c) Calculate the initial speed of the ball, v_0 , at position X.

speed, v_0 = [3]

- 9 A student constructs a device for absorbing thermal energy from the Sun. Fig. 9.1 shows the device.

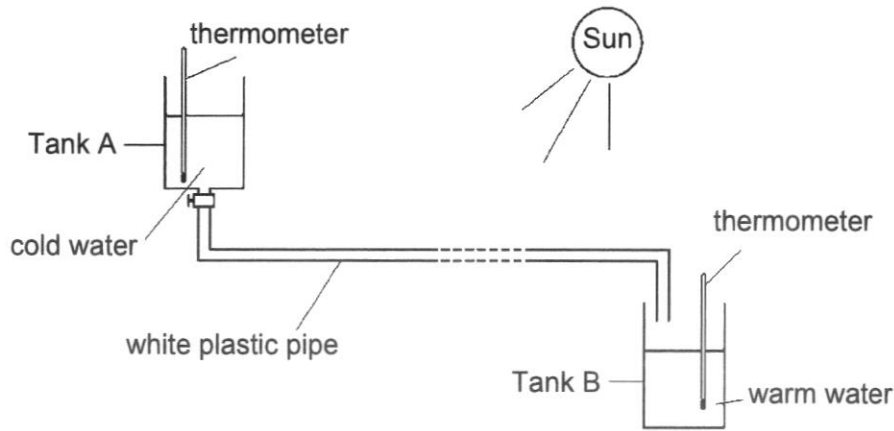
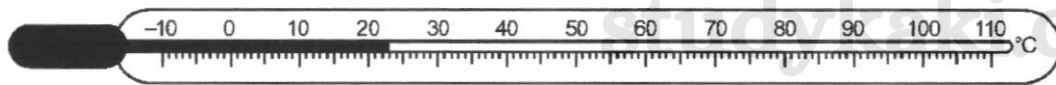

Fig. 9.1

The student places the white plastic pipe in sunlight. The cold water flows slowly from Tank A to Tank B. Energy from the Sun heats the water in the pipe.

Fig. 9.2 shows the temperatures in Tank A and in Tank B.



thermometer in Tank A

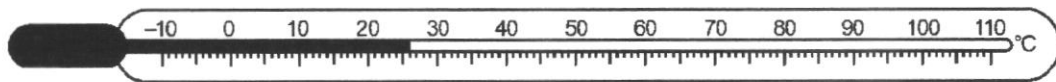

thermometer in Tank B

Fig. 9.2

- (a) Determine the rise in temperature of the water as it passes between Tank A and Tank B.

temperature rise = [1]

- (b) The student wants to increase the thermal energy absorbed by the water in the pipe.

State three improvements she can make to increase the thermal energy absorbed.

- 1:

 2:

 3:
 [3]

(c) Describe the processes that transfer the thermal energy from the Sun to the water inside the pipe.

.....
.....
.....
..... [2]

(d) During one period, 25 kg of water passes through the plastic pipe of the device. The temperature of this water rises from 26 °C to 38 °C. The water absorbs 20% of the energy falling on the device, and the specific heat capacity of water is 4200 J/(kg °C)

Calculate

(i) the energy from the Sun that is absorbed by the water,

studykaki.com

energy absorbed = [2]

(ii) the total energy from the Sun falling on the device during that period.

studykaki.com total energy from the Sun = [2]

- 10 Fig. 10.1 shows an underwater generator that is designed to produce electricity from water currents in the sea.

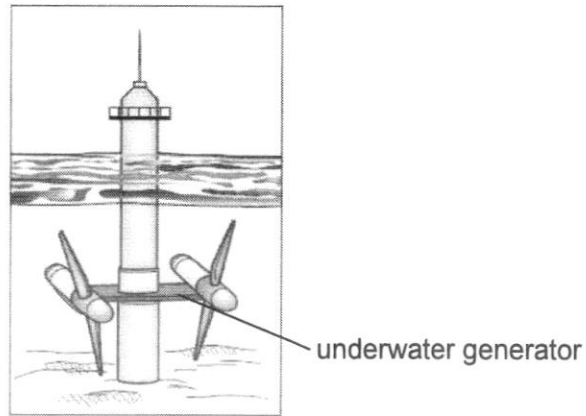

Fig. 10.1

Fig. 10.2 shows how the useful output power of the generator varies with the speed of the water current.

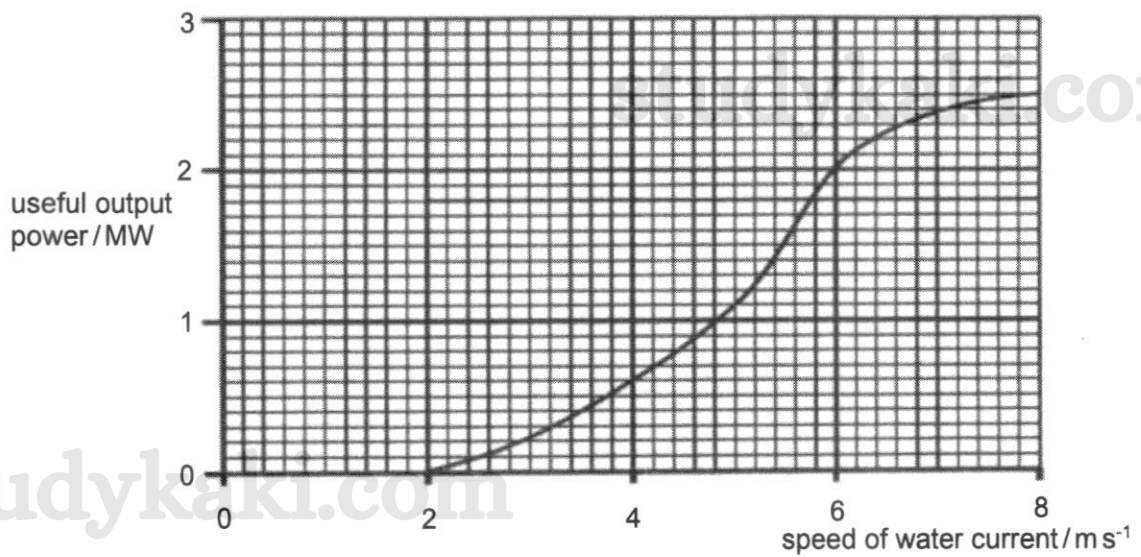

Fig. 10.2

- (a) Using Fig. 10.2, describe how the useful power output varies with the speed of the water current.

.....

.....

.....

.....

..... [3]

- (b) The speed of the water current is recorded at different times of the day, as shown in Table 10.3.

Table 10.3

Time of the day / h	Speed of water current / ms^{-1}
00:00	1.50
02:00	2.50
04:00	4.25
06:00	6.00
08:00	5.50
10:00	4.00
12:00	2.00
14:00	2.30
16:00	4.00
18:00	6.00
20:00	4.80
22:00	2.90

- (i) Using the data in Fig. 10.2 and Table 10.3, describe two disadvantages of using the underwater generator to produce electricity in Singapore.

.....

 [2]

- (ii) Use the data in Fig. 10.2 and Table 10.3 to estimate the total useful energy produced from 18:00 h to 20:00 h. Give your answer in joules.

useful energy = [3]

- (iii) If the efficiency of the underwater generator is 55%, calculate the amount of non-useful energy transferred to other energy stores during the same period.

non-useful energy = [2]

Section B (10 marks)
 Answer **one** question in this section.

- 11 Fig. 11.1 shows a domestic electric heater that is used to heat a room during the winter season. The heater consists of 16 large bricks of mass 7.0 kg each.

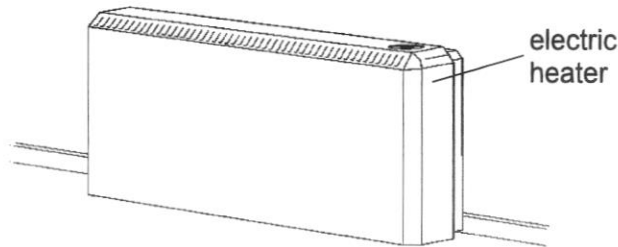

Fig. 11.1

During the night, the bricks are heated from 16 °C to 96 °C. The material of the bricks has a specific heat capacity of 2300 J/(kg °C).

- (a) Calculate the internal energy supplied to the bricks.

studykaki.com

thermal energy supplied = [3]

- (b) During the day, the bricks gradually cool and the stored internal energy is released to the room. After 8.0 hours the bricks have cooled to 16 °C.

Calculate the rate of internal energy release in joule per second.

studykaki.com

rate of internal energy release = [2]

- (c) Describe the process(es) in which the heater heats up the room.

.....

 [3]

(d) The domestic electric heater is located at the floor of the room while the air-conditioner is placed on the wall nearer the top part of a room.

Explain why the air-conditioner is located at the top instead of the floor.

.....
.....
.....
..... [2]

studykaki.com

studykaki.com

- 12 Fig. 12.1 shows a manometer that is used to measure the pressure difference between the inside of a plastic container and the atmosphere outside.

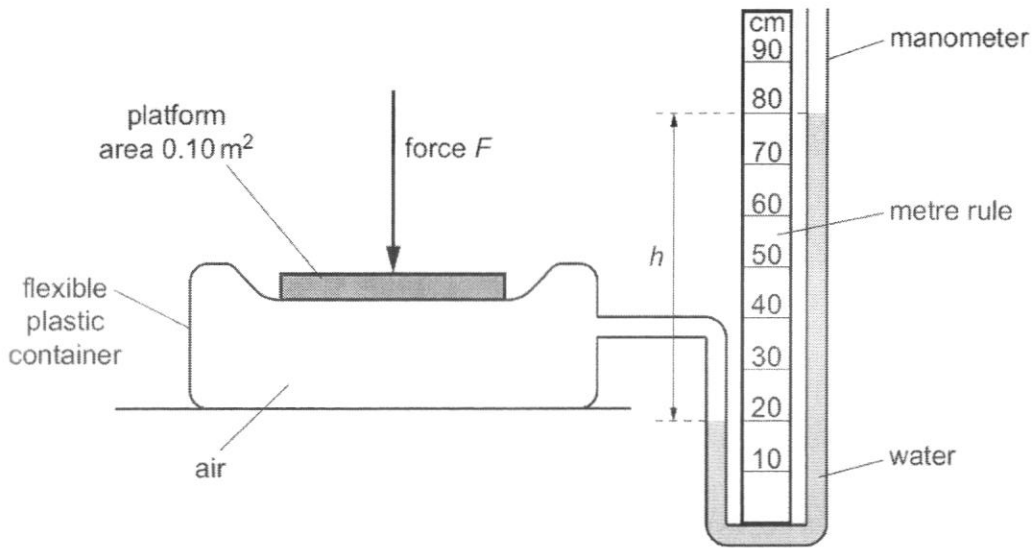

Fig. 12.1

The density of water is 1000 kg/m^3 . The gravitational field strength g is 10 N/kg .

- (a) Define *density*.

..... [1]

- (b) Using Fig. 12.1, determine the pressure difference in Pa as shown by the manometer.

..... pressure = [2]

- (c) State and explain what happens to the distance h in Fig. 12.1 if:

- (i) the manometer tube is wider

.....
 [2]

- (ii) a liquid denser than water is used in the manometer.

.....
 [2]

(d) The pressure difference measured by the manometer is due to the force F .

This force is equal in magnitude to the weight of a student standing on the platform with a cross-sectional area 0.10 m^2 .

Calculate the mass of the student.

mass = [3]

~ End of Paper ~

studykaki.com

studykaki.com

3E 6091 Pure Physics
End of Year Examinations
2023 Marking Scheme

Paper 1

1. C	2. D	3. A	4. A	5. D	6. C	7. B	8. A	9. C	10. C
11. B	12. A	13. B	14. C	15. A	16. C	17. D	18. C	19. D	20. D
21. D	22. A	23. B	24. B	25. C	26. B	27. A	28. A	29. C	30. A
31. A	32. B	33. C	34. D	35. A	36. B	37. B	38. A	39. B	40. C

Paper 2

Section A

- 1 correct construction of parallelogram/triangle (scale: 1 cm : 150 N)
- arrowheads on vectors - M1
 - labelling of vector values - M1
 - resultant force = weight of box = $17.3 \times 100 = 1730 \text{ N}$. - A1
(accept between 1680 to 1780 N)
 - deduction 1m for no scale indicated.
- 2(a) correct straight line extended to $t = 6\text{s}$. - A1
- (a) $t = 3.0 \text{ s}$ - A1 [allow ecf from (i) so any stated value crossing x-axis]
- (a) max. height = $\frac{1}{2} \times 3 \times 4.8$ - M1 [allow ecf]
 $= 7.2 \text{ m}$ - A1
- 2(b) $g = (4.8 - 0)/3$ - M1
 $= 1.6 \text{ m/s}^2$ - A1
- 2(c) 1. Steeper gradient
 2. Shorter time to reach highest point
 3. Curve not a full straight line (due to air resistance) (any 2 of them, 1m each)
- 3(a) Reduce the effect of friction between the suitcase and the ground/opposing the motion. - B1
- 3(b) resultant force = $20 - 14 = 6.0 \text{ N}$ - A1 (must be correct s.f. and unit, else 0m)
- (b) $a = Fr / m = 6/15$ - M1 (allow ecf)
 $= 0.40 \text{ m/s}^2$ - A1 (correct s.f and unit)
- 3(c) The force opposing the motion is equal to the 20 N force of the man/resultant force becomes zero due to friction, and since $Fr = ma$, there is no acceleration and it moves with constant speed. - A1
- 3(d) Pressure = $F / A = (15 \times 10) / (2 \times 0.60)$ - M1
 $= 125 \text{ N/cm}^2$ - A1
- 4(a) moment of girl's weight = 405×1.2 - M1
 $= 486 \text{ N m}$ - A1 (correct unit)
 [Accept 490 N m (2.s.f.)]

- 4(b) correct position and from midpoint (1.4 m) of plank downwards - A1
- 4(c) By the principle of moment, at equilibrium, taking moment about the pivot:
 ACW moment = CW moment
 $486 = (10 \times 10 \times 0.2) + (F \times 1.6)$ - M1M1
 $F = 291 \text{ N}$ - A1 (3sf and correct unit)
- (cii) 1: girl move nearer to pivot
 2: Pull the plank nearer to the boy such that the pivot is further than 1.6 m away from the boy (1m each)
- 5(a) Pressure due to the seawater = $h\rho g = 150 \times 1.0 \times 10^3 \times 10$
 $= 1.5 \times 10^6 \text{ Pa}$ - B1
- Total pressure = $1.5 \times 10^6 + 1.0 \times 10^5$ - M1
 $= 1.6 \times 10^6 \text{ Pa}$ - A1
- 5(b) Pressure at great depth is too high for the human body to withstand, suit protects the diver by providing counter pressure/maintain an internal max. threshold pressure. - A1
- 5(c) The density of the air in the bubble is lower than water and hence, rise to the surface. - A1
- (cii) The volume of the bubble will increase as the pressure acting on the bubble decreases as it rises. - A1
- 5(d) pressure decreases - B1
 as the temperature of the water drops, the average kinetic energy of the oxygen molecules decreases and collides with the walls with lower frequency and force. - A1
- 6(a) force = moment/perpendicular distance = $6000 / 1.5$ - M1
 $= 4000 \text{ N}$ - A1
- Average force per sailor = $4000 / 6$
 $= 667 \text{ N}$ - A1 (correct s.f. and unit)
- 6(b) work done = force x distance = 4000×1.4 - M1
 $= 5600 \text{ J}$ - A1 (correct unit)
- (bii) More, there is also work done to overcome resistance/friction/energy transferred to other stores - A1
- 7(a) Solar, Wind respectively - A1 (both must be correct to earn the mark)
- 7(b) any **two** from (1m each to max. of 2m):
- (renewable sources) are replaceable in a short time
 - no (atmospheric) pollution
 - conserves fossil fuels
 - do not contribute to global warming
- (bii) any **one** for each from (1m to max. of 2m):
 dependent on weather/cloud cover
 supply of energy is intermittent/cannot get during the day

- 8(a) KE and GPE - A1 [both, c.a.o]
- 8(b) $GPE = 0.50 \times 10 \times 13 = 65 \text{ J}$
- 8(c) by conservation of energy,
 $GPE + KE \text{ at } X = 65 + 5 = 70 \text{ J}$ - B1 [seen or implied]
- $\frac{1}{2} (0.50)v_0^2 + (0.50 \times 10 \times 7.5) = 70$ - M1
 $v_0^2 = 130$
 $v_0 = 11.4 \text{ m/s}$ - A1
- 9(a) Rise in temp = $26^\circ\text{C} - 23^\circ\text{C} = 3^\circ\text{C}$ - A1 [c.a.o]
- 9(b) B1 to a max. of 3m for any three from:
- use metal pipe
 - paint black or use black pipe
 - use matt or dull (paint)
 - (place) reflector behind pipe
 - use long(er) pipe
 - use pipe with great(er) surface area
 - slow(er) flow rate
 - (place) glass / (clear) plastic cover over pipe
- 9(c) radiation by electromagnetic waves through space / air (in form of infrared) absorbed by pipe particles - A1
 conduction transfer by vibrational motion between pipe particles and water molecules - A1
- 9(di) Internal energy, $Q = mc\theta = 25 \times 4200 \times (38 - 26)$ - M1
 $= 1.26 \times 10^6 \text{ J}$ or 1.26 MJ - A1
- (dii) Total energy falling from the Sun = $1.26 \times 10^6 \times 5$ - M1 (allow e.c.f)
 $= 6.30 \times 10^6 \text{ J}$ or 6.3 MJ - A1
- 10(a) From 0 to 2 m/s, no useful power output - B1
 From 2 to 6 m/s, useful power output increase at increasing rate from 0 to 2 MW - B1
 From 6 to 8 m/s, useful power output increase at decreasing rate from 2 to 2.5 MW (must give specific values from graph, otherwise no marks) - B1
- 10(bi) not consistent
 not constant supply
 too low useful power produced
 (1m each, max. 2m)
- (bii) Speed at 18:00 to 20:00 = 6.00 m/s
 Useful power output = 2 MW - B1 (seen or implied)
- Useful energy produced = Power x time = $(2 \times 10^6) \times (2 \times 60 \times 60)$ - M1
 $= 1.44 \times 10^{10} \text{ J}$ - A1 (correct s.f. and unit)
- (biii) non-useful power = $2/55 \times 45 = 1.64 \text{ MW}$ - B1
- Non-useful energy = $(1.64 \times 10^6) \times (2 \times 60 \times 60)$
 $= 1.18 \times 10^{10} \text{ J}$ - A1

- 11(a) Internal energy, $Q = m c \theta = (7 \times 16) \times (2300) \times (96 - 16)$ - M1M1
 $= 2.06 \times 10^7 \text{ J or } 20.6 \text{ MJ}$ - A1 (correct s.f. and unit)
- 11(b) Rate = $(2.06 \times 10^7) / (8 \times 60 \times 60)$ - M1 (allow e.c.f.)
 $= 716 \text{ J/s}$ - A1 (correct s.f. and unit)
- 11(c) conduction transfer by vibrational motion between brick particles and air particles - B1
 radiation by electromagnetic waves from bricks through air (in form of infrared) and absorbed by
 air particles - B1
 heated air particles less dense and rise, cooler particles at top denser, sinks, - B1
 repeated cycle creates a convection current that rapidly heats the room - B1
 (in ax. 3m)
- 11(d) air con used to cool the room by taking internal energy from warmer air particles - B1
 since warmer air particles are less dense and rise, while cooler air particles are denser
 and sinks, - B1
 the air con must be placed at the top
- 12(a) amount of mass per unit volume - A1 [c.a.o]
- 12(b) pressure difference = $h\rho g = (0.80 - 0.20) \times 1000 \times 10$ - M1
 $= 6000 \text{ Pa or } 6.0 \text{ kPa}$ - A1
- 12(c) remains the same - B1
 since the same height of water is required to balance the pressure of the left arm - A1
- (cii) shorter - B1
 since liquid pressure is $h\rho g$, when the density ρ is higher, the height required for the same
 pressure will be lower - A1
- 12(d) pressure = $F / A = 6000$
 $F = 6000 \times 0.10$ - M1
 $= 600 \text{ N}$ - A1
- $F = W = mg$
 $m = 600 / 10$
 $= 60 \text{ kg}$ - A1

studykaki.com