

Name:	Index No.:	Class:
-------	------------	--------

PRESBYTERIAN HIGH SCHOOL



MATHEMATICS PAPER ONE

4048/01

11 August 2022

Thursday

2 hours

PRESBYTERIAN HIGH SCHOOL PRESBYTERIAN HIGH SCHOOL PRESBYTERIAN HIGH SCHOOL PRESBYTERIAN HIGH SCHOOL
 PRESBYTERIAN HIGH SCHOOL PRESBYTERIAN HIGH SCHOOL PRESBYTERIAN HIGH SCHOOL PRESBYTERIAN HIGH SCHOOL
 PRESBYTERIAN HIGH SCHOOL PRESBYTERIAN HIGH SCHOOL PRESBYTERIAN HIGH SCHOOL PRESBYTERIAN HIGH SCHOOL
 PRESBYTERIAN HIGH SCHOOL PRESBYTERIAN HIGH SCHOOL PRESBYTERIAN HIGH SCHOOL PRESBYTERIAN HIGH SCHOOL
 PRESBYTERIAN HIGH SCHOOL PRESBYTERIAN HIGH SCHOOL PRESBYTERIAN HIGH SCHOOL PRESBYTERIAN HIGH SCHOOL

SECONDARY FOUR EXPRESS/ FIVE NORMAL PRELIMINARY EXAMINATIONS

**DO NOT OPEN THIS QUESTION PAPER UNTIL YOU ARE TOLD TO DO SO.
READ THESE INSTRUCTIONS FIRST**

Write your name, index number and class on all the spaces provided above.
Write in dark blue or black pen. You may use a soft pencil for any diagrams or graphs.
Do not use staples, paper clips, highlighters, glue or correction fluid.

Answer **all** questions.

If working is needed for any question, it must be shown with the answer.

Omission of essential working will result in loss of marks.

The use of an approved scientific calculator is expected, where appropriate.

If the degree of accuracy is not specified in the question, and if the answer is not exact, give the answer to three significant figures. Give answers in degrees to one decimal place.

For π , use either your calculator value or 3.142, unless the question requires the answer in terms of π .

The number of marks is given in brackets [] at the end of each question or part question.

The total number of marks for this paper is 80.

Note that all the diagrams in this paper are not drawn to scale.

<i>For Examiner's Use</i>				
Category	Accuracy	Symbols	Others	Marks Deducted
Question No.				

Total Marks
80

This question paper consists of **19** printed pages (including this cover page) and **1** blank page.

Mathematical Formulae*Compound Interest*

$$\text{Total amount} = P \left(1 + \frac{r}{100} \right)^n$$

Mensuration

$$\text{Curved surface area of a cone} = \pi r l$$

$$\text{Surface area of a sphere} = 4\pi r^2$$

$$\text{Volume of a cone} = \frac{1}{3} \pi r^2 h$$

$$\text{Volume of a sphere} = \frac{4}{3} \pi r^3$$

$$\text{Area of triangle ABC} = \frac{1}{2} ab \sin C$$

$$\text{Arc length} = r\theta, \text{ where } \theta \text{ is in radians}$$

$$\text{Sector area} = \frac{1}{2} r^2 \theta, \text{ where } \theta \text{ is in radians}$$

Trigonometry

$$\frac{a}{\sin A} = \frac{b}{\sin B} = \frac{c}{\sin C}$$

$$a^2 = b^2 + c^2 - 2bc \cos A$$

Statistics

$$\text{Mean} = \frac{\sum fx}{\sum f}$$

$$\text{Standard deviation} = \sqrt{\frac{\sum fx^2}{\sum f} - \left(\frac{\sum fx}{\sum f} \right)^2}$$

Answer **all** the questions.

1 Simplify $7y - 5x - 2(y + 3x)$.

Answer [2]

2 Factorise completely $2x^2 - 50$.

Answer [2]

3 (a) Write down the fraction(s) that is/are equivalent to $\frac{a}{b}$.

$$\frac{b}{a} \quad \frac{1}{b} \quad \frac{a+1}{b+1} \quad \frac{a^2}{b^2}$$

Answer [1]

(b) Given that $p = 3q$ and $2q = r$, write down the ratio of $p : q : r$.

Answer : : [1]

- 4 The line graph below in an advertisement shows the brightness of teeth after using Charcoal Brand toothpaste.

Brightness of teeth after using Charcoal Brand toothpaste

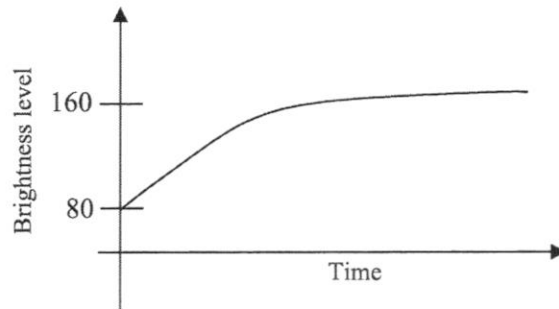

The advertisement claims that

'Your teeth will turn doubly bright after using Charcoal Brand toothpaste for a short time.'

Do you agree with the claim? Give **two** reasons to support your answer.

Answer

.....

..... [2]

5 Solve the equation $\frac{3x-5}{4} - \frac{x}{6} = 3$.

Answer $x = \dots\dots\dots$ [2]

- 6 A number has exactly eight factors. Two of the factors are 18 and 27. List all the factors of the number.

Answer

- 7 Alicia has 504 one-centimetre cubes.
She arranges all the cubes into a cuboid.
If the area of the base of the cuboid is a perfect square, find the smallest possible height of the cuboid.

Answercm [2]

- 8 (a) Calculate $\frac{11.9^3}{6.43 - 2.51}$.
Write down the first five digits of your answer.

Answer [1]

- (b) Write your answer to **part (a)** correct to 2 significant figures.

Answer [1]

- 9 The following stem and leaf diagram shows the height, in cm, of 10 Secondary Four students.

Stem	Leaf
14	8 9
15	4 9
16	0 2 3
17	0 1 1

Key: 14 | 6 means 146 cm

For the heights, find

- (a) the range,

Answercm [1]

- (b) the median.

Answercm [1]

10 Given that $81^n \div 9 = 3^{\frac{1}{2}}$, find the value of n .

Answer $n = \dots\dots\dots$ [3]

11 Mrs. Mok deposited $\$P$ in GAIN Bank for 3 years.
GAIN Bank pays a compound interest of 1.86% per annum to its depositors.
At the end of 3 years, Mrs. Mok withdrew a total of $\$264\,211.08$. How much interests did Mrs. Mok earn? Give your answer to the nearest cent.

Answer $\$ \dots\dots\dots$ [3]

- 12 (a) A range of values of x is represented on the number line below.

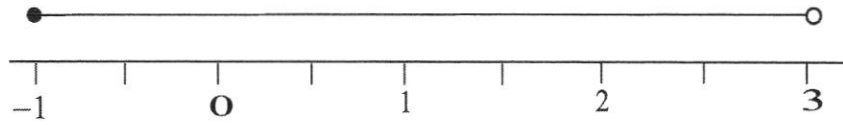

Write down inequalities that represent this range of values for x .

Answer [1]

- (b) Solve the inequality $\frac{x+3}{2} > 5-4x$.

Answer [2]

13 $\xi = \{\text{integers } x : 2 \leq x \leq 12\}$

The Venn diagram shows the elements of ξ and three sets A , B and C .

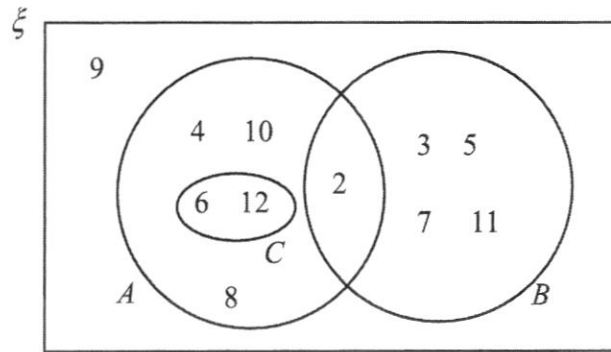

Use one of the notations below to complete each statement.

\subset \supset \in \notin \subseteq

(a) $9 \dots\dots\dots (A \cup B)'$ [1]

(b) $\{3, 5\} \dots\dots\dots A$ [1]

(c) $B \cap C = \dots\dots\dots$ [1]

14 y is inversely proportional to x . It is given that $y = 4$ when $x = 4$.

(a) Find an equation connecting x and y .

Answer [1]

(b) Find the percentage change in y when x is increased to 200%.

Answer% [2]

15 In the diagram, ABC is a triangle in which $AB = AC$.

The side AC is produced to P such that $CP = AC$ and CB is produced to Q such that $QB = BC$.

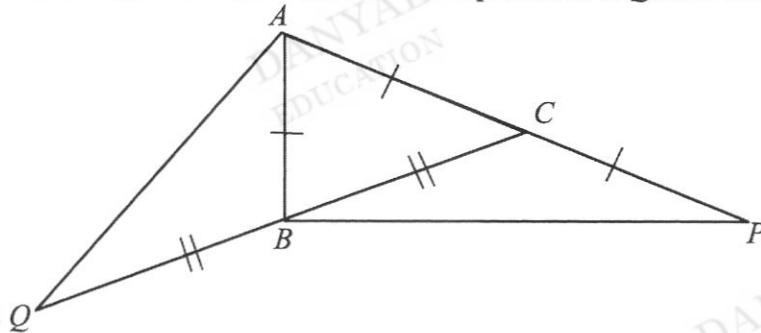

Show that triangles AQB and PBC are congruent.

Answer

[3]

16 (a) Convert 720 m/h into m/s.

Answerm/s [1]

(b) A map has a scale of 1 : 500 000.

The bullet train, “Shinkansen”, operates on Japan's high-speed railway network at a speed of 320 km/h. It takes 1 hour and 30 minutes to travel from Tokyo to Fukushima.

Find the distance of the Shinkansen track, in cm, on the map between Tokyo and Fukushima.

Answercm [3]

- 17 (a) Express $x^2 - 4x + 5$ in the form $(x - p)^2 + q$.

Answer [2]

- (b) Sketch the graph of $y = x^2 - 4x + 5$ on the axes below.
Indicate clearly on the graph, its turning point and intersection with the y-axis.

Answer

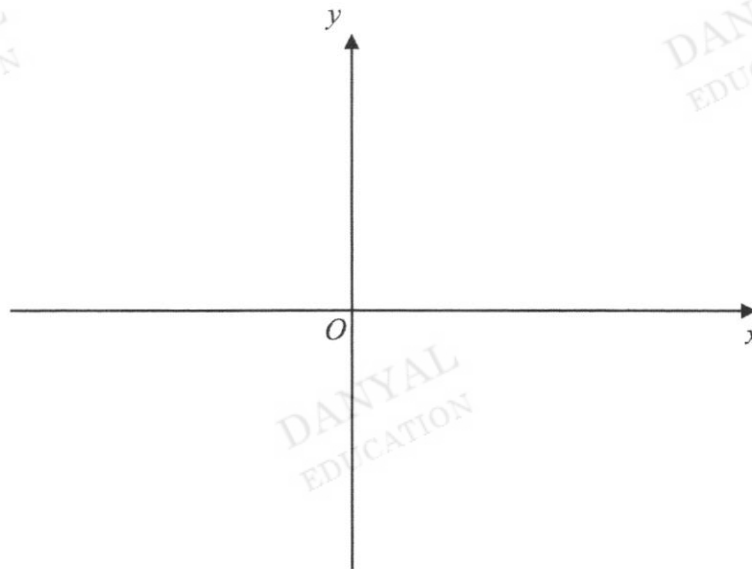

[2]

18 The position vector of point J is $\begin{pmatrix} 2 \\ 3 \end{pmatrix}$.

The point K is the result of translation of the point J by $\begin{pmatrix} 6 \\ -4 \end{pmatrix}$.

(a) Write down the coordinates of point K .

Answer [1]

(b) Find the magnitude of \overrightarrow{JK} .

Answer [2]

(c) Given that $\overrightarrow{KN} = \overrightarrow{JK}$, find the coordinates of point N .

Answer [1]

DANYAL
EDUCATION

DANYAL
EDUCATION

DANYAL
EDUCATION

DANYAL
EDUCATION

DANYAL
EDUCATION

- 19 (a) Simplify $(x^6)^{-\frac{2}{3}}$ and leave your answer in positive index notation.

Answer [1]

- (b) Solve these simultaneous equations.

$$6x - 2y = 19$$

$$8x + 5y = 10$$

Answer $x =$
 $y =$ [3]

- 20 A construction site is in the shape of a quadrilateral $PQRS$, such that $QR = 11$ cm, $\angle PQR = 85^\circ$ and $PS = RS = 9.8$ cm. PQ has been drawn for you.
- (a) Construct the quadrilateral $PRQS$. [2]

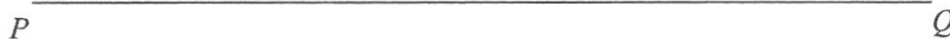

- (b) Construct the perpendicular bisector of PQ . [1]
- (c) Construct the bisector of angle PSR . [1]
- (d) The letter ' W ' is at the intersection of the point where it is equidistant from P and Q , and equidistant from the sides of PS and RS . Mark and label the letter ' W ' to indicate its position. [1]

21 The ages of 10 children are given below.

9, 7, 8, 9, 6, x , 4, 10, 7, $x+2$

(a) If the mean age is 8 years, show that $x = 9$.

Answer

[1]

(b) Calculate the standard deviation.

Answer [2]

(c) Another 3 children, each of them 8 years in age, were added to the above data set. Without any re-calculations, describe clearly how, the mean and the standard deviation will be affected, if any.

Answer

[2]

22 The diagram below shows three points $P(-4, 2)$, $Q(2, 10)$ and $R(-4, -5)$.

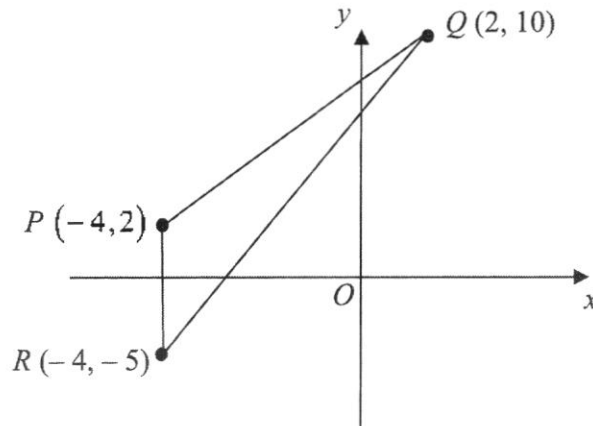

(a) Find the length of PQ .

Answerunits [1]

(b) Find the exact value of $\cos \angle QPR$.

Answer [1]

(c) Find the area of triangle PQR .

Answersq. units [1]

(d) The line $mx + 10y + 5 = 0$ has the same gradient as QR .
Find the value of m .

Answer $m =$ [3]

- 23 The diagram shows the speed-time graph of two objects, *A* and *B*, for the first 12 seconds of their journey. Both objects started at the same point and moved in the same direction.

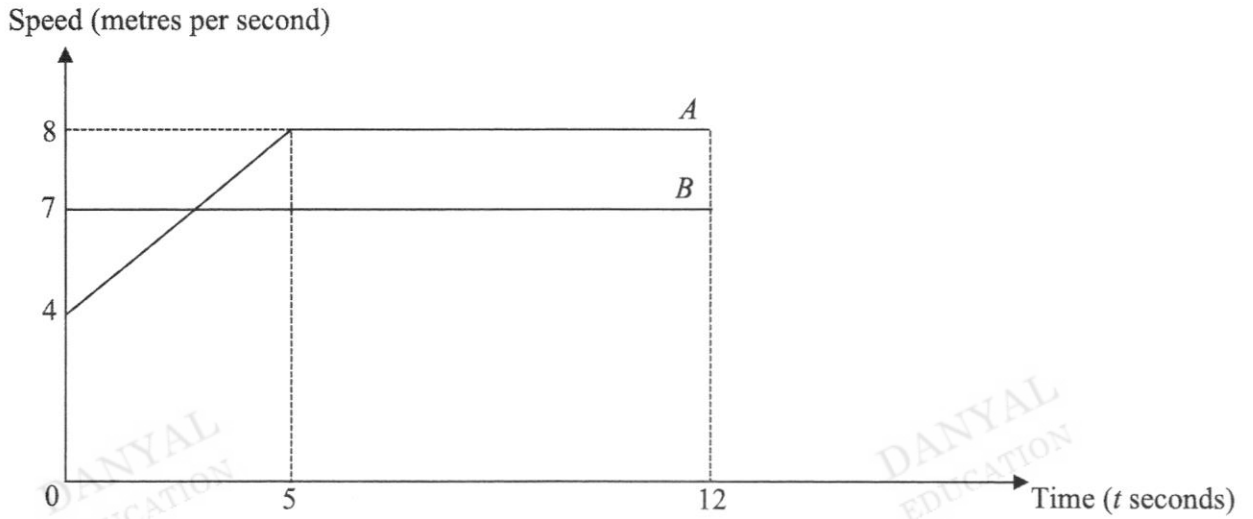

- (a) Find the speed of object *A* at $t = 2.5$.

Answerm/s [1]

- (b) Determine whether object *A* has overtaken object *B* at $t = 5$.
Explain your answer.

Answer

[2]

- (c) Both objects slowed down at the same rate after 12 seconds.
Object *B* came to rest after a further 3.5 seconds.
Calculate the time taken for object *A* to come to rest.

DANYAL
EDUCATION

DANYAL
EDUCATION

DANYAL
EDUCATION

Answerseconds [3]

DANYAL
EDUCATION

DANYAL
EDUCATION

- 24 A picture frame measures 28 cm by 20 cm. A painted picture of area 300 cm^2 is placed on the frame with a border of uniform width of x cm on all four sides.

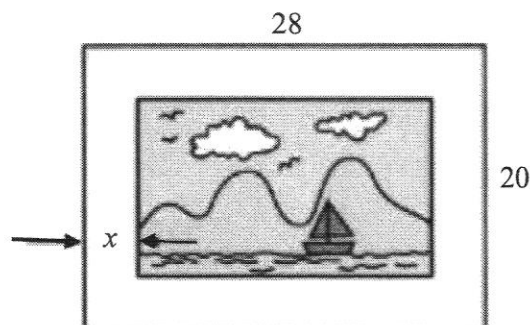

- (a) Form an equation in x and show that $x^2 - 24x + 65 = 0$.

Answer

DANYAL
EDUCATION

DANYAL
EDUCATION

DANYAL
EDUCATION

[3]

- (b) Hence, find the width of the border. Give your answer to 2 decimal places.

DANYAL
EDUCATION

DANYAL
EDUCATION

Answercm [3]

END OF PAPER

Name:	Register Number:	Class:
-------	------------------	--------

PRESBYTERIAN HIGH SCHOOL



MATHEMATICS PAPER TWO

4048/02

15 August 2022

Monday

2 hours 30 minutes

PRESBYTERIAN HIGH SCHOOL PRESBYTERIAN HIGH SCHOOL PRESBYTERIAN HIGH SCHOOL PRESBYTERIAN HIGH SCHOOL
 PRESBYTERIAN HIGH SCHOOL PRESBYTERIAN HIGH SCHOOL PRESBYTERIAN HIGH SCHOOL PRESBYTERIAN HIGH SCHOOL
 PRESBYTERIAN HIGH SCHOOL PRESBYTERIAN HIGH SCHOOL PRESBYTERIAN HIGH SCHOOL PRESBYTERIAN HIGH SCHOOL
 PRESBYTERIAN HIGH SCHOOL PRESBYTERIAN HIGH SCHOOL PRESBYTERIAN HIGH SCHOOL PRESBYTERIAN HIGH SCHOOL
 PRESBYTERIAN HIGH SCHOOL PRESBYTERIAN HIGH SCHOOL PRESBYTERIAN HIGH SCHOOL PRESBYTERIAN HIGH SCHOOL

SECONDARY FOUR EXPRESS / FIVE NORMAL PRELIMINARY EXAMINATION

DO NOT OPEN THIS QUESTION PAPER UNTIL YOU ARE TOLD TO DO SO.

INSTRUCTIONS TO CANDIDATES

Write your name, index number and class on all the spaces provided above.
 Write in dark blue or black pen. You may use a soft pencil for any diagrams or graphs.
 Do not use staples, paper clips, highlighters, glue or correction fluid.

Answer **all** questions.

If working is needed for any question, it must be shown with the answer.

Omission of essential working will result in loss of marks.

The use of an approved scientific calculator is expected, where appropriate.

If the degree of accuracy is not specified in the question, and if the answer is not exact, give the answer to three significant figures. Give answers in degrees to one decimal place.

For π , use either your calculator value or 3.142, unless the question requires the answer in terms of π .

The number of marks is given in brackets [] at the end of each question or part question.

The total number of marks for this paper is 100.

Note that all the diagrams in this paper are not drawn to scale.

For Examiner's Use											
Qn	1	2	3	4	5	6	7	8	9	10	Marks Deducted
Marks											

Total Marks
100

Category	Accuracy	Symbols	Others
Question			

This question paper consists of **25** printed pages (including this cover page) and **1** blank page.

Mathematical Formulae*Compound Interest*

$$\text{Total amount} = P \left(1 + \frac{r}{100} \right)^n$$

Mensuration

$$\text{Curved surface area of a cone} = \pi r l$$

$$\text{Surface area of a sphere} = 4\pi r^2$$

$$\text{Volume of a cone} = \frac{1}{3} \pi r^2 h$$

$$\text{Volume of a sphere} = \frac{4}{3} \pi r^3$$

$$\text{Area of triangle } ABC = \frac{1}{2} ab \sin C$$

$$\text{Arc length} = r\theta, \text{ where } \theta \text{ is in radians}$$

$$\text{Sector area} = \frac{1}{2} r^2 \theta, \text{ where } \theta \text{ is in radians}$$

Trigonometry

$$\frac{a}{\sin A} = \frac{b}{\sin B} = \frac{c}{\sin C}$$

$$a^2 = b^2 + c^2 - 2bc \cos A$$

Statistics

$$\text{Mean} = \frac{\sum fx}{\sum f}$$

$$\text{Standard deviation} = \sqrt{\frac{\sum fx^2}{\sum f} - \left(\frac{\sum fx}{\sum f} \right)^2}$$

1 (a) It is given that $V = \frac{2\pi}{3}(a-b)$.

(i) Evaluate V when $a = 2.8$ and $b = 1.7$.

Answer $V = \dots\dots\dots$ [1]

(ii) Express b in terms of V , π and a .

(b) Simplify $\frac{x}{10y} \div \frac{4xy^2}{5}$.

Answer $\dots\dots\dots$ [2]

Answer $\dots\dots\dots$ [2]

(c) (i) Expand $(2p - q)^2$.

Answer [1]

(ii) Given that $2p - q = 7$ and $4p^2 + q^2 = 63$, without solving for p and q , find the value of pq .

Answer $pq =$ [2]

- 2 (a) The cumulative frequency curve illustrates the marks scored, out of 100, by 200 students for a Mathematics Test.

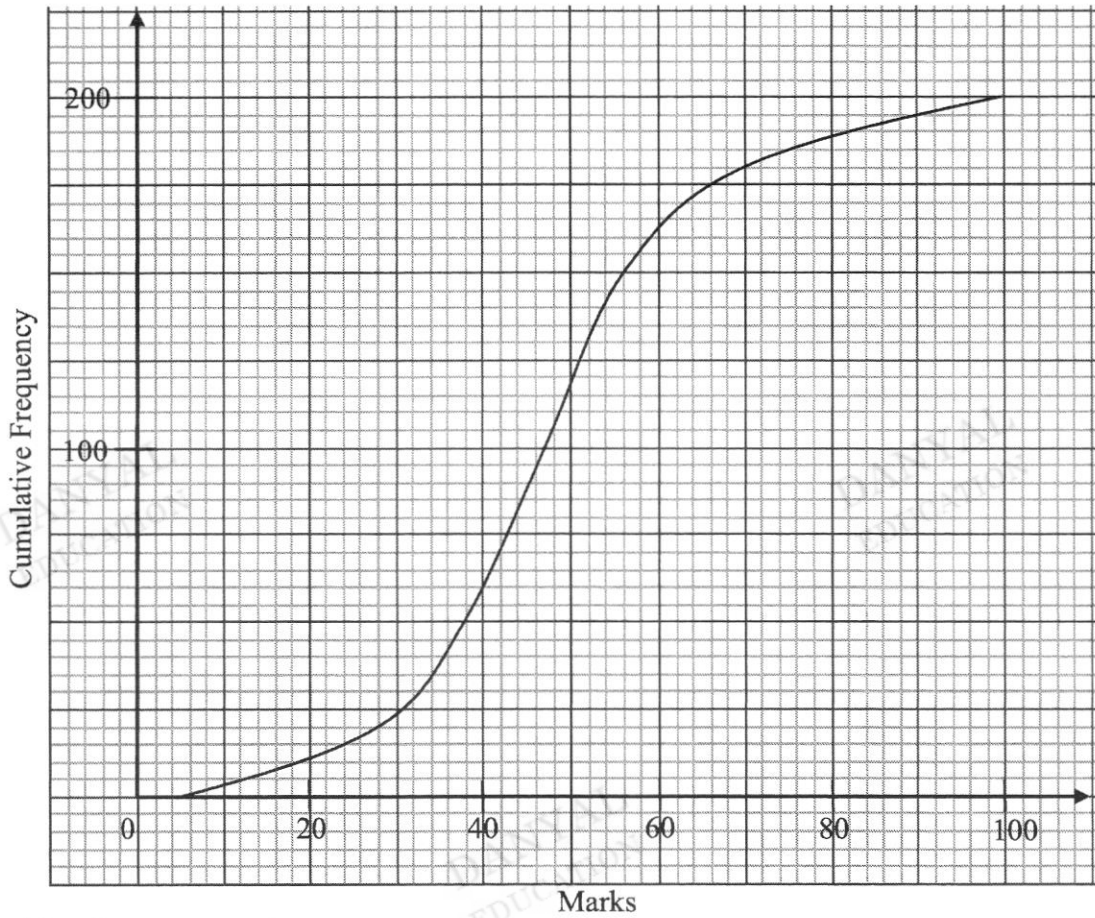

Use the curve to estimate

- (i) the median marks scored,

Answermarks [1]

- (ii) the interquartile range of the marks scored,

Answermarks [2]

- (iii) the number of students who scored at least 66 marks.

Answer [1]

- (b) 20 plants were selected at random and the number of flowers bloomed on each plant were recorded in the table below.

Number of flowers	1	2	3	4
Number of plants	1	10	6	3

- (i) One of the plants is selected at random.
Find the probability that it has 3 flowers.

Answer [1]

- (ii) Two of the plants are selected at random, one after another.
Find, as a fraction in its simplest form, the probability that
 - (a) one of the plants had 1 flower, and the other plant had 2 flowers,

Answer [2]

- (b) both plants had the same number of flowers.

Answer [2]

- 3 (a) The energy consumption of households in Singapore for the year 2019, in kilo tonnes of oil equivalent (ktoe), is 747.2.

Source: <https://www.statista.com/statistics/973038/singapore-household-related-energy-consumption/>

The International Energy Agency defines one tonne of oil equivalent (toe) to be:

1 tonne of oil equivalent (toe) = 11 630 kilowatt hours (kWh)

- (i) Calculate the total amount of energy consumed by households in kWh.
Give your answer in standard form correct to 3 significant figures.

AnswerkWh [2]

- (ii) From 2015 to 2019, the energy consumption of households has increased by 6%.
Calculate the energy consumption of households in 2015.
Give your answer to the nearest ktoe.

Answerktoe [2]

- (b) Andrea and Bella are two sale promoters who work at a Beauty Pop-up Store. The table below shows the number of beauty products each of them sold in the month of July.

	Eye Cream	Face Serum	Lip Balm
Andrea	21	28	10
Bella	27	20	8

- (i) Represent the above information in a 2×3 matrix, **M**.

Answer $\mathbf{M} = \begin{pmatrix} & & \end{pmatrix}$ [1]

- (ii) The commission for each eye cream, face serum and lip balm sold is \$1.20, \$1.50 and \$1.00 respectively. Represent the commission in a 3×1 column matrix **F**.

Answer $\mathbf{F} =$ [1]

- (iii) Evaluate the matrix $\mathbf{N} = \mathbf{MF}$.

Answer $\mathbf{N} =$ [2]

- (iv) State what each element of **N** represent.

Answer

[1]

- (v) If the commission for each eye cream sold remains the same, while the commission for each face serum sold is reduced by 6% and the commission for each lip balm is increased by 10%, write down a matrix **Q** such that **QF** represents the new amount of commission for each of the three beauty products.

Answer $\mathbf{Q} =$ [1]

- 4 In the diagram below, O is the centre of the circle passing through A, B, C and D . AD is the diameter of the circle, and AT and BT are tangents to the circle. Angle $ACB = 24^\circ$ and angle $OBC = 66^\circ$.

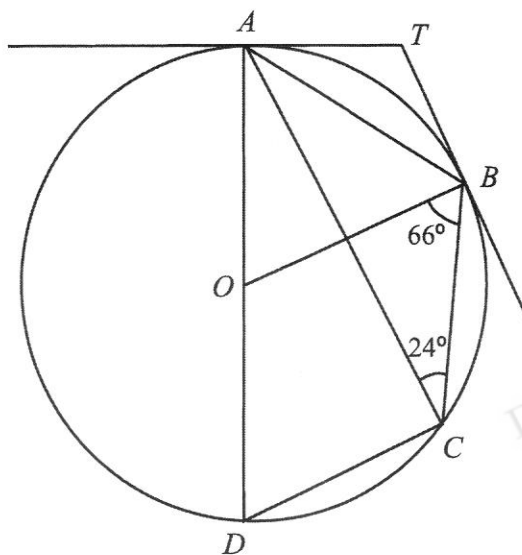

- (a) Find angle AOB .
Give a reason for each step of your working.

Answer Angle $AOB = \dots\dots\dots^\circ$ [2]

- (b) Find angle DAB .
Give a reason for each step of your working.

Answer Angle $DAB = \dots\dots\dots^\circ$ [2]

- (c) Find angle ATB .
Give a reason for each step of your working.

Answer Angle $ATB = \dots\dots\dots^\circ$ [2]

- (d) Find angle ADC .
Give a reason for each step of your working.

Answer Angle $ADC = \dots\dots\dots^\circ$ [2]

- (e) Show that $OBCD$ is a trapezium.

Answer

[2]

- 5 (a) (i) The first four terms of a sequence are 1, 4, 7 and 10.
Express the n th term of this sequence in terms of n .

Answer [1]

Consider another sequence of numbers given below.

$$v_1 = 2^2 - 1$$

$$v_2 = 2^3 - 4$$

$$v_3 = 2^4 - 7$$

$$v_4 = 2^5 - 10$$

.

.

.

- (ii) Write down an expression for v_5 .

Answer [1]

- (iii) Write down, without simplifying, an expression in terms of n , for v_n of this sequence.

Answer [1]

- (iv) Show that $v_{11} = 4065$.

Answer

[1]

- (v) Hence or otherwise, determine the smallest value of n such that $v_n > 65000$.

Answer $n =$ [1]

- (b) (i) Four of the interior angles of a hexagon are each 105° .
One of the remaining interior angles is three times larger than the other interior angle.
Find the size of the smaller interior angle.

DANYAL
EDUCATION

DANYAL
EDUCATION

DANYAL
EDUCATION

Answer $^\circ$ [3]

- (ii) Given that an n -sided regular polygon has an exterior angle of 24° , find the number of sides of this polygon.

DANYAL
EDUCATION

DANYAL
EDUCATION

Answersides [2]

- 6 X, Y and Z are points on horizontal ground such that Z is due east of X .
 It is also given that $XY = 36$ m, $XZ = 82$ m and angle $YXZ = 75^\circ$.

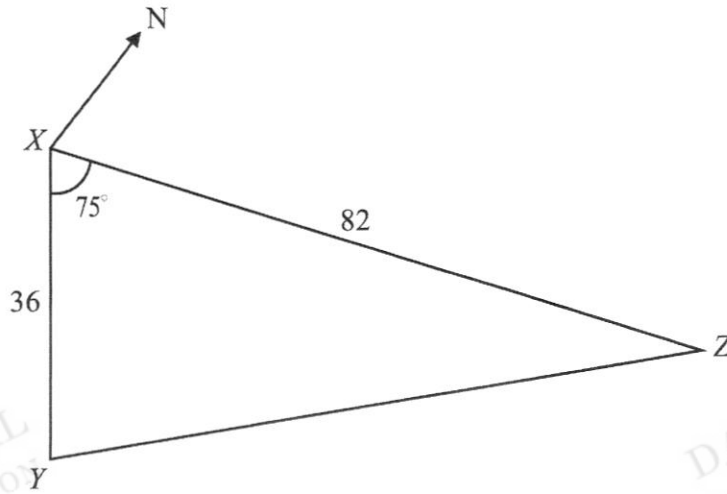

Calculate

- (a) YZ ,

Answerm [3]

- (b) the bearing of Y from Z ,

Answer° [3]

(c) the shortest distance from X to YZ .

Answerm [2]

T is the top of a vertical pole erected at X .

The greatest angle of elevation of T when viewed along YZ is 10° .

(d) Find the height of the pole TX .

Answerm [2]

7 In the diagram below, $QR = 3QT$ and $XP = 3TX$. S is the midpoint of PR . $\vec{QT} = \mathbf{m}$ and $\vec{RS} = \mathbf{n}$.

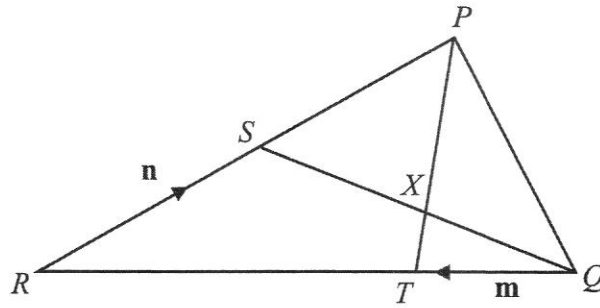

(a) Express in terms of \mathbf{m} and \mathbf{n} , as simply as possible,

(i) \vec{QS} ,

Answer [2]

(ii) \vec{TP} .

Answer [2]

(b) Show that $\vec{QX} = \frac{3}{2}\mathbf{m} + \frac{1}{2}\mathbf{n}$.

Answer

[3]

(c) Calculate the value of

(i) $\frac{QX}{QS}$,

Answer [1]

(ii) $\frac{\text{area of triangle } PQX}{\text{area of triangle } PQT}$,

Answer [1]

(iii) $\frac{\text{area of triangle } PSX}{\text{area of triangle } QXT}$.

Answer [1]

- 8 The diagram below shows the major segment XZY , of circle centre O , which is the cross-section of a 250 m long tunnel and track.

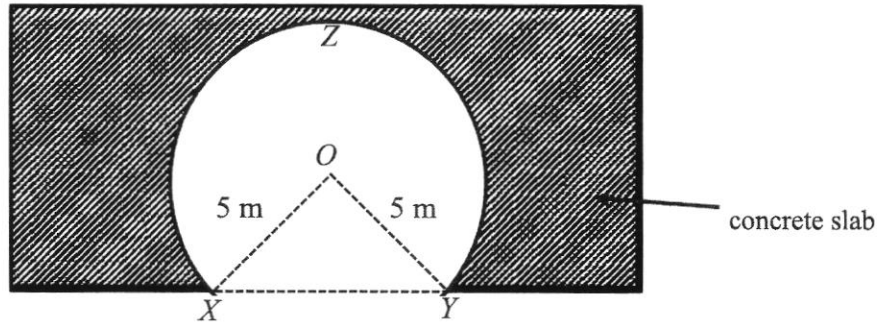

It is given that $OX = OY = 5$ m and the perimeter of $OXZYO$ is 32 m.

- (a) Show that the reflex angle XOY is 4.4 radians.

Answer

[2]

- (b) Find the total internal surface area of the tunnel and its track.

Answerm² [4]

- (c) The major segment of circle XYZ , can also be represented as the uniform cross-section of a circular container, **not filled** with sand sediment, as shown below.

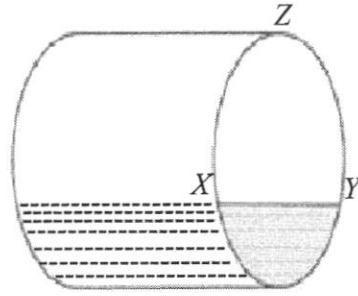

The container is 8 m long.

Calculate the volume of the container which is **not filled** with sand sediment.

DANYAL
EDUCATION

DANYAL
EDUCATION

DANYAL
EDUCATION

DANYAL
EDUCATION

DANYAL
EDUCATION

Answerm³ [4]

- 9 Arnold bought a newborn Labrador Retriever. He recorded the mass of the puppy every Sunday morning. The table below shows some of the values captured, except when $t = 2$.

Age of puppy (t weeks)	0	1	2	3	4	5	6	7
Mass (m kg)	0.3	0.5		1.4	2.0	3.9	6.4	10.7

- (a) On the grid, plot the points given in the table for $0 \leq t \leq 7$ and join them with a smooth curve.

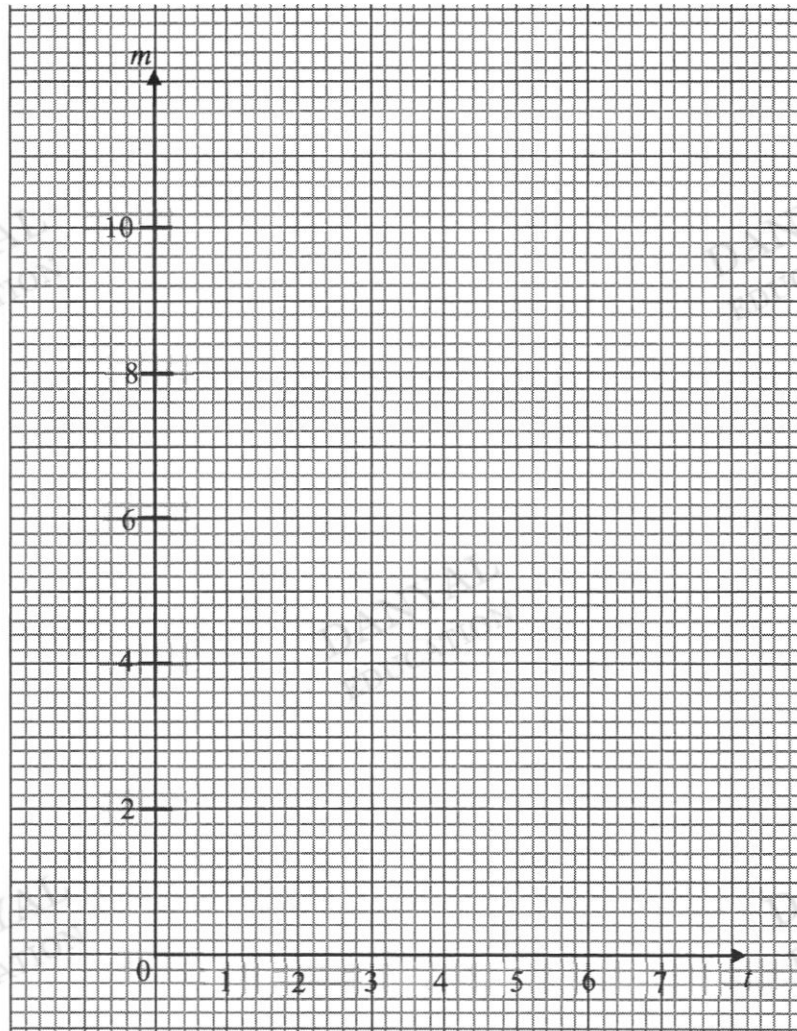

[3]

- (b) Arnold had forgotten to measure the puppy's mass in the second week. Use your graph to estimate the mass of the puppy in the second week.

Answerkg [1]

- (c) Use your graph to estimate the age of the puppy when its mass is 4.5 kg.

Answerweeks [1]

(d) (i) By drawing a suitable tangent, find the gradient of the curve at $t = 5$.

Answer [2]

(ii) What does this gradient represent?

Answer

[1]

(e) The mass of the Labrador Retriever may be estimated by the function $m = ab^t$, where a and b are constants. Suggest appropriate values of a and of b .

Answer $a = \dots\dots\dots$, $b = \dots\dots\dots$ [2]

10 Christy owns a café and the floor plan is shown below.

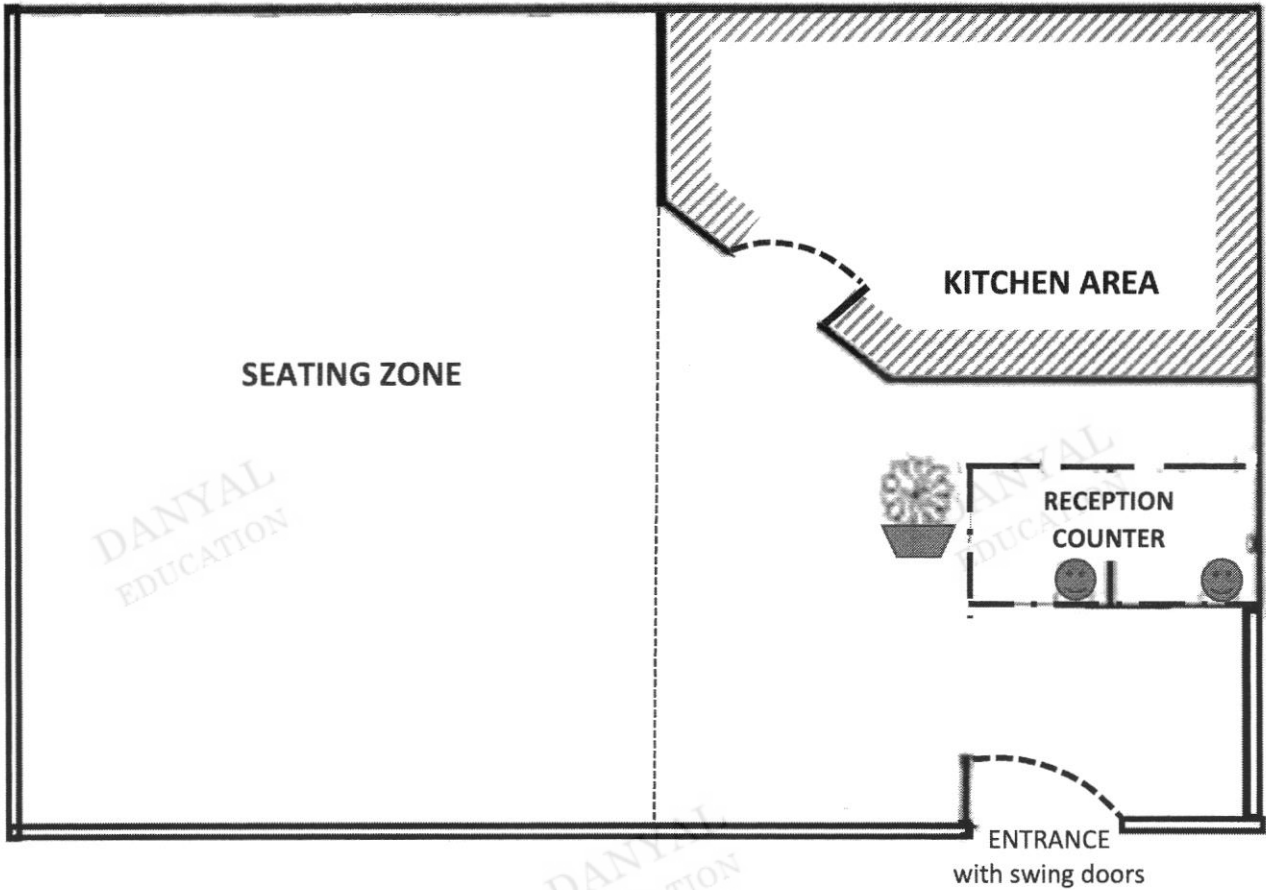

Legend

— Wall (you may assume negligible thickness in the calculations)



▬ Floor to ceiling glass panels (you may assume negligible thickness in the calculations)

Scale 1 cm : 2 m

The floor of the demarcated **seating zone** is covered in tiles.

Christy decides to renovate her café by changing all the floor tiles and repaint the walls in the seating zone and the ceiling of the whole café.

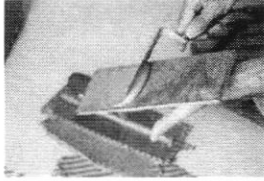
Information on floor tiles, paint and other charges for renovation is shown in the table on the next page.

Information on Floor Tiles (inclusive of 7% Goods and Services Tax)			
Cost of Floor Tiles (sold in stacks of 8)		Choice	
	Tiles dimensions (in mm)	500×500	300×600
	Cost per stack (\$)	48	40
Cost of Thinset Mortar 	Cost of 1 bag (\$)	32.50	
	Number of bags required 	40	

Information on Paint		
Type of Paint	Odour-less Anti Mould Ceiling White (For ceiling only)	Odour-less EasyWash (For walls only)
Capacity per tin (in litres)	5	5
Area coverage (in m ²) per litre	10	13
Number of coats of paint needed	2	2
Cost per tin (\$) (inclusive of 7% Goods and Services Tax)	33.20	43.50

Source: <https://www.nipponpaint.com.sg/store/product-category/interior-paints/>

Charges of Contractor for Renovation (inclusive of 7% Goods and Services Tax)				
Labour cost	Removal of existing floor tiles & paint	Installation of floor tiles	Painting of walls and ceiling	Disposal of rubbish
Cost (\$) (inclusive of 7% Goods and Service Tax)	1800	500	1600	120

On top of the renovation, Christy also intends to purchase new sets of tables and chairs to replace the old ones in the seating zone. **Each set (which contains one table and four chairs)** costs \$995 (inclusive of 7% Goods and Services Tax).

- (a) The seating zone can fit **18 sets** in the seating zone.
Calculate the total cost (inclusive of 7% Goods and Services Tax) of these 18 sets of tables and chairs which Christy intends to buy.

DANYAL
EDUCATION

DANYAL
EDUCATION

Answer \$ [1]

- (b) Find the floor area of the seating zone which is to be covered with new floor tiles.
Give your answer in square metres.

DANYAL
EDUCATION

DANYAL
EDUCATION

DANYAL
EDUCATION

Answer m² [2]

The ceiling height in the café is 3.5 metres high.

- (c) Calculate the total area, in square metres, of the walls in the seating zone and ceiling of the whole café, which will be repainted.

DANYAL
EDUCATION

DANYAL
EDUCATION

DANYAL
EDUCATION

Answerm² [3]

- (d) Christy decides to set aside a sum of **\$30 000** for the renovation and to purchase new sets of tables and chairs in the café.

Explain if the sum of money is sufficient. Justify your answers and show your calculations clearly.

Answer

DANYAL
EDUCATION

DANYAL
EDUCATION

Continuation of writing space for Question 10.

DANYAL
EDUCATION

DANYAL
EDUCATION

DANYAL
EDUCATION

DANYAL
EDUCATION

DANYAL
EDUCATION

[7]

END OF PAPER

PRESBYTERIAN HIGH SCHOOL



**MATHEMATICS
PAPER ONE**

4048/01

MARK SCHEME

DANYAL
EDUCATION

DANYAL
EDUCATION

DANYAL
EDUCATION

DANYAL
EDUCATION

DANYAL
EDUCATION

Answer all the questions.

- 1 Simplify $7y - 5x - 2(y + 3x)$.

$$\begin{aligned} & 7y - 5x - 2(y + 3x) \\ & = 5y - 11x \quad \text{--- B1: correct } 5y \\ & \quad \quad \quad \text{--- B1: correct } -11x \end{aligned}$$

- 2 Factorise $2x^2 - 50$.

$$\begin{aligned} & 2x^2 - 50 \\ & = 2(x^2 - 25) \quad \text{--- M1} \\ & = 2(x - 5)(x + 5) \quad \text{--- A1} \end{aligned}$$

- 3 (a) Write down the fraction(s) that is/are equivalent to $\frac{a}{b}$

$$\frac{b}{a} \quad \frac{1}{\frac{b}{1}} \quad \frac{a+1}{b+1} \quad \frac{a^2}{b^2}$$

$$\frac{1}{\frac{b}{1}} \quad \text{--- B1}$$

- (b) Given that $p = 3q$ and $2q = r$, write down the ratio of $p : q : r$.

$$3 : 1 : 2 \quad \text{--- B1}$$

- 4 The line graph below in an advertisement shows the brightness of teeth after using Charcoal Brand toothpaste.

Brightness of teeth after using Charcoal Brand toothpaste

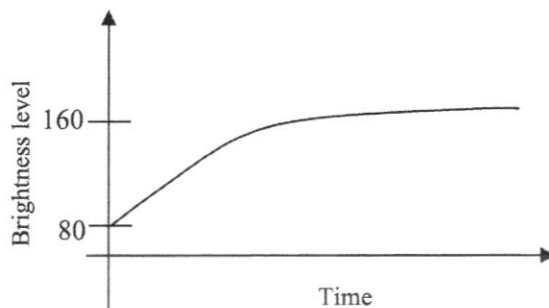

The advertisement claims that

'Your teeth will turn doubly bright after using Charcoal Brand toothpaste for a short time.'

Do you agree with the claim? Give **two** reasons to support your answer.

Disagree.

- (1) The time axis has no scale. We have no idea the amount of time required to improve the brightness level to increase from 80 to 160 units / double.
- (2) The vertical axis starts from 80 units. This may give readers a wrong impression that the brightness level of teeth for all users starts from 80 and that 160 units for the brightness level is the suggested ideal optimal level. Therefore, we cannot interpret how the brightness level of teeth is measured.
- (3) The scientific units for measurement of the brightness level is not stated. Hence, we do not know if the difference between 80 and 160 units truly shows the double brightness improvement.
- [B1: for each reason o.e. ; no mark if seen only disagree but unable to reason out]

- 5 Solve the equation $\frac{3x-5}{4} - \frac{x}{6} = 3$.

$$\frac{3x-5}{4} - \frac{x}{6} = 3$$

$$\frac{9x-15-2x}{12} = 3 \quad \text{--- M1: seen common denominator and attempt to simplify numerator}$$

$$7x = 51$$

$$x = \frac{51}{7} \quad \text{--- A1 or 7.29 (3s.f.)}$$

- 6 A number has exactly eight factors. Two of the factors are 18 and 27. List all the factors of the number.

1, 2, 3, 6, 9, 18, 27, 54 --- B1: for **every** 3 correct factors

- 7 Alicia has 504 one-centimetre cubes.
She arranges all the cubes into a cuboid.
If the largest area of the base of the cuboid is a perfect square, find the smallest possible height of the cuboid.

$$504 = 2^3 \times 3^2 \times 7 \quad \text{--- M1}$$

From the prime factors, the largest perfect square which may be derived for its base area

$$= (2 \times 3) \times (2 \times 3)$$

The smallest possible height = $2 \times 7 = 14$ cm ---- A1

- 8 (a) Calculate $\frac{11.9^3}{6.43 - 2.51}$.

Write down the first five digits of your answer.

429.88 --- B1

- (b) Write your answer to **part (a)** correct to 2 significant figures.

430 --- B1

- 9 The following stem and leaf diagram shows the height, in cm, of 10 Secondary Four students.

Stem	Leaf
14	8 9
15	4 9
16	0 2 3
17	0 1 1

Key: 14 | 6 means 146 cm

For the heights, find

- (a) the range,

23 cm --- B1

- (b) the median.

161 cm --- B1

- 10 Given that $81^n \div 9 = 3^{\frac{1}{2}}$, find the value(s) of n .

$$3^{4n} \div 3^2 = 3^{\frac{1}{2}}$$

$$3^{4n-2} = 3^{\frac{1}{2}} \text{ --- M1: seen either } 3^{4n} \text{ and/or apply law of indices}$$

$$4n-2 = \frac{1}{2} \text{ --- M1}$$

$$8n-4 = 1$$

$$n = \frac{5}{8} \text{ --- A1}$$

- 11 Mrs. Mok deposited \$ P in GAIN Bank for 3 years.
GAIN Bank pays a compound interest of 1.86% per annum to its depositors.
At the end of 3 years, Mrs. Mok withdrew a total of \$264 211.08. How much interests did Mrs. Mok earn? Give your answer to the nearest cent.

$$P \left(1 + \frac{1.86}{100} \right)^3 = \$264\,211.08 \text{ --- M1}$$

$$P = \$250\,000$$

$$\begin{aligned} \text{Interests} &= \$264\,211.08 - \$250\,000 \text{ --- M1} \\ &= \$14\,211.08 \text{ --- A1} \end{aligned}$$

- 12 (a) A range of values of x is represented on the number line below.

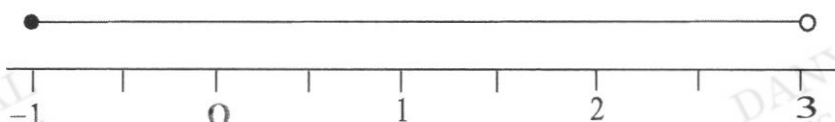

Write down inequalities that represent this range of values for x .

$$-1 \leq x < 3 \text{ --- B1}$$

- (b) Solve the inequality $\frac{x+3}{2} > 5-4x$.

$$\frac{x+3}{2} > 5-4x$$

$$x+3 > 10-8x \text{ --- M1}$$

$$9x > 7$$

$$x > \frac{7}{9} \text{ --- A1}$$

- 13 $\xi = \{\text{integers } x : 2 \leq x \leq 12\}$

The Venn diagram shows the elements of ξ and three sets A , B and C .

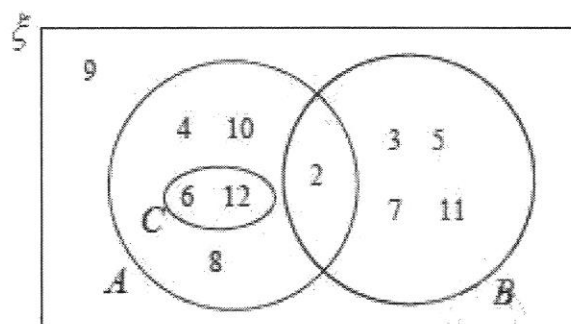

Use one of the notations below to complete each statement.

$$\subset \quad \supset \quad \in \quad \notin \quad \ni$$

(a) $9 \in (A \cup B)$ — B1

(b) $\{3, 5\} \subset A$ — B1

(c) $B \cap C = \emptyset$ — B1

- 14 y is inversely proportional to x . It is given that $y = 4$ when $x = 4$.

(a) Find an equation connecting x and y .

$$y = \frac{16}{x} \quad \text{--- B1}$$

(b) Find the percentage change in y when x is increased to 200%.

$$y_{\text{New}} = \frac{16}{2x} \quad \text{--- (or M1)}$$

$$\text{Percentage change} = \frac{\frac{16}{2x} - \frac{16}{x}}{\frac{16}{x}} \times 100\%$$

$$= -50\% \quad \text{--- A1 or M1 (if seen 50% only)}$$

- 15 In the diagram, ABC is a triangle in which $AB = AC$.
The side AC is produced to P such that $CP = AC$ and CB is produced to Q such that $QB = BC$.

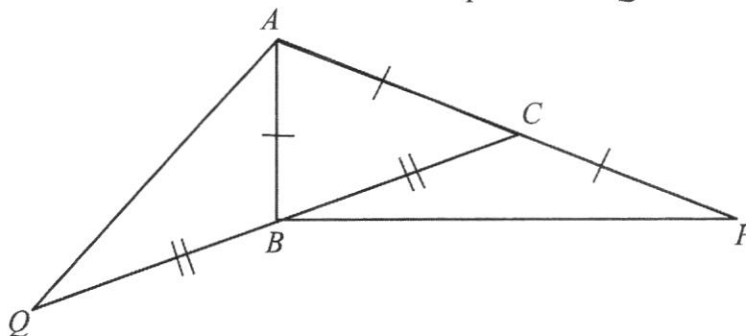

Show that triangles AQB and PBC are congruent.

Answer

1. $BQ = BC$ (given)
2. $AB = PC$ (given) --- M1: seen both (1) & (2)
3. $\angle ABQ = 180 - \angle ABC$ (adj. \angle on a str. line)
 $= 180 - \angle ACB$
 $= \angle PCB$ (adj. \angle on a str. line)
 --- M1: seen logical deduction of equivalent angles
 $\therefore \triangle AQB \equiv \triangle PBC$ (SAS) --- A1

- 16 (a) Convert 720 m/h into m/s.

$$0.2 \text{ m/s} \text{ --- B1}$$

- (b) A map has a scale of 1 : 500 000.

The bullet train, "Shinkansen", operates on Japan's high-speed railway network at a speed of 320 km/h. It takes 1 hour and 30 minutes to travel from Tokyo to Fukushima.

Find the distance of the Shinkansen track, in cm, on the map between Tokyo and Fukushima.

$$1 \text{ cm rep } 500\,000 \text{ cm}$$

$$1 \text{ cm rep } 5 \text{ km} \text{ --- M1}$$

$$\text{Actual distance} = 320 \times 1.5 = 480 \text{ km} \text{ --- M1}$$

$$\text{Distance on the map} = \frac{480}{5} = 96 \text{ cm} \text{ --- A1}$$

- 17 (a) Express $x^2 - 4x + 5$ in the form $(x - p)^2 + q$.

$$x^2 - 4x + 5$$

$$= x^2 - 4x + (-2)^2 - (-2)^2 + 5 \quad \text{--- M1: seen } +(-2)^2 - (-2)^2 \text{ in the factorisation}$$

$$= (x - 2)^2 + 1 \quad \text{--- A1}$$

- (b) Sketch the graph of $y = x^2 - 4x + 5$ on the axes below.

Indicate clearly on the graph, its turning point and intersection with the y-axis.

Answer

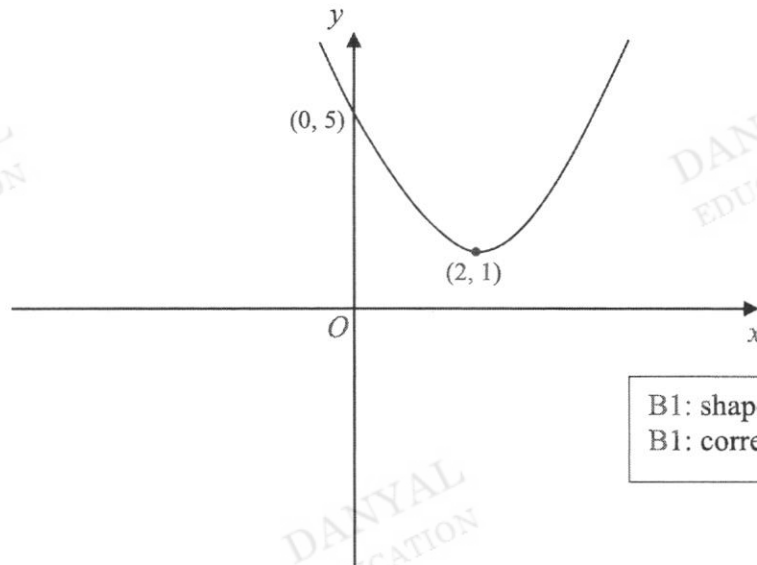

B1: shape and turning point
B1: correct y-intercept

- 18 The position vector of point J is $\begin{pmatrix} 2 \\ 3 \end{pmatrix}$.

The point K is the result of translation of the point J by $\begin{pmatrix} 6 \\ -4 \end{pmatrix}$.

- (a) Write down the coordinates of point K .

$$(8, -1) \quad \text{--- B1}$$

- (b) Find the magnitude of \overrightarrow{JK} .

$$\text{Magnitude} = \sqrt{6^2 + (-4)^2} \quad \text{--- M1}$$

$$= \sqrt{52} = 7.21 \quad \text{--- A1}$$

- (c) Given that $\overrightarrow{KN} = \overrightarrow{JK}$, find the coordinates of point N .

$$(14, -5) \quad \text{--- B1}$$

- 19 (a) Simplify $(x^6)^{-\frac{2}{3}}$ and leave your answer in positive index notation.

$$\frac{1}{x^4} \text{ --- B1}$$

- (b) Solve these simultaneous equations.

$$6x - 2y = 19$$

$$8x + 5y = 10$$

$$6x - 2y = 19 \text{ --- (1)}$$

$$8x + 5y = 10 \text{ --- (2)}$$

$$(1) \times 5: 30x - 10y = 95$$

$$(2) \times 2: 16x + 10y = 20 \text{ --- M1: manipulate to obtain } 10y$$

$$\text{Add: } 46x = 115$$

$$x = \frac{5}{2} \text{ and } y = -2 \text{ --- A1, A1}$$

$$6x - 2y = 19 \text{ --- (1)}$$

$$8x + 5y = 10 \text{ --- (2)}$$

$$(1) \times 4: 24x - 8y = 76$$

$$(2) \times 3: 24x + 15y = 30 \text{ --- M1: manipulate to obtain } 24x$$

$$\text{Subtract: } 23y = -46$$

$$y = -2 \text{ and } x = \frac{5}{2} \text{ --- A1, A1}$$

- 20 A construction site is in the shape of a quadrilateral $PQRS$, such that $QR = 11$ cm, $\angle PQR = 85^\circ$ and $PS = RS = 9.8$ cm. PQ has been drawn for you.

(a) Construct the quadrilateral $PRQS$.

[2]

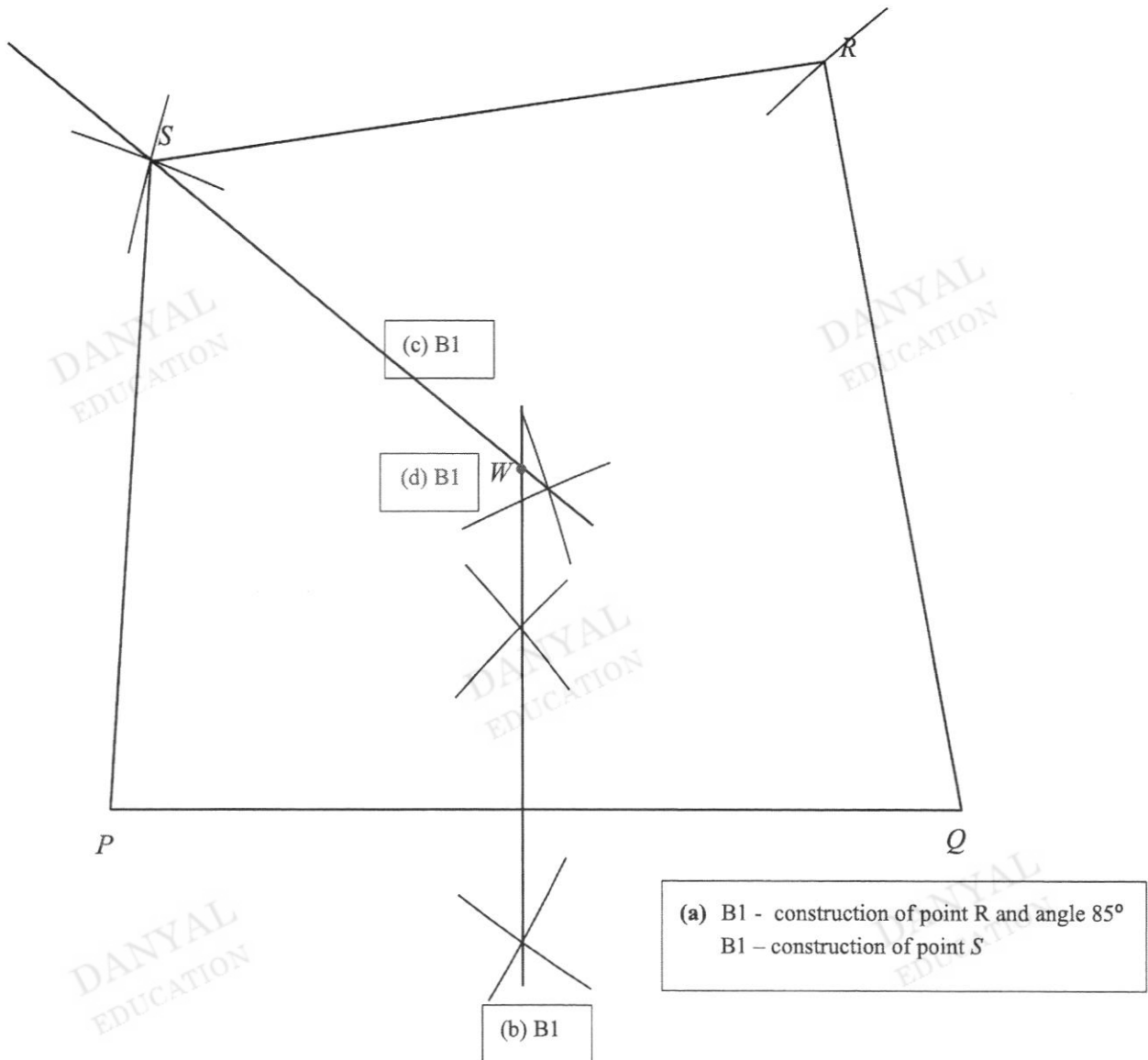

(b) Construct the perpendicular bisector of PQ . [1]

(c) Construct the bisector of angle PSR . [1]

(d) The letter ' W ' is at the intersection of the point where it is equidistant from P and Q , and equidistant from the sides of PS and RS . Mark and label the letter ' W ' to indicate its position. [1]

21 The ages of 10 children are given below.

9, 7, 8, 9, 6, x , 4, 10, 7, $x+2$

(a) If the mean age is 8 years, show that $x=9$.

Answer

$$\frac{9+7+8+9+6+x+4+10+7+x+2}{10} = 8 \quad \text{--- B1}$$

Solve x : $x=9$ (shown)

(b) Calculate the standard deviation.

$$\sqrt{\frac{4^2 + 6^2 + 2(7)^2 + 8^2 + 3(9)^2 + 10^2 + 11^2}{10}} - 8^2 \quad \text{--- M1: apply method to find SD}$$

= 1.95 (3 s.f.) --- A1

(c) Another 3 children, each of them 8 years in age, were added to the above data set. Without any re-calculations, describe clearly how, the mean and the standard deviation will be affected, if any.

Answer

New mean will still be 8 years. --- B1

New SD will be smaller than (b). --- B1

- 22 The diagram below shows three points $P(-4, 2)$, $Q(2, 10)$ and $R(-4, -5)$.

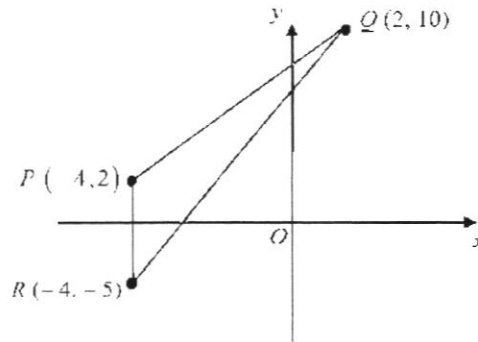

- (a) Find the length of PQ .

$$10 \text{ units} \quad \text{--- B1}$$

- (b) Find the exact value of $\cos \angle QPR$.

$$-\frac{4}{5} \quad \text{--- B1}$$

- (c) Find the area of triangle PQR .

$$\text{Area of triangle} = \frac{1}{2} \times 7 \times 6 = 21 \text{ sq. units} \quad \text{--- B1}$$

- (d) The line $mx + 10y + 5 = 0$ has the same gradient as QR .
Find the value of m .

$$\text{Gradient of } QR = \frac{10 - (-5)}{2 - (-4)} = \frac{5}{2} \quad \text{--- M1}$$

$$mx + 10y + 5 = 0$$

$$10y = -mx - 5$$

$$y = -\frac{m}{10}x - \frac{1}{2}$$

$$\text{Equate: } -\frac{m}{10} = \frac{5}{2} \quad \text{--- M1}$$

$$m = -25 \quad \text{--- A1}$$

- 23 The diagram shows the speed-time graph of two objects, A and B , for the first 12 seconds of their journey. Both objects started at the same point and moved in the same direction.

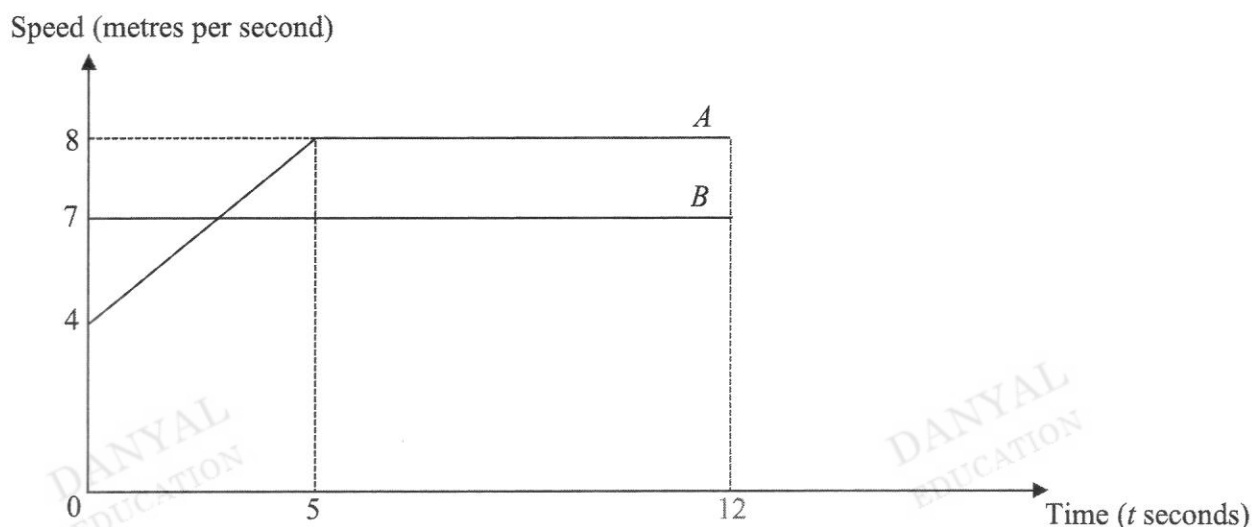

- (a) Find the speed of object A at $t = 2.5$.

$$6 \text{ m/s} \quad \text{--- B1}$$

- (b) Determine whether object A has overtaken object B at $t = 5$.
Explain your answer.

$$\text{Distance travelled by object } A = \frac{1}{2} \times (4 + 8) \times 5 = 30 \text{ m}$$

$$\text{Distance travelled by object } B = 7 \times 5 = 35 \text{ m}$$

(M1: attempt to calculate the respective distances travelled by A and B)

Object A has not overtaken object B at $t = 5$. --- A1

- (c) Both objects slowed down at the same rate after 12 seconds.
Object B came to rest after a further 3.5 seconds.
Calculate the time taken for object A to come to rest.

Object B decelerates at 2 m/s^2 [Acceleration = -2 m/s^2] --- M1

Let t be the time taken for object A to stop.

$$\frac{8-0}{12-t} = -2 \quad \text{--- M1}$$

$$t = 16 \quad \text{--- A1}$$

- 24 A picture frame measures 28 cm by 20 cm. A painted picture of area 300 cm^2 is placed on the frame with a border of uniform width of x cm on all four sides.

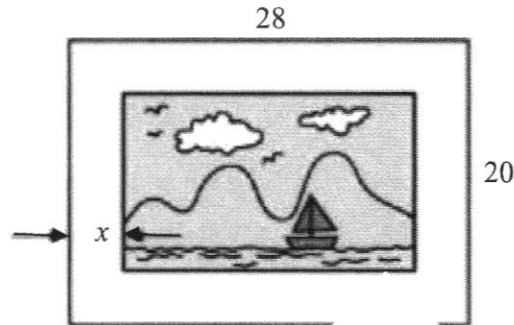

- (a) Form an equation in x and show that $x^2 - 24x + 65 = 0$.

Length of picture = $(28 - 2x)$ cm and Breadth of picture = $(20 - 2x)$ cm --- M1

$$(28 - 2x)(20 - 2x) = 300 \text{ --- M1}$$

$$560 - 56x - 40x + 4x^2 = 300$$

$$4x^2 - 96x + 260 = 0$$

$$x^2 - 24x + 65 = 0 \text{ (shown) --- AG1}$$

- (b) Hence, find the width of the border. Give your answer to 2 decimal places.

$$x^2 - 24x + 65 = 0$$

$$x = \frac{-(-24) \pm \sqrt{(-24)^2 - 4(1)(65)}}{2} = \frac{24 \pm \sqrt{316}}{2} \text{ --- M1: correct use of Quadratic Formula}$$

$$x = 20.888 \text{ or } 3.111 \text{ --- M1: for both answers seen to the QE}$$

Hence the width of the border 3.11 cm --- A1

END OF PAPER

PRESBYTERIAN HIGH SCHOOL



**MATHEMATICS
PAPER TWO**

4048/02

MARK SCHEME

DANYAL
EDUCATION

DANYAL
EDUCATION

DANYAL
EDUCATION

DANYAL
EDUCATION

DANYAL
EDUCATION

1 (a) It is given that $V = \frac{2\pi}{3}(a-b)$.

(i) Evaluate V when $a = 2.8$ and $b = 1.7$.

$$\begin{aligned} V &= \frac{2\pi}{3}(a-b) \\ &= \frac{2\pi}{3}(2.8-1.7) = 2.30 \quad \text{--- B1} \end{aligned}$$

(ii) Express b in terms of V , π and a .

$$\begin{aligned} V &= \frac{2\pi}{3}(a-b) \\ \frac{3V}{2\pi} &= a-b \quad \text{--- M1: attempt to manipulate} \\ b &= a - \frac{3V}{2\pi} \quad \text{--- A1} \end{aligned}$$

(b) Simplify $\frac{x}{10y} \div \frac{4xy^2}{5}$.

$$\begin{aligned} \frac{x}{10y} \div \frac{4xy^2}{5} \\ &= \frac{x}{10y} \times \frac{5}{4xy^2} \quad \text{--- M1: some form of simplification} \\ &= \frac{1}{8y^3} \quad \text{--- A1} \end{aligned}$$

(c) (i) Expand $(2p-q)^2$.

$$4p^2 - 4pq + q^2 \quad \text{--- B1}$$

(ii) Given that $2p-q=7$ and $4p^2+q^2=63$, without solving for p and q , find the value of pq .

$$\begin{aligned} (2p-q)^2 &= 4p^2 - 4pq + q^2 \\ \text{Since } (2p-q)^2 &= 7^2 = 49, \\ 4p^2 - 4pq + q^2 &= 49 \\ \text{Also } 4p^2 + q^2 &= 63, \\ \Rightarrow 63 - 49 = 14 &= 4pq \quad \text{--- M1: attempt to simplify to this step} \\ \therefore pq &= 3.5 \quad \text{--- A1} \end{aligned}$$

- 2 (a) The cumulative frequency curve illustrates the marks scored, out of 100, by 200 students for a Mathematics Test.

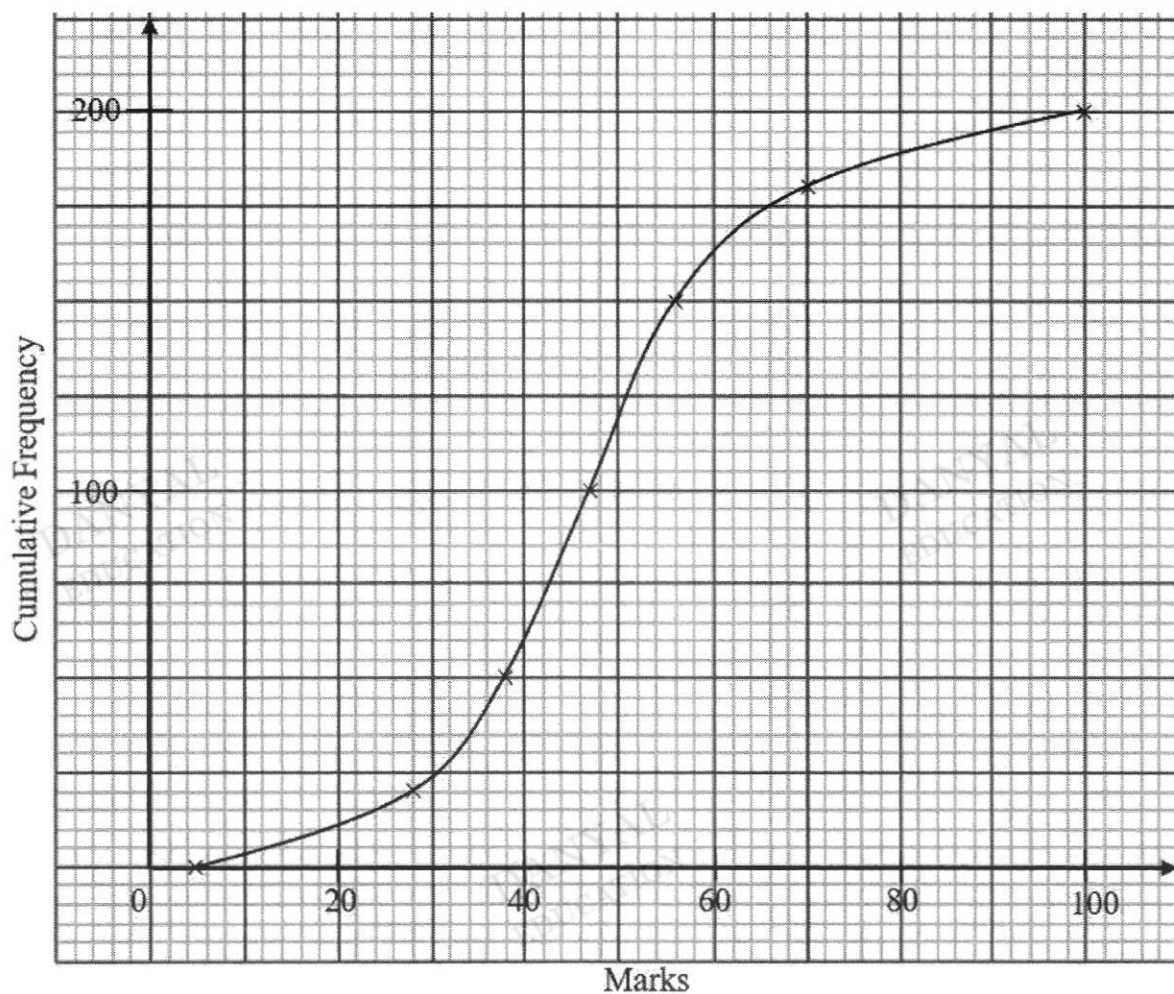

Use the curve to estimate

- (i) the median marks scored,

$$47 \text{ marks} \quad \text{--- B1}$$

- (ii) the interquartile range of the marks scored,

$$\begin{aligned} \text{IQR} &= 56 - 38 \quad \text{--- M1} \\ &= 18 \quad \text{--- A1} \end{aligned}$$

- (iii) the number of students who scored at least 66 marks.

$$200 - 175 = 25 \text{ students} \quad \text{--- B1}$$

- (b) 20 plants were selected at random and the number of flowers bloomed on each plant were recorded in the table below.

Number of flowers	1	2	3	4
Number of plants	1	10	6	3

- (i) One of the plants is selected at random.
Find the probability that it has 3 flowers.

$$\frac{3}{10} \quad \text{--- B1}$$

- (ii) Two of the plants are selected at random, one after another.
Find, as a fraction in its simplest form, the probability that

- (a) one of the plants had 1 flower, and the other plant had 2 flowers,

$$\left(\frac{1}{20} \times \frac{10}{19}\right) + \left(\frac{10}{20} \times \frac{1}{19}\right)$$

--- M1: award for seen at least one pair of probabilities

$$= \frac{1}{19} \quad \text{--- A1}$$

- (b) both plants had the same number of flowers.

$$\left(\frac{10}{20} \times \frac{9}{19}\right) + \left(\frac{6}{20} \times \frac{5}{19}\right) + \left(\frac{3}{20} \times \frac{2}{19}\right)$$

--- M1: at least 2 pairs of correct probabilities

$$= \frac{63}{190} \quad \text{--- A1}$$

- 3 (a) The energy consumption of households in Singapore for the year 2019, in kilo tonnes of oil equivalent (ktoe), is 747.2.

Source: <https://www.statista.com/statistics/973038/singapore-household-related-energy-consumption/>

The International Energy Agency defines one tonne of oil equivalent (toe) to be:

1 tonne of oil equivalent (toe) = 11 630 kilowatt hours (kWh)

- (i) Calculate the total amount of energy consumed by households in kWh.
Give your answer in standard form correct to 3 significant figures.

$$\text{Amount of energy} = 747.2 \times 10^3 \text{ toe}$$

$$1 \text{ tonne of oil equivalent (toe)} = 11\,630 \text{ kilowatt hours (kWh)}$$

$$747.2 \times 10^3 \text{ toe} = 747.2 \times 10^3 \times 11\,630 \text{ kWh} \text{ --- M1}$$

$$= 8\,689\,936\,000 \text{ kWh}$$

$$= 8.69 \times 10^9 \text{ kWh (3s.f.) --- A1}$$

- (ii) From 2015 to 2019, the energy consumption of households has increased by 6%.
Calculate the energy consumption of households in 2015.
Give your answer to the nearest ktoe.

$$106\% \text{ rep } 747.2 \text{ ktoe (2019) --- M1: able to connect with the percentage}$$

$$100\% \text{ rep } 704.905 \text{ ktoe} \approx 705 \text{ ktoe (2015) --- A1}$$

- (b) Andrea and Bella are two sale promoters who work at a Beauty Pop-up Store.
The table below shows the number of beauty products each of them sold in the month of July.

	Eye Cream	Face Serum	Lip Balm
Andrea	21	28	10
Bella	27	20	8

- (i) Represent the above information in a 2×3 matrix, \mathbf{M} .

$$\mathbf{M} = \begin{pmatrix} 21 & 28 & 10 \\ 27 & 20 & 8 \end{pmatrix} \text{ --- B1}$$

- (ii) The commission for each eye cream, face serum and lip balm sold is \$1.20, \$1.50 and \$1.00 respectively. Represent the commission in a 3×1 column matrix \mathbf{F} .

$$\mathbf{F} = \begin{pmatrix} 1.2 \\ 1.5 \\ 1 \end{pmatrix} \text{ --- B1}$$

(iii) Evaluate the matrix $\mathbf{N} = \mathbf{MF}$.

$$\begin{aligned} \mathbf{N} &= \begin{pmatrix} 21 & 28 & 10 \\ 27 & 20 & 8 \end{pmatrix} \begin{pmatrix} 1.2 \\ 1.5 \\ 1 \end{pmatrix} \\ &= \begin{pmatrix} 21 \times 1.2 + 28 \times 1.5 + 10 \times 1 \\ 27 \times 1.2 + 20 \times 1.5 + 8 \times 1 \end{pmatrix} \\ &\quad \text{--- M1: with 1 correct value} \\ &= \begin{pmatrix} 77.2 \\ 70.4 \end{pmatrix} \quad \text{--- A1: accurate answers presented in a matrix form} \end{aligned}$$

(iv) State what each element of \mathbf{N} represent.

\$77.20 represents the **amount of money Andrea received as commission from the sales** of the beauty products sold.

\$70.40 represents the **amount of money Bella received as commission from the sales** of the beauty products sold.

B1: for correctly explanation using the words in bold

(v) If the commission for each eye cream sold remains the same while the commission for each face serum sold is reduced by 6% and the commission for each lip balm is increased by 10%, write down a matrix \mathbf{Q} such that \mathbf{QF} represents the new amount of commission for each of the three beauty products.

$$\mathbf{Q} = \begin{pmatrix} 1 & 0 & 0 \\ 0 & 0.94 & 0 \\ 0 & 0 & 1.10 \end{pmatrix}$$

- 4 In the diagram below, O is the centre of the circle passing through A , B , C and D . AD is the diameter of the circle, and AT and BT are tangents to the circle. Angle $ACB = 24^\circ$ and angle $OBC = 66^\circ$.

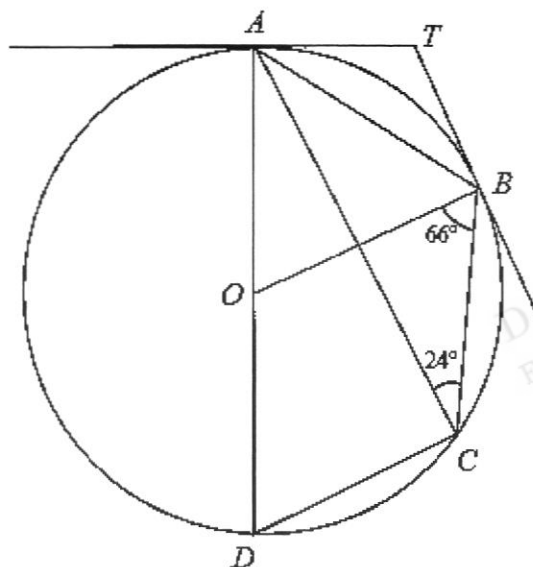

- (a) Find angle AOB .
Give a reason for each step of your working.

$$\begin{aligned}\angle AOB &= 24 \times 2 \quad (\angle \text{ at centre} = \text{twice } \angle \text{ at circumference}) \text{ --- M1: seen reason} \\ &= 48 \quad \text{--- A1}\end{aligned}$$

- (b) Find angle DAB .
Give a reason for each step of your working.

$$\begin{aligned}\angle DAB &= \frac{180 - 48}{2} \quad (\text{base } \angle \text{ s of isos. triangle}) \text{ --- M1} \\ &= 66 \quad \text{--- A1}\end{aligned}$$

- (c) Find angle ATB .
Give a reason for each step of your working.

$$\begin{aligned}\angle OAT &= 90 \quad (\text{tangent } \perp \text{ radius}) \text{ --- M1: seen reason for 90} \\ \angle ATB &= 360 - 2(90) - 48 \quad (\angle \text{ sum of quadrilateral}) \\ &= 132 \quad \text{--- A1}\end{aligned}$$

- (d) Find angle ADC .
Give a reason for each step of your working.

$$\begin{aligned}\angle ADC &= 180^\circ - 2(66^\circ) \quad (\angle\text{s. in opp. segment}) \quad \text{--- M1} \\ &= 48^\circ \quad \text{--- A1}\end{aligned}$$

- (e) Show that $OBCD$ is a trapezium.

$$\begin{aligned}\angle DOB &= 180 - 48 \quad (\text{adj. } \angle \text{ on a str. line}) \\ &= 132\end{aligned}$$

M1: deduced angle

$$\begin{aligned}\text{Since } \angle BOD + \angle ODC &= 132 + 48 \\ &= 180\end{aligned}$$

by property of interior angles, $OB \parallel DC$.

Therefore, $OBCD$ is a trapezium.

A1: seen conclusion for trapezium; mentioned property of interior angles, // sides.

OR

$$\angle DCA = 90 \quad (\angle \text{ in a semicircle})$$

M1: deduced angle

$$\begin{aligned}\text{Since } \angle DCB + \angle OBC &= 90 + 24 + 66 \\ &= 180\end{aligned}$$

by property of interior angles, $OB \parallel DC$.

Therefore, $OBCD$ is a trapezium.

A1: seen conclusion for trapezium; mentioned property of interior angles, // sides.

OR

Since $\angle ADC = \angle AOB = 48$ (found in earlier parts),
we can conclude that they form a pair of corresponding angles, $OB \parallel BC$.

M1: deduced angle

Given one pair of parallel sides, we can conclude that $OBCD$ is a trapezium.

A1: seen conclusion for trapezium; mentioned property of // sides as the proving factor.

- 5 (a) (i) The first four terms of a sequence are 1, 4, 7 and 10.
Express the n th term of this sequence in terms of n .

$$1 + (n-1)(3) = 3n - 2 \quad \text{--- B1}$$

Consider another sequence of numbers given below.

$$v_1 = 2^2 - 1$$

$$v_2 = 2^3 - 4$$

$$v_3 = 2^4 - 7$$

$$v_4 = 2^5 - 10$$

.

.

.

- (ii) Write down an expression for v_5 .

$$v_5 = 2^6 - 13 \quad \text{--- B1}$$

- (iii) Write down, without simplifying, an expression in terms of n , for v_n of this sequence.

$$v_n = 2^{n+1} - (3n - 2) \quad \text{--- B1}$$

- (iv) Show that $v_{11} = 4065$.

Either by listing method or seen substitution for $n = 11$ into the expression in (iii).
- B1 / AG1

- (v) Hence or otherwise, find the smallest value of n such that $v_n > 65000$.

$$n = 15 \quad \text{--- B1}$$

- (b) (i) Four of the interior angles of a hexagon are each 105° . One of the remaining interior angles is three times larger than the other interior angle. Find the size of the smaller interior angle.

$$4(105^\circ) + 3x + x = (6 - 2) \times 180^\circ$$

--- M1: formulate expression for sum of interior angles

--- M1: apply formula for total sum of interior angles in a hexagon

Solving x :

$$420 + 4x = 720$$

$$x = 75 \quad \text{--- A1}$$

- (ii) Given that an n -sided regular polygon has an exterior angle of 24° , find the number of sides of this polygon.

$$\text{Sum of exterior angles} = 360$$

$$\text{Each exterior angle} = \frac{360}{n} = 24 \quad \text{--- M1}$$

$$n = 15$$

There are 15 sides to this polygon. --- A1

- 6 X, Y and Z are points on horizontal ground such that Z is due east of X . It is also given that $XY = 36$ m, $XZ = 82$ m and angle $YXZ = 75^\circ$.

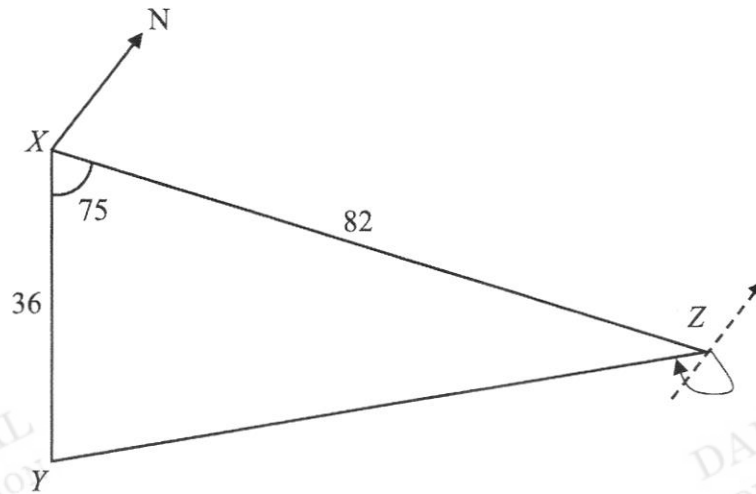

Calculate
(a) YZ ,

$$YZ^2 = 36^2 + 82^2 - 2(36)(82)\cos 75 \quad \text{--- M1}$$

$$YZ = \sqrt{36^2 + 82^2 - 2(36)(82)\cos 75} \quad \text{--- M1}$$

$$YZ = 80.5725 \text{ m} \approx 80.6 \text{ m (3s.f.)} \quad \text{--- A1}$$

(b) the bearing of Y from Z ,

$$\frac{\sin \angle XZY}{36} = \frac{\sin 75}{80.5725} \quad \text{--- M1}$$

$$\sin \angle XZY = 0.43157$$

$$\angle XZY = 25.567$$

$$\begin{aligned} \text{The required angle} &= 270 - 25.567 \quad \text{--- M1} \\ &= 244.4 \end{aligned}$$

$$\text{Bearing is } = 244.4 \text{ (1 d.p.)} \quad \text{--- A1}$$

(c) the shortest distance from X to YZ .

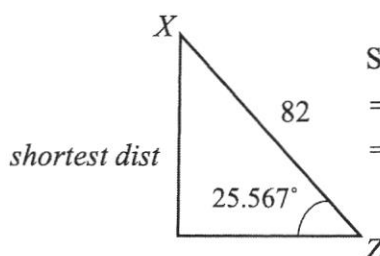

Shortest distance

$$= 82 \sin 25.567^\circ \quad \text{--- M1}$$

$$= 35.388 \text{ m} \approx 35.4 \text{ m (3s.f.)} \quad \text{--- A1}$$

Area of triangle XYZ

$$= \frac{1}{2} \times 36 \times 82 \times \sin 75$$

$$= 1425.7065 \text{ m}^2$$

$$\frac{1}{2} \times 80.5725 \times h = 1425.7065 \quad \text{--- M1}$$

$$h = 35.389 \text{ m} \approx 35.4 \text{ m} \quad \text{--- A1}$$

T is the top of a vertical pole erected at X .

The greatest angle of elevation of T when viewed along YZ is 10° .

(d) Find the height of the pole TX .

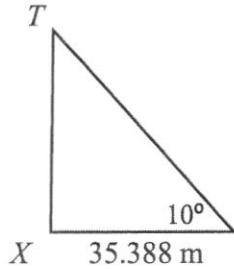

$$\tan 10^\circ = \frac{TX}{35.388}$$

$$TX = 35.388 \times \tan 10 \quad \text{--- M1}$$

$$TX = 6.24 \text{ m (3s.f.)} \quad \text{--- A1}$$

$\frac{\sin 80^\circ}{35.388} = \frac{\sin 10^\circ}{TX}$ $TX = 6.24 \text{ m}$

7 In the diagram below, $QR = 3QT$ and $XP = 3TX$. S is the midpoint of PR . $\overrightarrow{QT} = \mathbf{m}$ and $\overrightarrow{RS} = \mathbf{n}$.

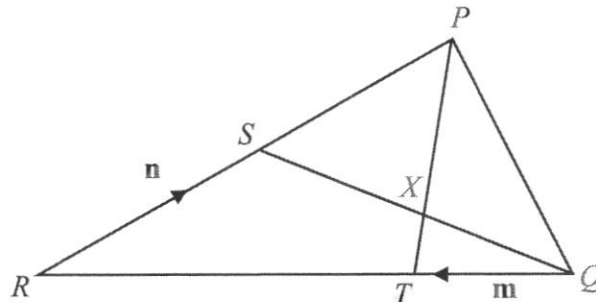

(a) Express in terms of \mathbf{m} and \mathbf{n} , as simply as possible,

(i) \overrightarrow{QS} ,

$$\overrightarrow{QS} = \overrightarrow{QR} + \overrightarrow{RS}$$

$$= 3\mathbf{m} + \mathbf{n} \quad \text{--- M1: seen correct } \overrightarrow{QR}$$

--- A1

(ii) \overrightarrow{TP} ,

$$\overrightarrow{TP} = \overrightarrow{TR} + \overrightarrow{RP}$$

$$= 2\mathbf{m} + 2\mathbf{n} \quad \text{--- M1: seen correct } \overrightarrow{RP}$$

--- A1

(b) Show that $\overrightarrow{QX} = \frac{3}{2}\mathbf{m} + \frac{1}{2}\mathbf{n}$.

$$\overrightarrow{QX} = \overrightarrow{QT} + \overrightarrow{TX}$$

$$= \mathbf{m} + \frac{1}{4}\overrightarrow{TP} \quad \text{--- M1: seen } \overrightarrow{TX} = \frac{1}{4}\overrightarrow{TP}$$

$$= \mathbf{m} + \frac{1}{4}(\overrightarrow{TR} + \overrightarrow{RP})$$

$$= \mathbf{m} + \frac{1}{4}(2\mathbf{m} + 2\mathbf{n}) \quad \text{--- M1: subst. vector}$$

$$= \frac{3}{2}\mathbf{m} + \frac{1}{2}\mathbf{n} \quad \text{--- AG1}$$

(c) Calculate the value of

(i) $\frac{QX}{QS}$,

$$\frac{1}{2} \quad \text{--- B1}$$

(ii) $\frac{\text{area of triangle } PQX}{\text{area of triangle } PQT}$,

$$\frac{\text{area of triangle } PQX}{\text{area of triangle } PQT} = \frac{3}{4} \quad \text{--- B1}$$

(iii) $\frac{\text{area of triangle } PSX}{\text{area of triangle } QXT}$,

$$\begin{aligned} \frac{\text{area of triangle } PSX}{\text{area of triangle } QXT} &= \frac{\text{area of triangle } PSX}{\text{area of triangle } PXQ} \times \frac{\text{area of triangle } PXQ}{\text{area of triangle } QXT} \\ &= 1 \times 3 \\ &= 3 \quad \text{--- B1} \end{aligned}$$

- 8 The diagram below shows the major segment XZY , of circle centre O , which is the cross-section of a 250 m long tunnel and track.

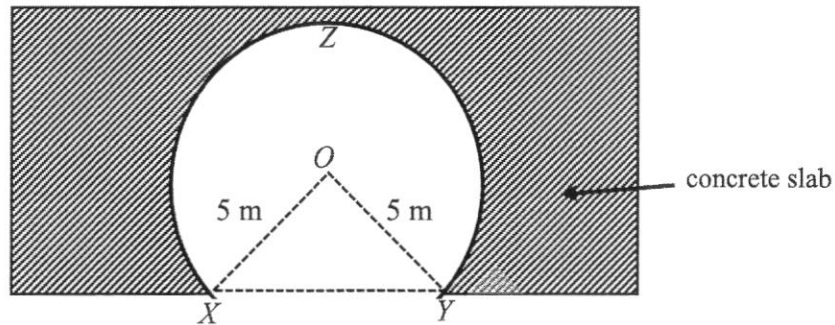

It is given that $OX = OY = 5$ m and the perimeter of $OXZYO$ is 32 m.

- (a) Show that the reflex angle XOY is 4.4 radians.

$$\text{Perimeter} = 32 = 5 + 5 + 5\theta \quad \text{--- M1}$$

$$\theta = \frac{32 - 10}{5} = 4.4 \text{ rad (shown)} \quad \text{--- AG1}$$

- (b) Find the total internal surface area of the tunnel and its track.

Total internal surface area

$$= [5(4.4) \times 250] + [XY \times 250]$$

$$XY^2 = 5^2 + 5^2 - 2(5)(5) \cos(2\pi - 4.4) \quad \text{--- M1}$$

$$XY = 8.08496 \text{ m}$$

Total internal surface area

$$= [5(4.4) \times 250] + [8.08496 \times 250]$$

--- M1: formulate curved SA XZY ; --- M1: area for rectangular base

$$= 7521.241 \text{ m}^2$$

$$= 7520 \text{ m}^2 \text{ (3s.f.)} \quad \text{--- A1}$$

- (c) The major segment of circle XYZ , can also be represented as the uniform cross-section of a circular container, **not filled** with sand sediment, as shown below.

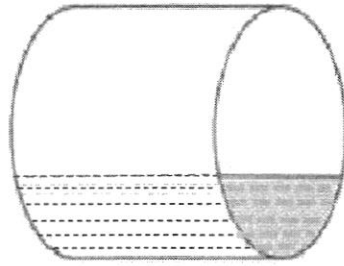

The container is 8 m long.

Calculate the volume of the container which is **not filled** with sand sediment.

Cross-sectional area

$$= \left(\frac{1}{2} \times 5 \times 5 \times \sin(2\pi - 4.4) \right) + \left(\frac{1}{2} \times 5 \times 5 \times 4.4 \right)$$

--- M1: area of triangle XOY ; --- M1: area of major sector

$$= 66.8950 \text{ m}^2$$

Volume of the container which is **not filled** with sand sediment

$$= 66.8950 \times 8 \quad \text{--- M1}$$

$$= 535.16 \text{ m}^3 \approx 535 \text{ m}^3 \text{ (3s.f.)} \quad \text{--- A1}$$

Alternatively:

Volume of cylinder – Volume filled with sand

$$= \left[\pi(5)^2(8) \right] - \left[\frac{1}{2} \times 5^2 \times (2\pi - 4.4) - \frac{1}{2} \times 5^2 \times \sin(2\pi - 4.4) \right] (8)$$

$$= 200\pi - [23.5398 - 11.89502](8)$$

$$= 535 \text{ m}^3$$

M1: Seen area of sector – area of triangle --- (a)

M1: Volume filled with sand = (a) x 8 --- (b)

M1: Volume of cylinder – (b)

A1: answer

- 9 Arnold bought a newborn Labrador Retriever. He recorded the mass of the puppy every Sunday morning. The table below shows some of the values captured, except when $t = 2$.

Age of puppy (t weeks)	0	1	2	3	4	5	6	7
Mass (m kg)	0.3	0.5		1.4	2.0	3.9	6.4	10.7

- (a) On the grid, plot the points given in the table for $0 \leq t \leq 7$ and join them with a smooth curve.

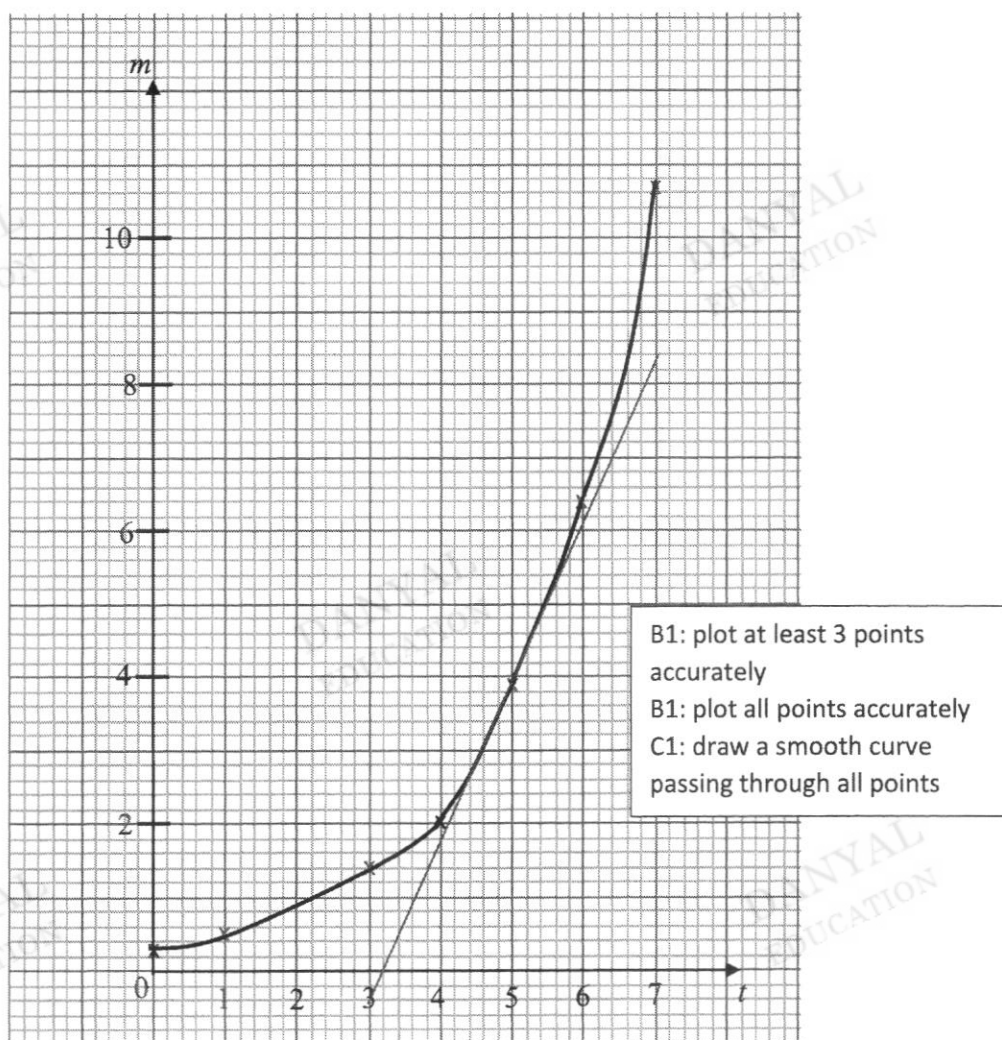

- (b) Arnold had forgotten to measure the puppy's mass in the second week. Use your graph to estimate the mass of the puppy in the second week.

0.8 kg --- B1 [accept 0.7 to 0.9 kg]

- (c) Use your graph to estimate the age of the puppy when its mass is 4.5 kg.

5.3 weeks --- B1 [accept 5.1 to 5.5 weeks]

- (d) (i) By drawing a suitable tangent, find the gradient of the curve at $t = 5$.

Appropriately draw a tangent at $t = 5$ ---- M1

Gradient = 2.67 (accept 2.3 to 2.93) --- A1

- (ii) What does this gradient represent?

The gradient represents the **rate of growth of the puppy when it was 5 weeks old.** – B1

- (e) The mass of the Labrador Retriever may be estimated by the function $m = ab^t$, where a and b are constants. Suggest appropriate values of a and of b .



$$a = 0.3 \text{ --- B1}$$

$$b = \frac{5}{3} = 1\frac{2}{3} \text{ --- B1 [accept 1.6 to 1.7]}$$

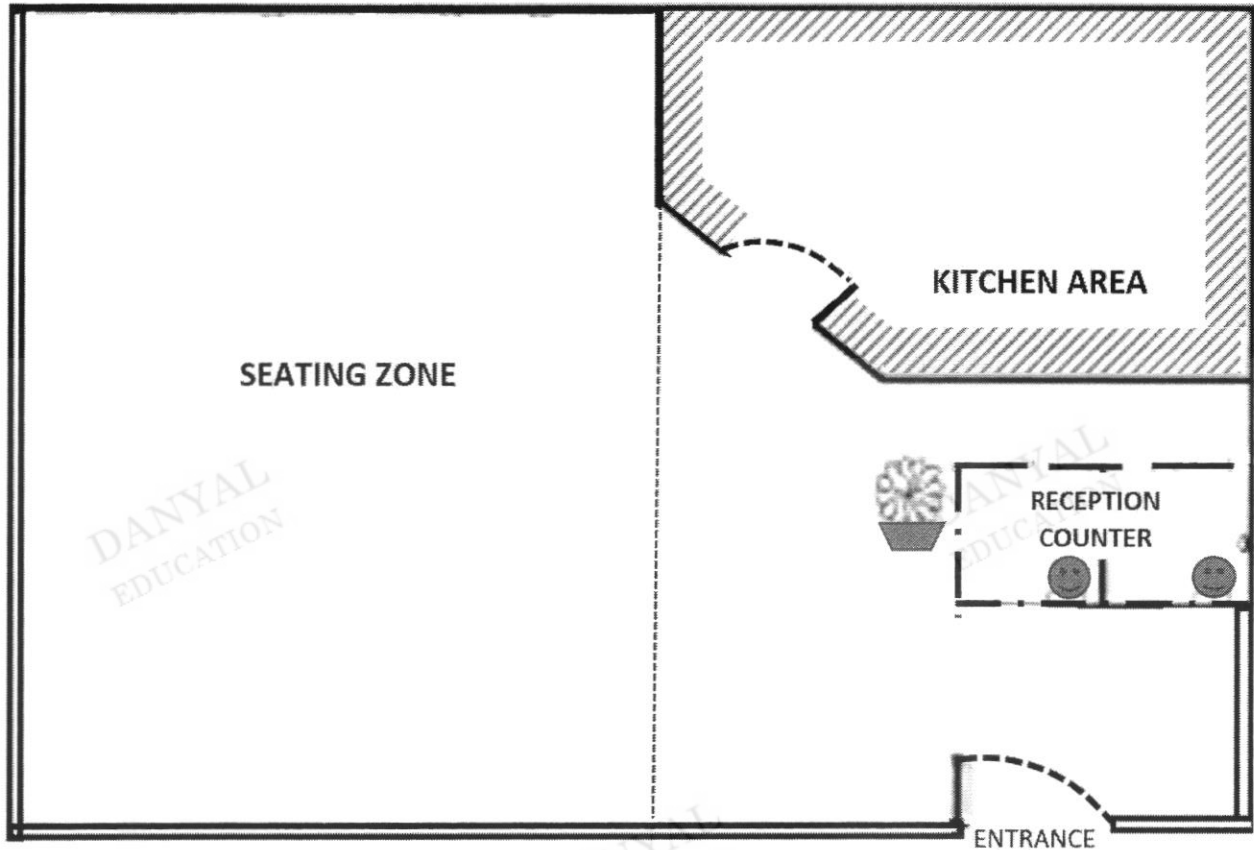
10 Christy owns a café and the floor plan is shown below.



Legend



-  Wall
-  Floor to ceiling glass panels

Scale 1 cm : 2 m

The floor of the demarcated **seating zone** is covered in tiles.

Christy decides to renovate her café by **changing** all the floor tiles and repaint the walls in the seating zone and the ceiling of the whole café.

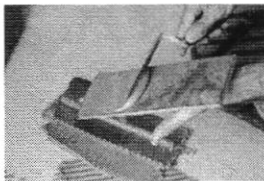
Information on floor tiles, paint and other charges for renovation is shown in the table on the next page.

Information on Floor Tiles (inclusive of 7% Goods and Services Tax)			
Cost of Floor Tiles (sold in stacks of 8)		Choice	
	Tiles dimensions (in mm)	500×500	300×600
	Cost per stack (\$)	48	40
Cost of Thinset Mortar 	Cost of 1 bag (\$)	32.50	
	Number of bags required 	40	

Information on Paint		
Type of Paint	Odour-less Anti Mould Ceiling White (For ceiling only)	Odour-less EasyWash (For walls only)
Capacity per tin (in litres)	5	5
Area coverage (in m ²) per litre	10	13
Number of coats	2	2
Cost per tin (\$) (inclusive of 7% Goods and Services Tax)	33.20	43.50

Source: <https://www.nipponpaint.com.sg/store/product-category/interior-paints/>

Charges of Contractor for Renovation (inclusive of 7% Goods and Services Tax)				
Labour cost	Removal of existing floor tiles & paint	Installation of floor tiles	Painting of walls and ceiling	Disposal of rubbish
Cost (\$) (inclusive of Goods and Service Tax)	1800	500	1600	120

- (a) The seating zone can fit **18 sets** in the seating zone.
Calculate the total cost (inclusive of 7% Goods and Services Tax) of these 18 sets of tables and chairs which Christy intends to buy.

$$18 \times \$995 = \$17910 \quad \text{-- B1}$$

- (b) Find the floor area of the seating zone which is to be covered with new floor tiles.
Give your answer in square metres.

Solution 1

$$\text{Area} = 8.8 \times 11.2 \text{ m}^2$$

$$1 \text{ cm} : 2 \text{ m}$$

$$1 \text{ cm}^2 : 4 \text{ m}^2$$

$$\begin{aligned} \text{Area of seating zone} &= 8.8 \times 11.2 \times 4 \quad \text{--- M1: seen area computed multiply by 4} \\ &= 394.24 \text{ m}^2 \quad \text{--- A1} \end{aligned}$$

Between 394 m² and 414 m²

Solution 2

$$\text{Area} = 9 \times 11.5 \text{ m}^2$$

$$1 \text{ cm} : 2 \text{ m}$$

$$1 \text{ cm}^2 : 4 \text{ m}^2$$

$$\begin{aligned} \text{Area of seating zone} &= 9 \times 11.5 \times 4 \quad \text{--- M1: seen area computed multiply by 4} \\ &= 414 \text{ m}^2 \quad \text{--- A1} \end{aligned}$$

The ceiling height in the café is 3.5 metres high.

- (c) Calculate the total area, in square metres, of the walls in the seating zone and ceiling of the whole café, which will be repainted.

Solution 1

$$\text{Ceiling} = 17.2 \times 11.2 \times 4 \text{ m}^2 = 770.56 \text{ m}^2 \quad \text{--- M1}$$

$$\begin{aligned} \text{Wall} &= [8.8 \times 3.5 \times 2] + [2.7 \times 3.5 \times 2] \text{ m}^2 \\ &= 80.5 \quad \text{--- M1} \end{aligned}$$

$$\text{Total area} = 851.06 \text{ m}^2 \quad \text{--- A1}$$

Solution 2

$$\text{Ceiling} = 17.5 \times 11.5 \times 4 \text{ m}^2 = 805 \text{ m}^2 \quad \text{--- M1}$$

$$\begin{aligned} \text{Wall} &= [9 \times 3.5 \times 2] + [2.7 \times 3.5 \times 2] \text{ m}^2 \\ &= 81.9 \quad \text{--- M1} \end{aligned}$$

$$\text{Total area} = 886.9 \text{ m}^2 \quad \text{--- A1}$$

Between 851 m² and 887 m²

- (d) Christy decides to set aside a sum of **\$30 000** for the renovation and the new sets of tables and chairs in the café.

Explain if the sum of money is sufficient. Justify your answers and show your calculations clearly.

1.

Tiles dimension (in m)	0.5×0.5	0.3×0.6
No. of tiles needed	$\frac{394}{0.25} = 1576$ to $\frac{414}{0.25} = 1656$	$\frac{394}{0.18} = 2189.88$ Or $\frac{414}{0.18} = 2300$
No. of stacks needed	$\frac{1576}{8} \approx 197$ stacks to $\frac{1656}{8} \approx 207$ stacks	$\frac{2189.88}{8} \approx 274$ stacks or $\frac{2300}{8} \approx 288$ stacks
Cost of floor tiles	$197 \times \$48 = \9456 to $207 \times \$48 = \9936	$274 \times \$40 = \10960 $288 \times \$40 = \11520
Cost of Thinset Mortar	$40 \times \$32.50 = \1300	

From the comparison, Christy should buy the 500 mm × 500 mm tiles.

B1: Thinset Motar

B1: accurate computation of the cost of floor tiles with mention to the selected size

2.

Type of paint	Odour-less Anti Mould Ceiling White	Odour-less Easy Wash Wall
Amount of paint needed in litres	$[770.56 \times 2] \div 10$ $= 154.112 \text{ l}$ to $[805 \times 2] \div 10$ $= 161 \text{ l}$	$[81.2 \times 2] \div 13$ $= 12.492 \text{ l}$ to $[81.9 \times 2] \div 13$ $= 12.6 \text{ l}$
No. of tins needed	$154.112 \div 5 = 30.822$ ≈ 31 tins to $161 \div 5 = 32.2$ ≈ 33 tins	$12.492 \div 5 \approx 3$ tins to $12.6 \div 5 \approx 3$ tins
Cost of paint	$31 \times \$33.20 = \1029.20 to $33 \times \$33.20 = \1095.60	$3 \times \$43.50 = \130.50

M1: attempt to compute the cost for one layer of paint to both ceiling and wall or other equivalent

M2: accurate computation of the cost for two layers of paint to both ceiling and wall

3.

Charges of Contractor for Renovation (inclusive of 7% Goods and Services Tax)				
Labour cost	Removal of existing floor tiles & paint	Installation of floor tiles	Painting of walls and ceiling	Disposal of rubbish
Cost (\$) (inclusive of Goods and Service Tax)	1800	500	1600	120

\$4020**Solution 1**

From the above, the total proposed amount

$$= \$17910 + \$9456 + \$1300 + \$1029.20 + \$130.50 + \$1800 + \$500 + \$1600 + 120$$

[attempts to sum up the total costs]

$$\text{--- M1: for seen at least 3 } (\$17910 + \$1800 + \$500 + \$1600 + \$120)$$

$$\text{--- M1: for seen at least 2 from } (\$9456 + \$1300 + \$1029.20 + \$130.50) \text{ based on their calculations}$$

$$= \$33,845.70$$

Solution 2

From the above, the total proposed amount

$$= \$17910 + \$9936 + \$1300 + \$1095.60 + \$130.50 + \$1800 + \$500 + \$1600 + 120$$

[attempts to sum up the total costs]

$$\text{--- M1: for seen at least 3 } (\$17910 + \$1800 + \$500 + \$1600 + \$120)$$

$$\text{--- M1: for seen at least 2 from } (\$9936 + \$1300 + \$1095.60 + \$130.50) \text{ based on their calculations}$$

$$= \$34,392.10$$

The sum of money reserved is insufficient. Christy needs to fork out money to top up the balance.

Between \$33,932.70 and \$34,522.60