

Name:	()	Class:
 <p>GREENDALE SECONDARY SCHOOL Preliminary Examination 2023</p> <p>PHYSICS 6091/01</p> <p>Paper 1 Multiple Choice 29 August 2023 Secondary 4 Express 1 hour</p> <p>Additional Materials: Multiple Choice Answer Sheet</p>		

READ THESE INSTRUCTIONS FIRST

Write in soft pencil.

Do not use staples, paper clips, glue or correction fluid.

Write your name, class and register number on the Answer Sheet and on the Question Paper in the spaces provided.

There are **forty** questions on this paper. Answer **all** questions. For each question there are four possible answers **A, B, C** and **D**.

Choose the **one** you consider correct and record your choice in **soft pencil** on the separate Answer Sheet.

Read the instructions on the Answer Sheet very carefully.

Each correct answer will score one mark. A mark will not be deducted for a wrong answer.

Any rough working should be done in this question paper.

The use of an approved scientific calculator is expected, where appropriate.

- 3 A racing car is fitted with an electronic monitoring system. Data from the car are used to plot a speed-time graph for part of the race.

The graph is displayed on a computer screen.

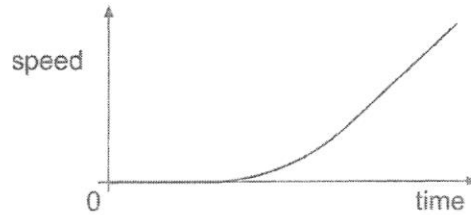

The graph covers a period of time when the car is first at rest, then

- A moving with uniform speed and then moving with uniform acceleration.
 B moving with uniform speed and then moving with non-uniform acceleration.
 C moving with uniform acceleration and then moving with non-uniform acceleration.
 D moving with non-uniform acceleration and then moving with uniform acceleration.
- 4 Forces of 4.0 N and 2.0 N act at a point.

Which scale diagram shows the forces that have a resultant of 4.0 N?

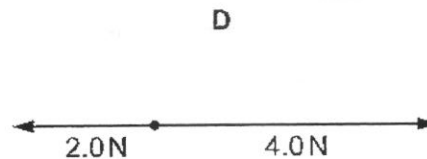
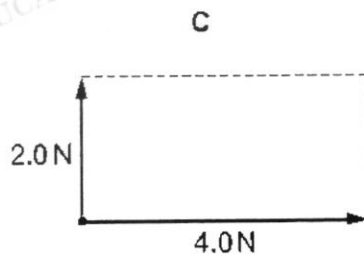
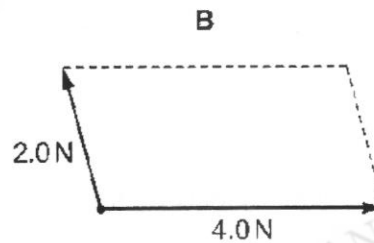
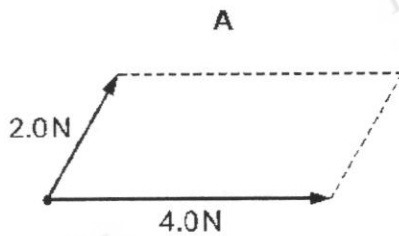

- 5 A block of wood is at rest on a sloping ramp. The forces acting on the block are the weight W of the block, the friction F between the block and the ramp and the normal force N exerted by the ramp.

Which free-body diagram is correct?

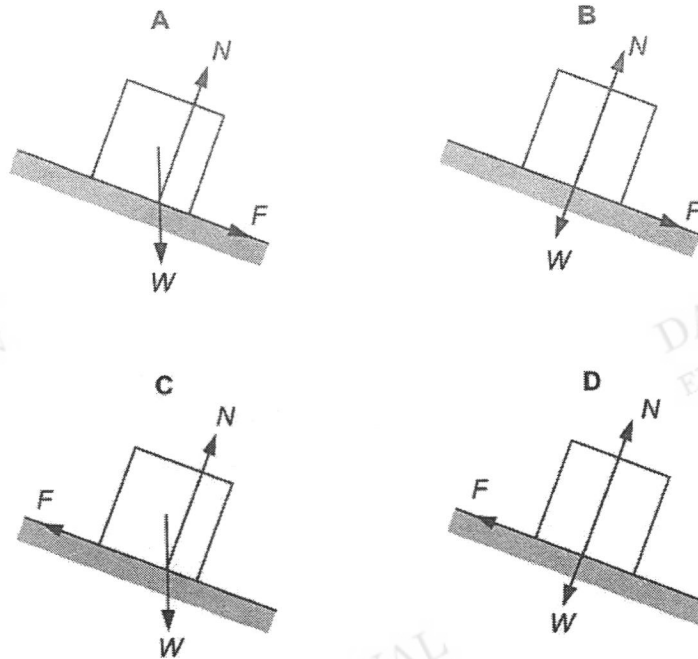

- 6 Experiments are carried out on the Moon and on Earth. There is no atmosphere on the Moon and the gravitational field strength on the Moon is less than that on Earth.

A coin and a feather are dropped at the same instant from the same height.

Which statement is correct for the experiment on the Moon?

- A The coin falls faster than the feather, but both take a longer time than on Earth.
- B The coin falls faster than the feather, but both take a shorter time than on Earth.
- C They fall together, taking a longer time than the coin takes on Earth.
- D They fall together, taking a shorter time than the coin takes on Earth.

- 7 An astronaut has a mass of 84.0 kg on the Earth where the gravitational field strength is 10 N / kg.

He goes to Mars where the field strength is 38% of that on the Earth.

Which row is correct?

	mass on Mars / kg	weight on Mars / N
A	31.9	121
B	31.9	319
C	84.0	319
D	84.0	840

- 8 Water is added to a measuring cylinder containing 100 cm³ of liquid paraffin.

The density of paraffin is 0.80 g/cm³ and that of the water is 1.0 g/cm³.

As the water is added, the level of the paraffin rises to 150 cm³. The paraffin and water do not mix.

What finally is the total mass of liquid in the measuring cylinder?

- A** 130 g **B** 140 g **C** 167 g **D** 175 g
- 9 A uniform rod of weight 5.0 N is held initially at rest.

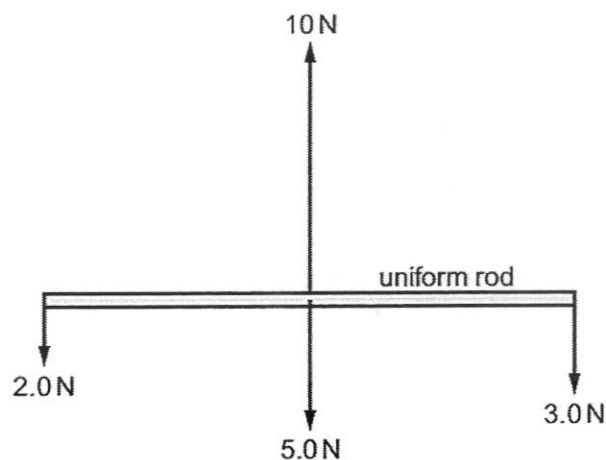

What happens to the rod when it is released?

- A** It does not move.
B It moves to the right.
C It moves upwards.
D It starts to rotate.

- 10 Work is done when a force of 400 N pulls a crate of weight 500 N at a constant speed along a ramp, as shown.

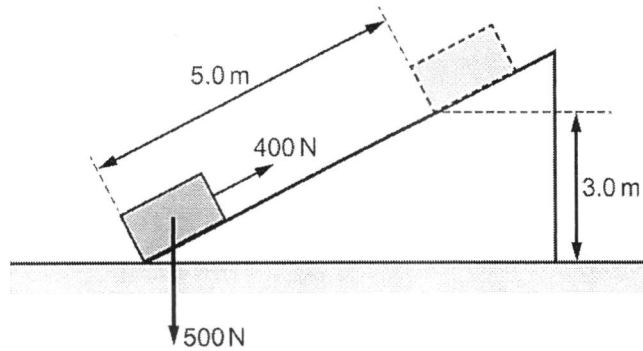

Part of the work done increases the gravitational potential energy E of the crate and the rest is work done W against friction.

What are the values of E and W ?

	E / J	W / J
A	1500	500
B	1500	2000
C	2000	2500
D	3500	500

- 11 Five blocks have the same mass but different base area. They all rest on a horizontal table.

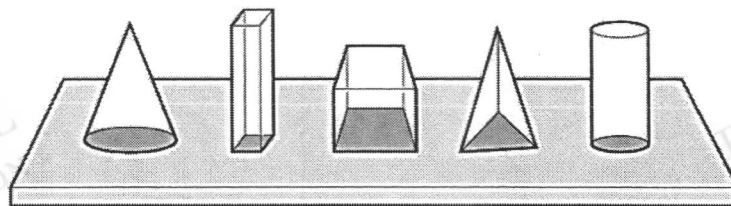

A graph is plotted to show the relationship between the pressure exerted on the table and the base area of the block.

Which graph shows the relationship?

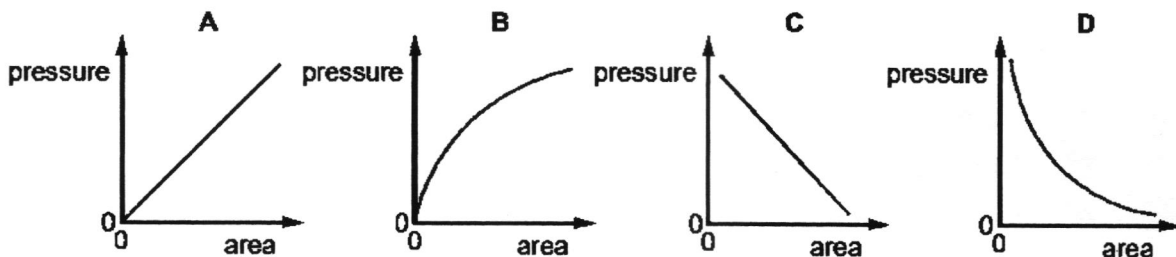

- 12 Four submarines are submerged. The density of fresh water is 1000 kg/m^3 and the density of sea water is 1020 kg/m^3 .

Which submarine experiences the greatest pressure due to the water?

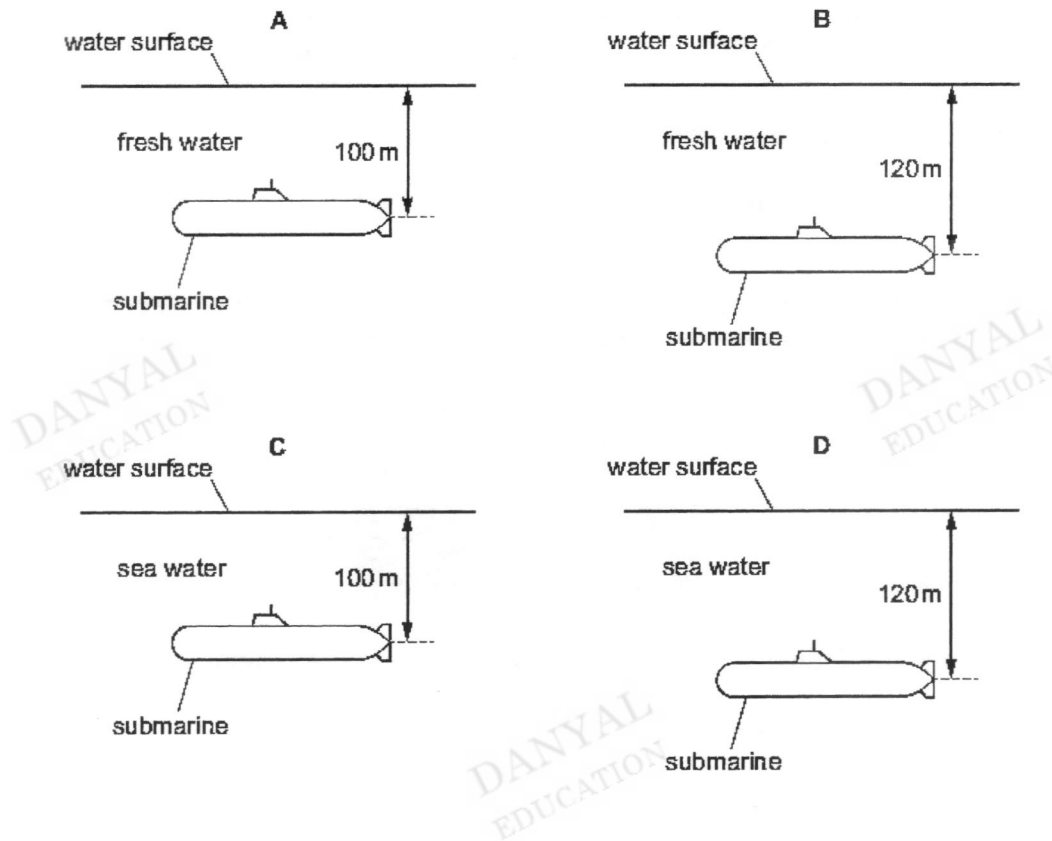

- 13 The diagram shows a simple mercury barometer.

Which height is a measure of the atmospheric pressure?

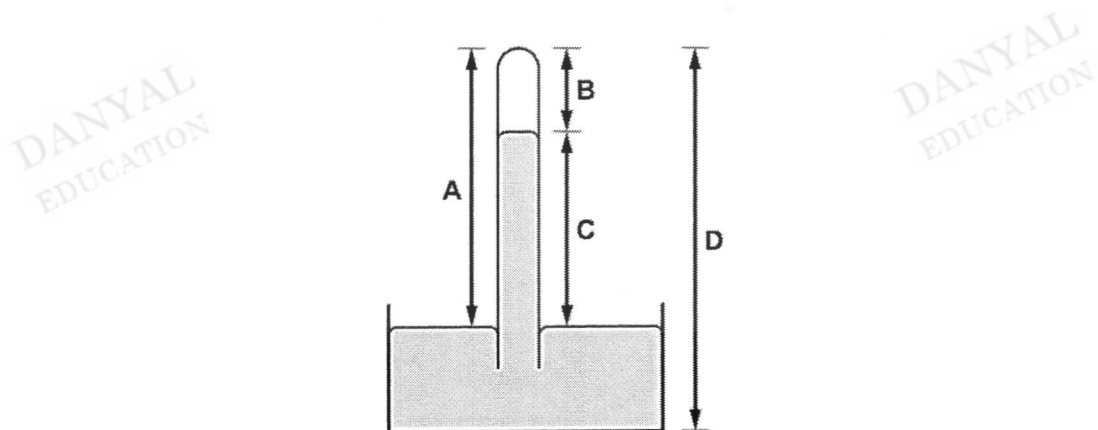

- 14 The resistance R of a wire increases uniformly with temperature. The values of R at the fixed points are shown in the table.

	0 °C	100 °C
R / Ω	100	250

What is the temperature when $R = 160 \Omega$?

- A 24 °C B 40 °C C 60 °C D 64 °C
- 15 A thermocouple thermometer uses a voltmeter to measure the electromotive force (e.m.f.) generated between two junctions. The junctions are at temperatures T_1 and T_2 .

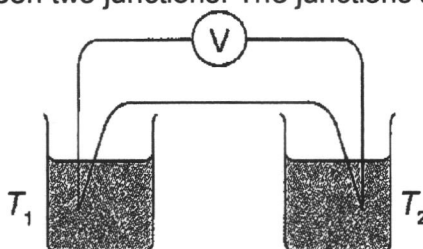

Which pair of values of T_1 and T_2 produces the smallest voltmeter reading?

	value of $T_1 / ^\circ\text{C}$	value of $T_2 / ^\circ\text{C}$
A	20	40
B	20	80
C	60	100
D	100	125

- 16 When a piece of smouldering rope is held at the opening of the box in the diagram, smoke moves in the direction indicated.

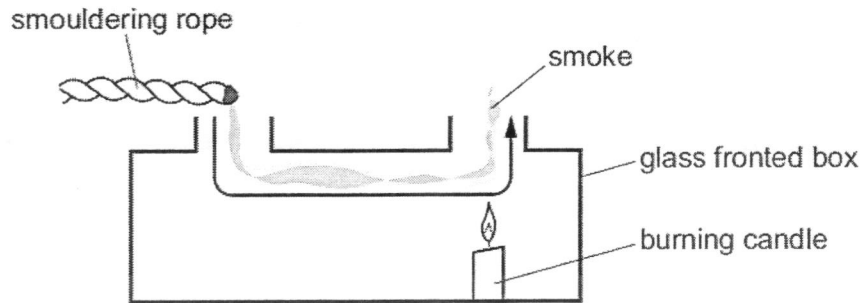

What is responsible for the movement of the smoke?

- A convection
 B movement of free electrons
 C radiation
 D vibration of molecules
- 17 The diagram shows four beakers **A**, **B**, **C** and **D**. The beakers contain different amounts of the same liquid at the same temperature. The beakers are left next to each other on a laboratory bench overnight. The diagrams are all drawn to the same scale.

From which beaker does the largest quantity of liquid evaporate?

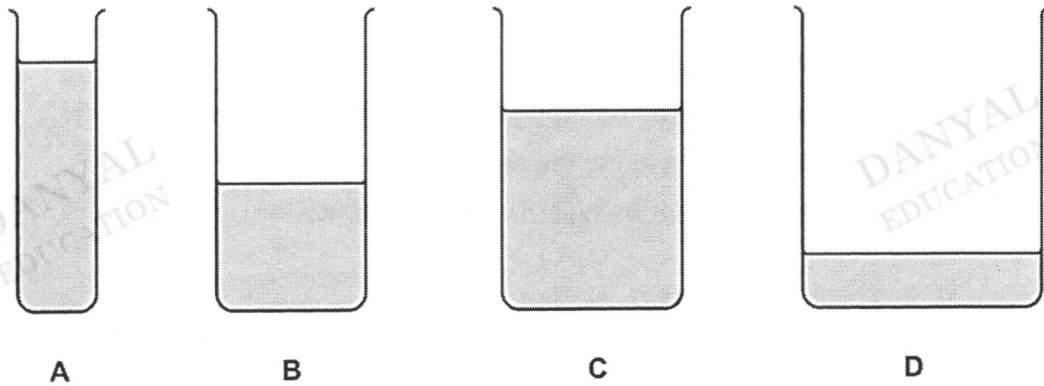

- 22** When sections of a large metal pipe have been welded together, they are checked to discover whether there are any cracks in the joints.

Which component of the electromagnetic spectrum is used for this purpose?

- A** infra-red waves **B** radiowaves
C ultra-violet waves **D** X-rays
- 23** Which waves consist of compressions and rarefactions?
- A** gamma rays **B** infra-red waves
C radio waves **D** ultrasound waves
- 24** A student stands 50 m from a wall and knocks two wooden blocks together. When the frequency of knocking is 3 knocks per second, the echo of a knock is heard at the instant of the next one.

What is the speed of sound calculated using these measurements?

- A** 150 m/s **B** 200 m/s **C** 300 m/s **D** 350 m/s
- 25** The diagram shows the trace on a cathode-ray oscilloscope when a microphone which is connected to it picks up a sound.

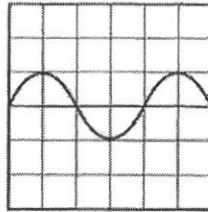

Which trace is obtained when the sound wave is changed to one of higher pitch but the same loudness?

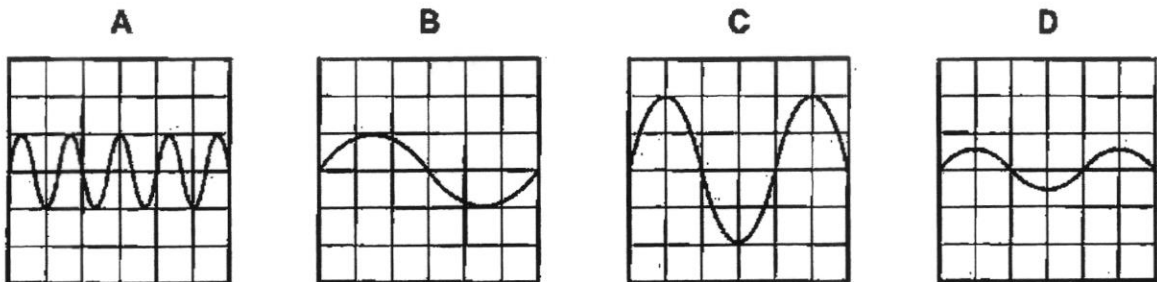

- 26 To fully charge a battery for a portable electric saw, a current of 3.0 A is used for five hours.

How much charge does the battery store?

- A 15 C B 900 C C 6000 C D 54 000 C

- 27 A copper wire X has resistance R . Another copper wire Y has twice the length and half the cross-sectional area of wire X.

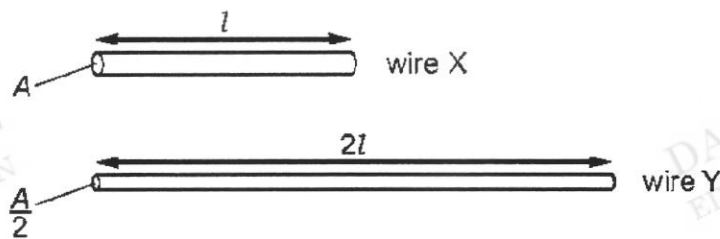

What is the resistance of wire Y?

- A $R/2$ B R C $2R$ D $4R$

- 28 The diagram shows two resistors, of resistance R_1 and R_2 , used as a potential divider.

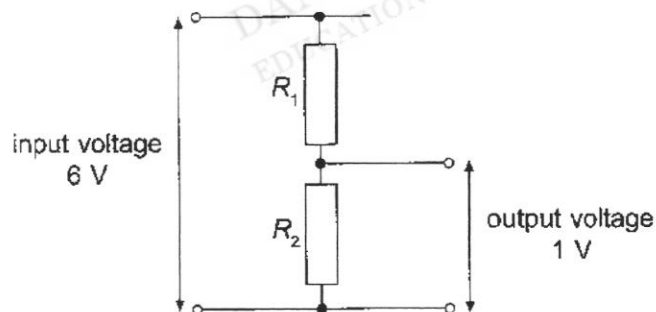

The input voltage is 6 V.

Which pair of values for the resistances R_1 and R_2 gives an output voltage of 1 V?

	R_1 / Ω	R_2 / Ω
A	1	5
B	1	6
C	5	1
D	6	1

- 29 A thermistor and a light-dependent resistor are connected in series.

Which conditions give the smallest resistance?

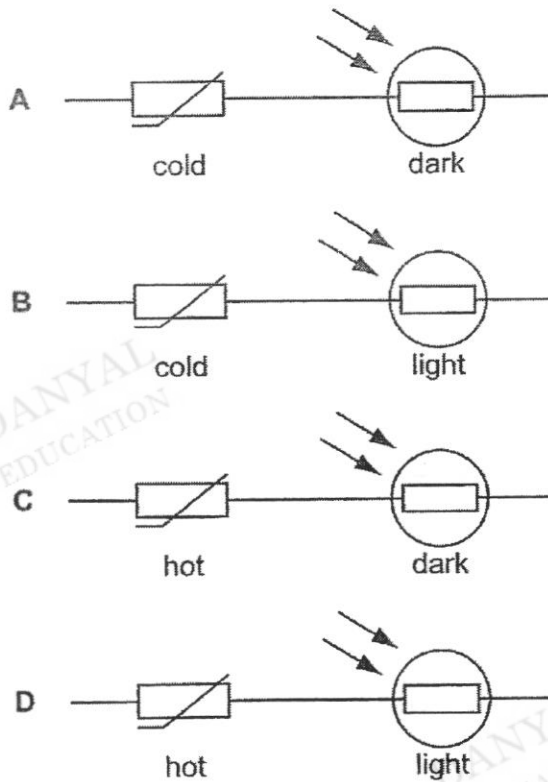

- 30 The circuit diagram shows a $1.0\ \Omega$ resistor connected in series with a parallel arrangement of a $1.0\ \Omega$ resistor and a $2.5\ \Omega$ resistor.

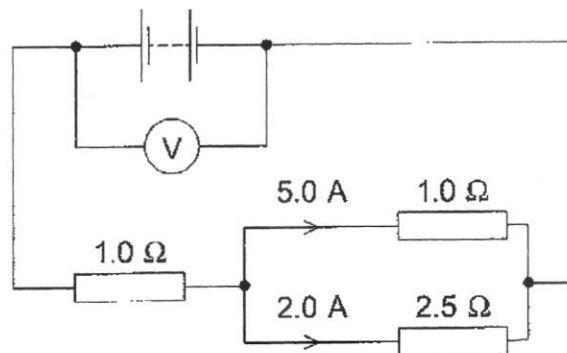

The currents in the two parallel resistors are shown.

What is the reading on the voltmeter?

- A 7.0 V B 10 V C 12 V D 17 V

- 31** The diagram shows six identical lamps, four ammeters and a battery.
 The current in the battery is 1.5 A.
 Which ammeter reads 1.0 A?

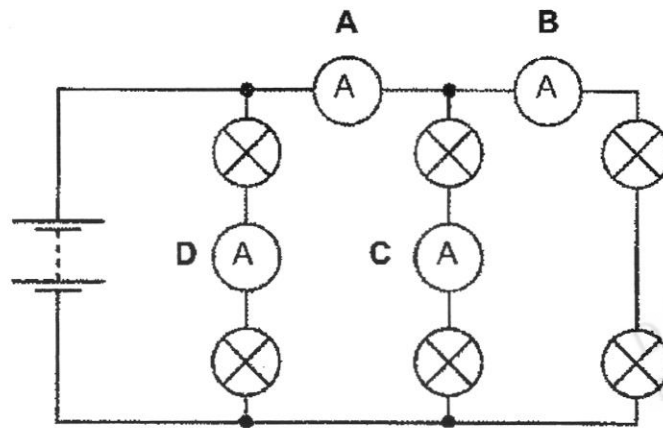

- 32** The wiring for a home appliance includes a switch and a fuse.
 Where are these located?

	switch	fuse
A	live wire	live wire
B	live wire	neutral wire
C	neutral wire	live wire
D	neutral wire	neutral wire

- 33** Two bar magnets are placed near each other with their poles as shown. A student plots the resultant magnetic field with a compass. The Earth's magnetic field can be ignored.
 At which point does the compass point towards the top of the page?

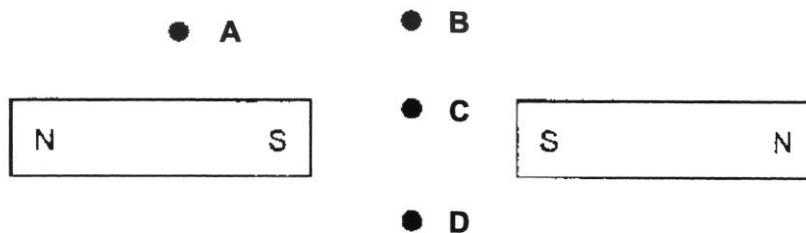

34 Which diagram shows the most effective method of demagnetizing a permanent magnet?

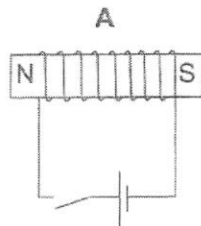

current switched on then off, with magnet left in place

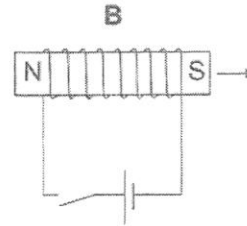

current switched on, then magnet withdrawn

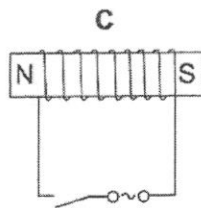

current switched on then off, with magnet left in place

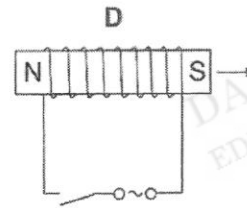

current switched on, then magnet withdrawn

35 Which metals are used for temporary and for permanent magnets?

	temporary	permanent
A	iron	copper
B	iron	steel
C	copper	iron
D	steel	iron

- 36 The diagram shows an alarm system.

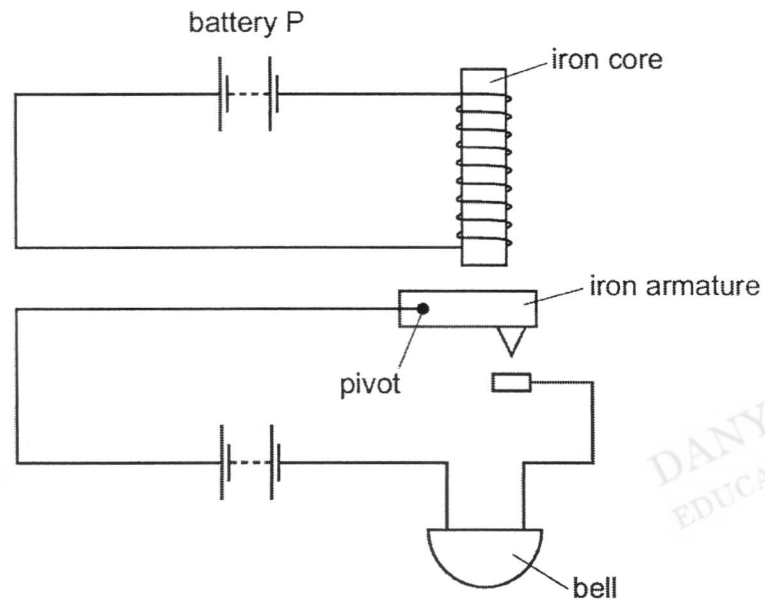

What happens when battery P is disconnected?

	iron armature	bell
A	falls	rings
B	falls	stops ringing
C	moves up	rings
D	moves up	stops ringing

- 37 A horizontal beam of electrons passes between the two poles of a magnet.

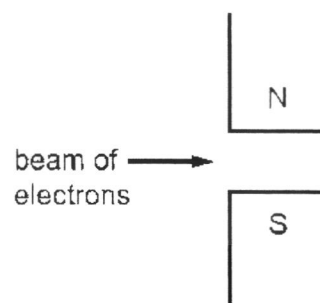

In which direction is the beam deflected?

- A** into the page
- B** out of the page
- C** towards the north pole
- D** towards the south pole

- 38** There is an upward current in a vertical wire XY. This produces a magnetic field in the region and around XY.

Which diagram shows the pattern of magnetic field lines produced by the current?

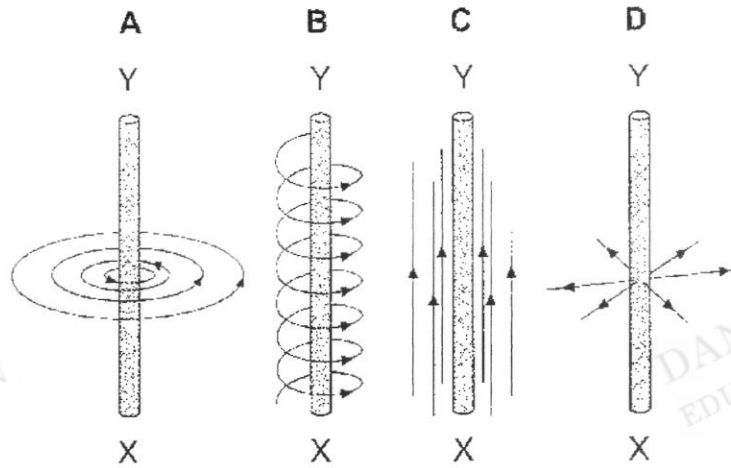

- 39** A solenoid is connected in series with a sensitive ammeter. The N pole of a magnet is placed next to one end of the solenoid, marked X.

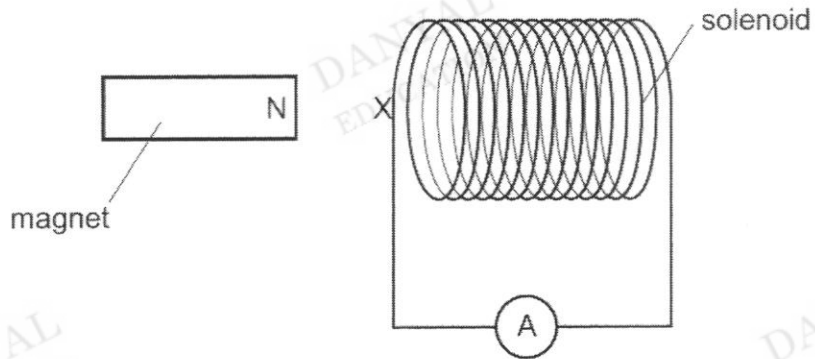

First, the N pole of the magnet is pushed towards X, then the magnet is pulled away from X. During both stages the ammeter deflects.

Which type of magnetic pole is induced at X during these two stages?

	as N pole moves towards X	as N pole moves away from X
A	N pole	N pole
B	N pole	S pole
C	S pole	N pole
D	S pole	S pole

40 The diagram shows a simple a.c. generator.

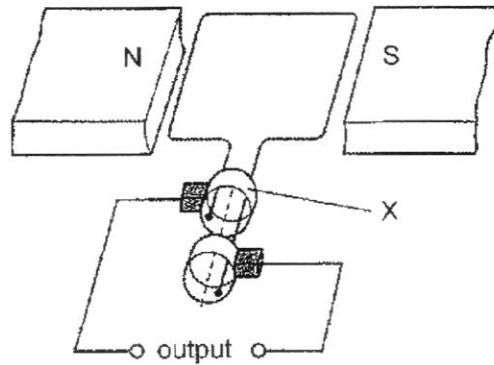

What is component X?

- A carbon brush
- C commutator

- B coil
- D slip ring

END OF PAPER

Name: _____ ()	Class: _____
 <p style="font-size: 1.2em; font-weight: bold; margin: 10px 0;">GREENDALE SECONDARY SCHOOL</p> <p style="font-size: 1.1em; margin: 0 0 10px 0;">Preliminary Examination 2023</p> <div style="display: flex; justify-content: space-between; align-items: flex-start; margin-top: 20px;"> <div style="width: 45%;"> <p style="font-weight: bold; margin: 0;">PHYSICS</p> <p style="margin: 5px 0;">Paper 2 Theory Secondary 4 Express</p> <p style="margin: 10px 0 0 0;">Candidates answer on the Question Paper No Additional Materials are required</p> </div> <div style="width: 45%; text-align: right;"> <p style="font-weight: bold; margin: 0;">6091/02</p> <p style="margin: 5px 0;">22 August 2023 1 hour 45 minutes</p> </div> </div>	

READ THESE INSTRUCTIONS FIRST

Write your class, register number and name on all the work you hand in.
Write in dark blue or black pen.
You may use an HB pencil for any diagrams or graphs.
Do not use staples, paper clips, glue or correction fluid.

Section A
Answer **all** questions.

Section B
Answer **all** questions. Question 12 has a choice of parts to answer.

Candidates are reminded that **all** quantitative answers should include appropriate units.
The use of an approved scientific calculator is expected, where appropriate.
Candidates are advised to show all their working in a clear and orderly manner, as more marks are awarded for sound use of Physics than for correct answers.

At the end of the examination, fasten all your work securely together.
The number of marks is given in brackets [] at the end of each question or part question.

For Examiner's Use	
Paper 1	/ 40
Paper 2 Section A	/ 50
Paper 2 Section B	/ 30
Total	/ 120

This document consists of **22** printed pages.

[Turn over

Section A

Answer **all** the questions in this section.

- 1 A large plastic ball is dropped vertically downwards from the top of a tall building.

Fig. 1.1 shows the velocity–time graph for the falling ball until it hits the ground.

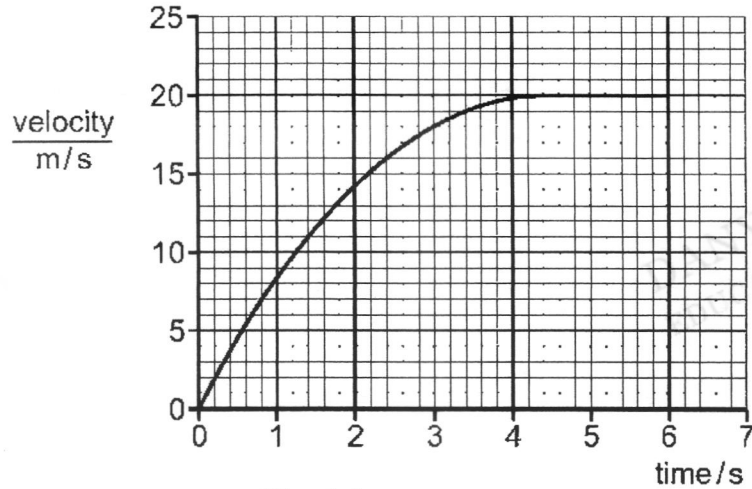

Fig. 1.1

- (a) Estimate the change in displacement of the ball while it is falling with terminal velocity.

change in displacement = [2]

- (b) Use Newton's laws of motion to explain why the ball accelerates at first and then reaches terminal velocity.

.....

 [3]

- (c) The weight of the ball is one of the two forces that form an action-reaction pair of forces.

Describe the other force of this pair.

..... [1]

[Total: 6]

- 2 A passenger in an aircraft closes a plastic bag with some air inside, as shown in Fig. 2.1.

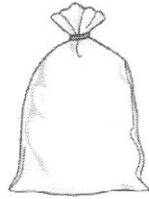

Fig. 2.1

- (a) Explain how the molecules of air in the bag exert a pressure on the inside of the bag.

.....

 [2]

- (b) When the bag is closed, the pressure of the air inside the aircraft is 80 kPa and the bag contains 500 cm³ of air.

- (i) When the aircraft is on the ground, the pressure of the air inside the aircraft is 100 kPa.

Calculate the volume of air inside the bag when the aircraft is on the ground.

DANYAL EDUCATION

DANYAL EDUCATION

volume = [2]

- (ii) State two assumptions that you made in your calculation in (b)(i).

1.

 2.
 [2]

[Total: 6]

- 3 A curved, glass tube is open at one end and sealed at the other. A dense liquid is poured into the tube. The liquid traps air in the sealed end.

Fig. 3.1 shows the tube, the liquid and the trapped air.

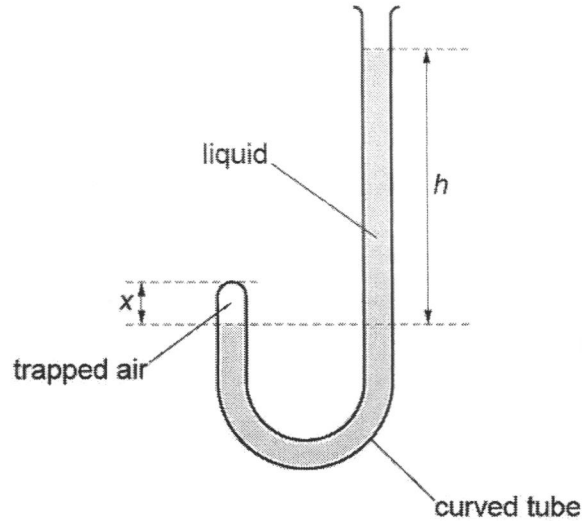

Fig. 3.1

- (a) The difference between the liquid levels is h . At room temperature, h is 0.57 m.

The atmospheric pressure is 1.0×10^5 Pa and the gravitational field strength g is 10 N/kg. The density of the liquid is 1.4×10^4 kg/m³.

Calculate the pressure of the trapped air.

pressure = [3]

3 (b) The trapped air in the tube is heated.

The height of the trapped air in the tube is x .

Explain, in terms of molecules, why x changes when the air is heated.

.....

.....

.....

.....

.....[3]

[Total: 6]

DANYAL
EDUCATION

DANYAL
EDUCATION

DANYAL
EDUCATION

DANYAL
EDUCATION

DANYAL
EDUCATION

- 4 Fig. 4.1 shows a model of the human arm. The rubber band represents the muscle that moves part of the arm XY up.

A mass is suspended from XY, as shown in Fig. 4.2. The weight of section XY is negligible and the model is at rest.

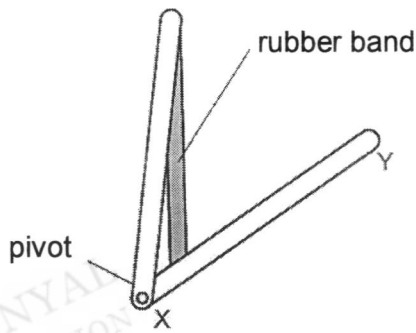

Fig. 4.1

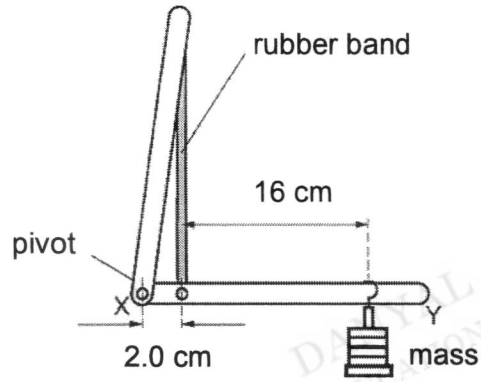

Fig. 4.2 (not to scale)

- (a) State the principle of moments.

.....

[2]

- (b) Explain why the force that the rubber band exerts on section XY is larger than the weight of the mass.

.....
[1]

- (c) The mass suspended from section XY in Fig. 4.2 has a weight of 4.0 N.

Calculate the force that the rubber band exerts on section XY.

force = [2]

- (d) Explain how your answer to (c) is different if the weight of section XY is **not** negligible.

.....
[1]

[Total: 6]

5 One form of latent heat is the thermal energy needed to melt a solid.

(a) Define *specific latent heat*.

.....
.....
..... [2]

(b) Fig. 5.1 shows one method of measuring the thermal energy needed to melt ice. The ice is contained in a glass funnel and covered with an insulator.

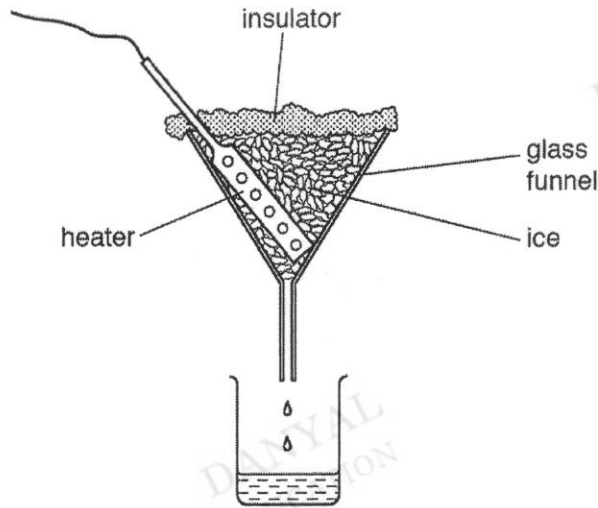

Fig. 5.1

(i) The heater is switched on and the ice melts.

The specific latent heat of fusion of ice is 3.3×10^5 J/kg.

Calculate the energy needed to melt 5.0 g of ice.

energy = [2]

(ii) Before the heater is switched on, thermal energy from the room causes some of the ice to melt.

Describe the process by which the ice gains thermal energy from the air.

.....
..... [1]

[Total: 5]

- 6 An object **O** is placed 25.0 cm in front of a thin converging lens, as shown in the ray diagram of Fig. 6.1.

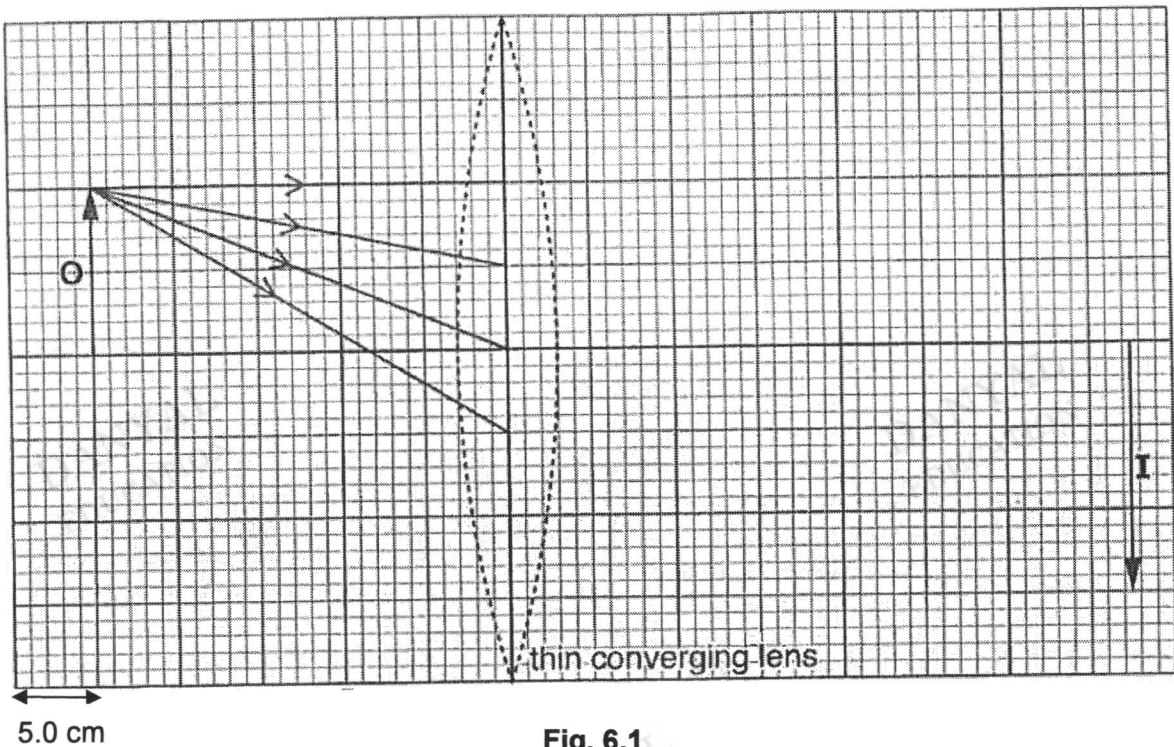

Fig. 6.1

The lens forms an image **I** of the object **O**, as shown in Fig. 6.1.

- (a) The image formed is inverted and magnified. State one other property of this image.

.....[1]

- (b) Complete the four rays from the top of the object to show the formation of the image. [2]

- (c) Determine the focal length of the lens.

focal length = [1]

[Total: 4]

7 Electrostatics can be a nuisance but is also useful.

- (a) A person walks across a carpet. As he touches a door handle he receives an electric shock.

Suggest why this happens.

.....

.....

..... [2]

- (b) In spray painting, small drops of paint with a positive charge emerge from a nozzle. The drops are used to paint the leg of a metal chair, which has a negative charge, as shown in Fig. 7.1.

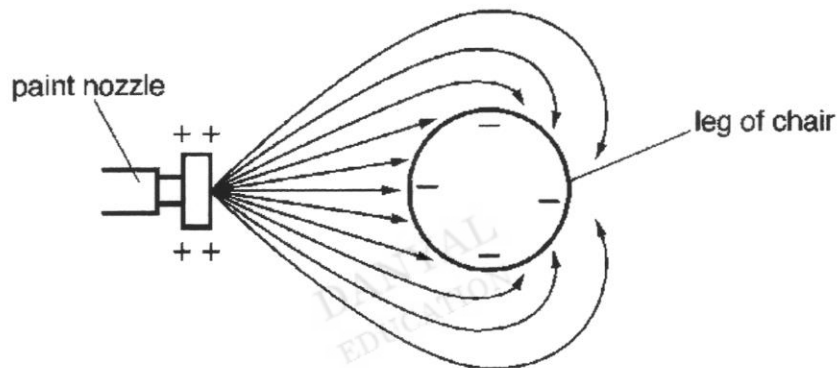

Fig. 7.1 (not to scale)

Fig. 7.2 shows what happens when there is no charge on the nozzle, or on the drops or on the leg of the chair.

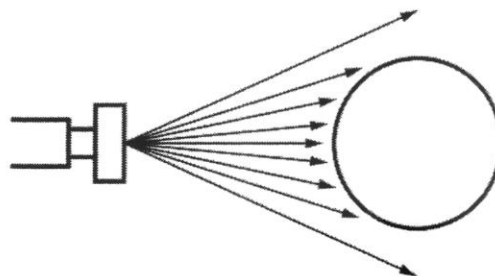

Fig. 7.2 (not to scale)

- 7 (b) (i) The drops in Fig. 7.1 spread out more as they leave the nozzle than those in Fig. 7.2.

Explain why.

.....
..... [2]

- (ii) Explain why the paint reaches the back of the leg in Fig. 7.1.

.....
..... [1]

[Total 5]

DANYAL
EDUCATION

DANYAL
EDUCATION

DANYAL
EDUCATION

DANYAL
EDUCATION

DANYAL
EDUCATION

8 Wind energy is a renewable energy source. A wind turbine and generator convert energy in the wind to electrical energy in a generator. Fig. 8.1 shows some wind turbines.

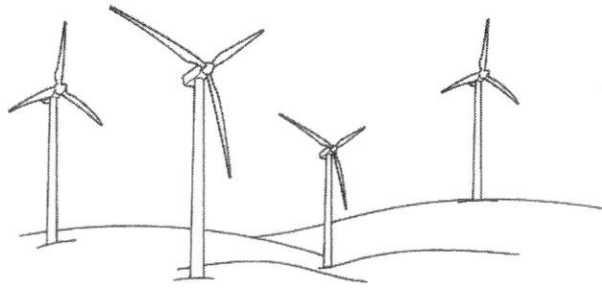

Fig. 8.1

(a) State the name of **one other** renewable energy source.

.....[1]

(b) During a 30-minute period, a mass of 4.2×10^7 kg of air enters the turbine with a speed of 15 m/s.

(i) Calculate the kinetic energy of the air that enters the turbine in 30 minutes.

kinetic energy =[2]

(ii) The electrical power output of the generator to the turbine is 8.4×10^5 W.

Calculate the electrical energy output from the turbine in 30 minutes.

energy output =[2]

(iii) Calculate the efficiency of the turbine and generator in converting the kinetic energy of the air to electrical energy.

efficiency =[2]

[Total 7]

9 A student uses the circuit shown in Fig. 9.1 to investigate a resistor R.

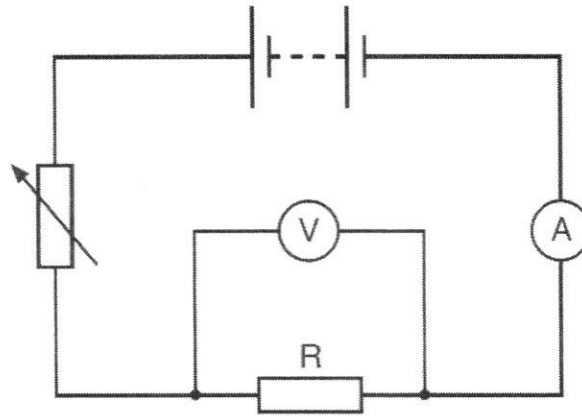

Fig. 9.1

(a) Describe how the student uses the apparatus in Fig. 9.1 to obtain a range of ammeter and voltmeter readings.

.....
 [1]

(b) The readings obtained are shown in Table 9.1.

Table 9.1

voltmeter reading/ V	ammeter reading/ mA
7.6	320
5.2	220
2.4	100

(i) State Ohm's law.

.....

 [2]

(ii) Using the results in Table 9.1, show that the resistor obeys Ohm's law.

.....
 [1]

9 (b) (iii) The student has available an ammeter with five ranges marked:

- 0 – 10 A
- 0 – 200 mA
- 0 – 20 mA
- 0 – 2 mA
- 0 – 0.2 mA

Suggest how the student makes best use of the different ranges during the investigation.

.....

.....

..... [1]

[Total 5]

Section B

Answer **all** the questions in this section.

Answer only one of the two alternative questions in **Question 12**.

10 (a) (i) Describe two differences between boiling and evaporation.

1.

.....

2.

.....[2]

(ii) Explain, using ideas about molecules, why thermal energy is needed to boil a liquid.

.....

.....

.....

.....[2]

(b) In one type of bathroom shower, cold water passes through a metal pipe which contains an electric heater.

The cold water is heated and emerges from the shower head.

The temperature of the cold water before heating is measured and the hot water emerging from the shower in 1.0 minute is collected in a container.

Measurements and other data are:

temperature of water before heating = 16 °C

temperature of water after heating = 37 °C

volume of water collected in 1.0 minute = $4.6 \times 10^{-3} \text{ m}^3$

specific heat capacity of water = 4200 J/(kg °C)

density of water = 1000 kg/m³

(i) Calculate the mass of water leaving the shower in 1.0 s.

mass =[2]

10 (b) (ii) Calculate the thermal energy (heat) gained by the water in 1.0 s.

thermal energy =[3]

(iii) The metal pipe that contains the electric heater is earthed.

Explain why this is necessary.

.....
.....
.....
.....[1]

[Total 10]

DANYAL
EDUCATION

DANYAL
EDUCATION

DANYAL
EDUCATION

DANYAL
EDUCATION

DANYAL
EDUCATION

11 Fig. 11.1 shows a multi-mode optical fibre made from glass of uniform refractive index.

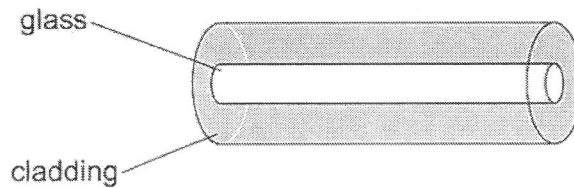

Fig. 11.1

Fig. 11.2 shows three rays of light entering the fibre from the air. Each of these rays follows one of the three possible paths through the fibre.

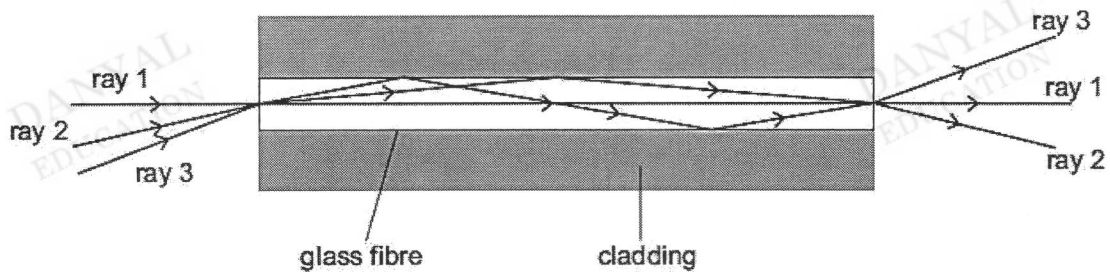

Fig. 11.2 (not to scale)

The three rays travel different distances and take different times to pass through the fibre.

Fig. 11.3 gives information about the three rays and their paths in a 1 km and a 2 km cable.

	angle of incidence on entry / °	angle of refraction on entry / °	distance covered in 1 km cable / m	time spent in 1 km cable / μs	distance covered in 2 km cable / m	time spent in 2 km cable / μs
ray 1	0	0	1000	5.0	2000	10.0
ray 2	20	13	1027	5.1	2054	10.3
ray 3	35	X	1082	5.4	2164	10.8

Fig. 11.3

- (a) Using data for ray 1 from Fig. 11.3, calculate the refractive index of the glass. The speed of light in air is 3.0×10^8 m/s.

refractive index = [2]

11 (b) Calculate the angle of refraction X for ray 3.

angle = [2]

(c) At time $t = 0$, a single pulse of light enters an optical fibre of length 2 km. The pulse lasts $0.1 \mu\text{s}$. Fig. 11.4 shows the pulses of light that leave the fibre.

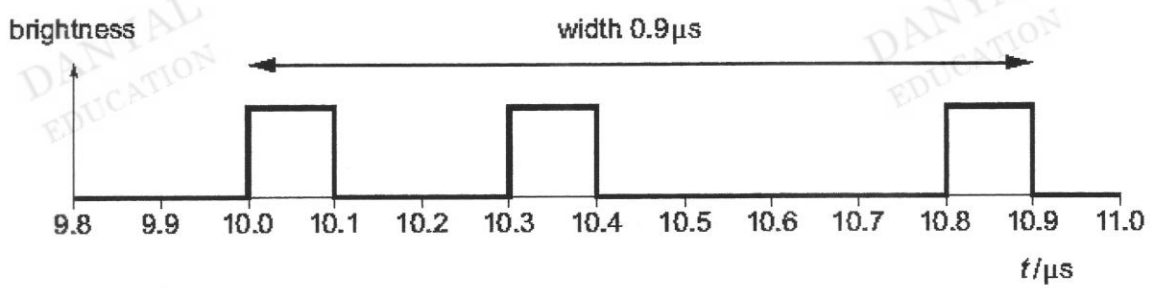

Fig. 11.4

(i) Using data from Fig. 11.3, explain Fig. 11.4.

.....

 [1]

(ii) At $t = 0$, a single pulse of light enters an optical fibre of length 1 km. This pulse also lasts $0.1 \mu\text{s}$.

On Fig. 11.5, draw the pulses of light that leave the fibre. [2]

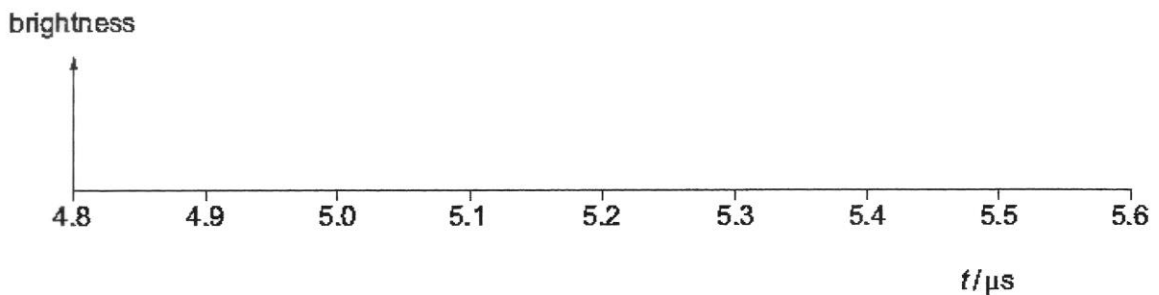

Fig. 11.5

11 (c) (iii) Fig. 11.4 shows that a pulse of light, lasting $0.1 \mu\text{s}$ when it enters the 2 km optical fibre, becomes three pulses lasting in total $0.9 \mu\text{s}$ that leave the fibre.

In a telephone conversation, a series of pulses is sent along an optical fibre.

It is important that no light from one pulse overlaps light from the next pulse.

A second pulse of $0.1 \mu\text{s}$ must enter the fibre at least $0.9 \mu\text{s}$ after the first.

Estimate the maximum number of pulses of light that can enter the 2 km optical fibre in one second.

number of pulses in one second = [2]

(iv) Explain why multi-mode optical fibres are **not** used to transmit data at high rates over very long distances.

.....
.....
.....[1]

[Total: 10]

12 EITHER

- (a) Fig. 12.1 shows a circuit. The circuit includes three resistors and two open switches S_1 and S_2 .

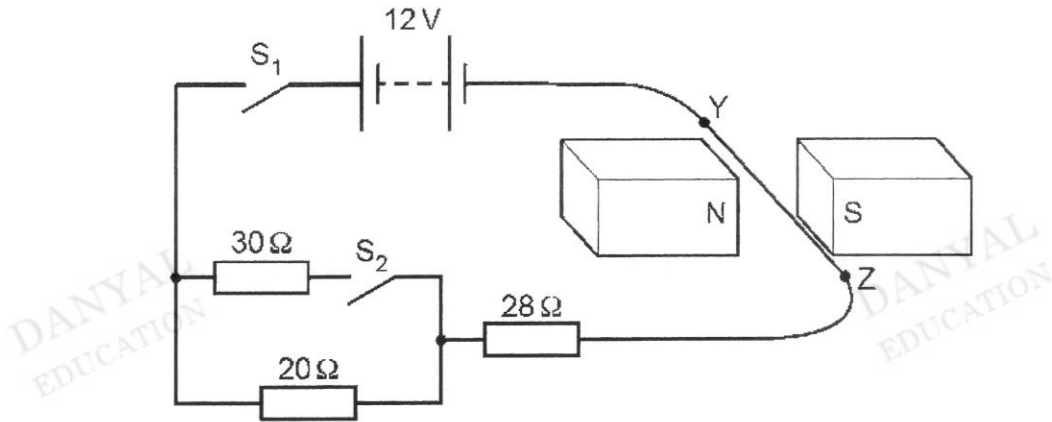

Fig. 12.1

YZ is a straight, horizontal section of connecting wire that lies between two magnets.
 S_1 is now closed.

- (i) Calculate the current in YZ.

current = [2]

- (ii) Explain why YZ experiences a force.

.....
[1]

- (iii) Explain how the direction of the force on YZ is determined.

.....

[3]

12 (b) Switch S_2 in the circuit in Fig. 12.1 is now also closed.

(i) Calculate the total resistance of the circuit.

total resistance = [2]

(ii) Explain what happens to the force on YZ as switch S_2 is closed.

.....
.....
..... [2]

[Total: 10]

DANYAL
EDUCATION

DANYAL
EDUCATION

DANYAL
EDUCATION

DANYAL
EDUCATION

DANYAL
EDUCATION

OR

- 12 Fig. 12.1 shows a transformer connecting an overhead 25 000 V electrical power line to a house.

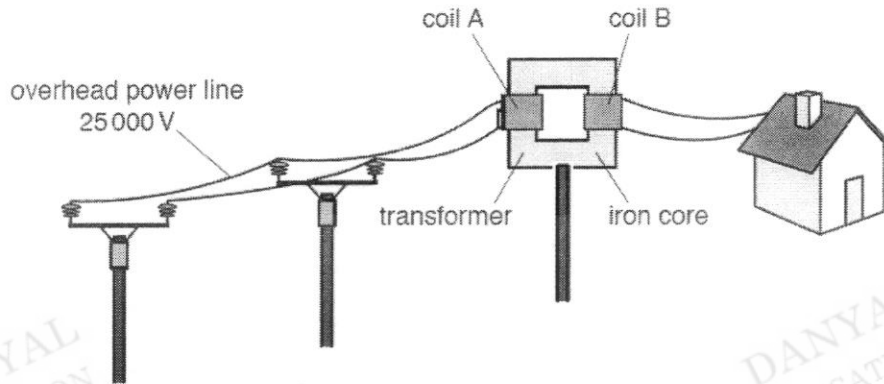

Fig. 12.1 (not to scale)

- (a) State whether coil A or coil B in the transformer has the larger number of turns.

Give a reason for your answer.

.....
[1]

- (b) One purpose of using an iron core in the transformer is to increase the magnetic field inside coil A.

State one **other** purpose of using the iron core.

.....
[1]

- (c) Describe briefly how an output voltage is induced in coil B.

.....

[1]

- (d) The voltage supplied to the house is 250 V. The number of turns in coil A is 5000.

Calculate the number of turns in coil B.

number of turns = [2]

- 12 (e) The generator that supplies the electric power contains a coil that rotates between the poles of a magnet.

The coil rotates 50 times in one second and produces an alternating voltage output with a maximum value of 500 V.

- (i) On the grid in Fig. 12.2, sketch a voltage–time graph showing the output voltage. [2]

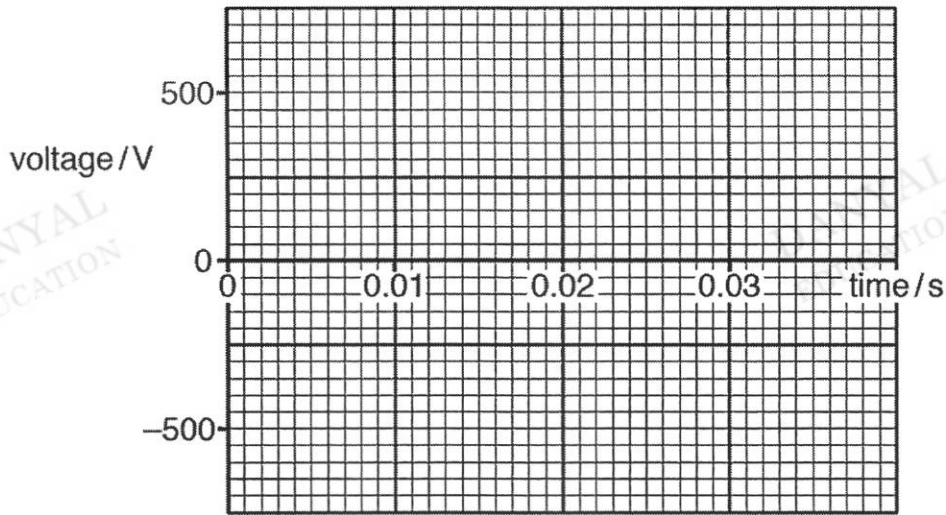

Fig. 12.2

- (ii) The output voltage from the generator is stepped up by a transformer. The electrical energy then passes along a transmission line to a distant house.

Explain why

1. a high voltage is used for the transmission of electrical energy,

.....

[2]

2. a transformer is used to connect the transmission line to the house.

.....
[1]

[Total 10]

4E Pure Physics
Prelim 2023
Marking Scheme

Paper 1

1	2	3	4	5	6	7	8	9	10
B	C	D	B	C	C	C	A	D	A
11	12	13	14	15	16	17	18	19	20
D	D	C	B	A	A	D	D	D	A
21	22	23	24	25	26	27	28	29	30
D	D	D	C	A	D	D	C	D	C
31	32	33	34	35	36	37	38	39	40
A	A	B	D	B	A	B	A	B	D

Paper 2 Section A

Qn	Answer	Mark
1(a)	d = (area under graph) = 20.0×2.0 = 40 m (2 sf)	[1] [1]
1(b)	The ball starts from rest, and there is negligible/ no air resistance . AND Resultant force is the weight of the ball. OR $F = ma$, ball accelerates (gravitational acceleration = 10 m/s^2)	[1]
	As its speed increases, air resistance increases . Hence resultant force decreases ($F_R = W - A.R.$), and acceleration decreases .	[1]
	Eventually at terminal velocity, air resistance is equal to weight AND resultant force becomes zero, OR forces are balanced, hence there is no acceleration.	[1]
1(c)	Force of ball on Earth AND equal and opposite direction	[1]
TOTAL		[6]
2(a)	Air molecules in the bag are moving randomly and continuously .	[1]
	As it collides with the (inside of the) bag, it exerts a force AND Since $P = F/A$, pressure is exerted.	[1]

Qn	Answer	Mark
2(b)(i)	$P_1V_1 = P_2V_2$ $80\,000 \times 500 = 100\,000 \times V_2$ $V_2 = 400\text{ cm}^3$	[1] [1]
2(b)(ii)	Any 2 from: <ul style="list-style-type: none"> no air molecules escape temperature remains constant air molecules obey ideal gas laws 	[2]
TOTAL		[6]
3(a)	$P_{\text{gas}} = P_0 + P_L$ $= 1.0 \times 10^5 + h\rho g$ $= 1.0 \times 10^5 + (0.57 \times 1.4 \times 10^4 \times 10)$ $= 179\,800$ $= 180\,000\text{ Pa (2sf)}$	[2] [1]
3(b)	When air is heated, molecules move faster AND hit the walls of the tube more frequently with larger force.	[1]
	(As the volume is constant,) pressure increases.	[1]
	(The higher pressure of trapped air pushes down the liquid,) causing x to increase.	[1]
TOTAL		[6]
4(a)	When an object is in equilibrium,	[1]
	the sum of clockwise moments about a point is equal to the sum of anticlockwise moment about the same point.	[1]
4(b)	The perpendicular distance of rubber band to pivot is smaller than that of the mass. Since moment = F x d , (to generate the same moment,) it has a larger force.	[1]
4(c)	$\text{ACW moment} = \text{CW moment} = F \times d$ $F \times 2.0 = 4.0 \times 18$ $F = 36\text{ N (2 sf)}$	[1] [1]
4(d)	If the weight of XY is included, the CW moment will increase. (Moment = F x d, since distance of rubber band to pivot remains unchanged,) the force of rubber band will be larger to generate the larger moment.	[1]
TOTAL		[6]
5(a)	The specific latent heat of a substance is the amount of energy needed to change the state of 1 kg of the substance	[1]
	without changing its temperature	[1]
5(b)(i)	$Q = ml_f$	

Qn	Answer	Mark
	$= 0.0050 \times 3.3 \times 10^5$ $= 1650$ $= 1700 \text{ J}$	[1] [1]
5(b)(ii)	Heat is conducted through the glass funnel to the ice.	[1]
TOTAL		[5]
6(a)	Real	[1]
6(b)	<p style="text-align: center;">thin converging lens</p>	[2]
6(c)	15.0 cm	[1]
TOTAL		[4]
7(a)	There is charging by friction AND Charges/ electrons transfer occurred between the person and the carpet when he walked across it.	[1]
	As the hand touched a (metal) door handle, discharging happened and hence he felt an electric shock OR Charge flow between the person and handle.	[1]
7(b)(i)	The drops repel each other	[1]
	as they are like charges/ have the same charge	[1]
7(b)(ii)	The drops are attracted by the leg as unlike charges attract .	[1]
TOTAL		[5]
8(a)	Any one: solar energy and hydroelectric generation	[1]
8(b)(i)	$E_k = \frac{1}{2} mv^2$ $= \frac{1}{2} \times 4.2 \times 10^7 \times 15^2$ $= 4.725 \times 10^9$ $= 4.7 \times 10^9 \text{ J (2 sf)}$	[1] [1]
8(b)(ii)	$E = Pt$ $= 8.4 \times 10^5 \times 30 \times 60$ $= 1.512 \times 10^9$	[1]

Qn	Answer	Mark
	$= 1.5 \times 10^9 \text{ J}$	[1]
8(b)(iii)	$\text{Efficiency} = E_{\text{out}} / E_{\text{in}} \times 100\%$ $= (1.512 \times 10^9) / (4.725 \times 10^9) \times 100\%$ $= 32 \%$	[1] [1]
TOTAL		[7]
9(a)	Adjust the variable resistor/ rheostat to change the effective resistance and current of the circuit.	[1]
9(b)(i)	(For a metallic conductor,) the current passing through it is directly proportional to the potential difference across it	[1]
	Provided that physical conditions OR temperature remains constant	[1]
9(b)(ii)	$R = V/I$ $R_1 = 7.6 / (320 \times 10^{-3}) = 24 \Omega$ $R_2 = 5.2 / (220 \times 10^{-3}) = 24 \Omega$ $R_3 = 2.4 / (100 \times 10^{-3}) = 24 \Omega$	[1]
9(b)(iii)	<p>For the first and second readings, $I > 200 \text{ mA}$, student should use the 0-10 A ammeter.</p> <p>For the third reading, student should use the 0-200 mA ammeter.</p>	[1]
TOTAL		[5]

Paper 2 Section B

Qn	Answer	Mark
10(a)(i)	Any two: <ul style="list-style-type: none"> • boiling is a fast process but evaporation is a slow process • boiling occurs throughout the liquid but evaporation occurs only at the surface • bubbles are formed during boiling but not evaporation • boiling occurs at boiling point but evaporation occurs at any temperature 	[2]
10(a)(ii)	Energy is used to break intermolecular bonds OR overcome intermolecular forces of liquid.	[1]
	Molecules move further apart OR increase in internal/ potential energy.	[1]
10(b)(i)	For $t = 1.0 \text{ min}$ $m = \rho V$ $= 1000 \times 4.6 \times 10^{-3} = 4.6 \text{ kg}$ For $t = 1.0 \text{ s}$ $m = 4.6 / 60$ $= 0.0766$ $= 0.076 \text{ kg}$	[1] [1]
10(b)(ii)	In one minute: $Q = mc\Delta\theta$ $= 0.0766 \times 4200 \times (37 - 16)$ $= 6760 \text{ J}$ In one second: $= 6760 / 60$ $= 113$ $= 110 \text{ J (2 sf)}$	[1] [1] [1]
10(b)(iii)	In the event of electrical fault , earthing protects the user from electrocution by allowing current to go to Earth safely	[1]
		TOTAL [10]
11(a)	$v = d/t = 1000 / (5.0 \times 10^{-6})$ $= 2.0 \times 10^8$ $n = c/v = (3.0 \times 10^8) / (2.0 \times 10^8)$ $= 1.5$	[1] [1]
11(b)	$n = \sin i / \sin r$ $\sin r = \sin 35^\circ / 1.5$ $r = 22.48$ $= 22.5^\circ$	[1] [1]

Qn	Answer	Mark
11(c)(i)	(The single pulse of light enters the optical fibre at angles of incidence like that of ray 1, 2 and 3.) They exit as 3 pulses of light at 10.0 μs , 10.3 μs and 10.8 μs respectively.	[1]
11(c)(ii)		[2]
11(c)(iii)	$1 / (0.9 \times 10^{-6})$ $= 1.1 \times 10^6$	[1] [1]
11(c)(iv)	<p>Over very long distances, the pulses of light exiting will have longer range of duration in the optical fibre. The subsequent pulses of light entering the fibre will take much longer time, to avoid overlapping of light.</p> <p>Data transmission will be much slower.</p>	[1]
TOTAL		[10]
12	EITHER	
12(a)(i)	$I = V / R_E$ $= 12 / (20 + 28)$ $= 0.25 \text{ A}$	[1] [1]
12(a)(ii)	a current carrying conductor will experience a force when it is placed in a magnetic field	[1]
12(a)(iii)	According to Fleming's Left Hand Rule,	[1]
	The magnetic field line is to the right, and current travelling from Z to Y (is into the page.)	[1]
	a downward force is exerted on YZ.	[1]
12(b)(i)	$R_E = (1/R_1 + 1/R_2)^{-1} + R_3$ $= (1/30 + 1/20)^{-1} + 28$ $= 12 + 28 = 40 \Omega$	[1] [1]
12(b)(ii)	Current in YZ is higher (as R_E decreases)	[1]
	(in the same magnetic field) the force exerted on YZ will increase.	[1]
TOTAL		[10]
12	OR	
12(a)	Coil A as it is the primary coil of a step-down transformer (and will have more turns than coil B)	[1]

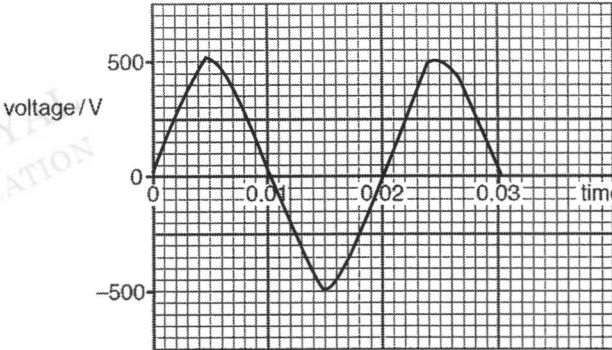
Qn	Answer	Mark
12(b)	Iron core links the magnetic field from the primary coil to the secondary coil.	[1]
12(c)	Coil B experience a changing magnetic field and emf is induced to oppose the change producing it.	[1]
12(d)	$N_B / N_A = V_B / V_A$ $N_B = (250 / 25000) \times 5000$ $= 50$	[1] [1]
12(e)(i)		[2]
12(e)(ii) 1	(since $P = IV$) Transmission at high voltage to keep current low.	[1]
	With low current, less heat is lost OR thickness of transmission cable can be reduced which will cost less.	[1]
12(e)(ii) 2	The high voltage will damage household appliances, hence it has to be lowered using a step-down transformer OR High voltage is dangerous to be used in the household.	[1]
TOTAL		[10]