

Name _____ ()	Class 4 _____
----------------	---------------



**CRESCENT GIRLS' SCHOOL
SECONDARY FOUR
PRELIMINARY EXAMINATION**

**ADDITIONAL MATHEMATICS
Paper 1**

4049/01

**24 August 2023
2 hours 15 minutes**

Candidates answer on the Question Paper.
No Additional Materials are required.

READ THESE INSTRUCTIONS FIRST

Write your name, class and index number in the spaces at the top of this page.
Write in dark blue or black pen.
You may use an HB pencil for any diagrams or graphs.
Do not use staples, paper clips, glue or correction fluid.

Answer **all** the questions.

Give non-exact numerical answers correct to three significant figures, or 1 decimal place in the case of angles in degrees, unless a different level of accuracy is specified in the question.
The use of an approved scientific calculator is expected, where appropriate.
You are reminded of the need for clear presentation in your answers.

At the end of the examination, fasten all your work securely together.
The number of marks is given in brackets [] at the end of each question or part question.
The total of the marks for this paper is **90**.

For Examiner's Use

Question	1	2	3	4	5	6	7	8	9	10	11	12	13	14
Marks														

Table of Penalties		Qn. No.	Parent's/ Guardian's Signature	90
Presentation	-1			
Accuracy/ Units	-1			

This question paper consists of 20 printed pages.

*Mathematical Formulae***1. ALGEBRA***Quadratic Equation*

For the equation $ax^2 + bx + c = 0$,

$$x = \frac{-b \pm \sqrt{b^2 - 4ac}}{2a}$$

Binomial expansion

$$(a+b)^n = a^n + \binom{n}{1}a^{n-1}b + \binom{n}{2}a^{n-2}b^2 + \dots + \binom{n}{r}a^{n-r}b^r + \dots + b^n,$$

where n is a positive integer and $\binom{n}{r} = \frac{n!}{r!(n-r)!} = \frac{n(n-r)\dots(n-r+1)}{r!}$

2. TRIGONOMETRY*Identities*

$$\sin^2 A + \cos^2 A = 1$$

$$\sec^2 A = 1 + \tan^2 A$$

$$\operatorname{cosec}^2 A = 1 + \cot^2 A$$

$$\sin(A \pm B) = \sin A \cos B \pm \cos A \sin B$$

$$\cos(A \pm B) = \cos A \cos B \mp \sin A \sin B$$

$$\tan(A \pm B) = \frac{\tan A \pm \tan B}{1 \mp \tan A \tan B}$$

$$\sin 2A = 2 \sin A \cos A$$

$$\cos 2A = \cos^2 A - \sin^2 A = 2 \cos^2 A - 1 = 1 - 2 \sin^2 A$$

$$\tan 2A = \frac{2 \tan A}{1 - \tan^2 A}$$

Formulae for ΔABC

$$\frac{a}{\sin A} = \frac{b}{\sin B} = \frac{c}{\sin C}$$

$$a^2 = b^2 + c^2 - 2bc \cos A$$

$$\Delta = \frac{1}{2}bc \sin A$$

3

- 1 Given that $k = 2\sqrt{2} - \sqrt{3}$, **without using the calculator**, express $3k - \frac{2}{k}$ in the form

$$\frac{a\sqrt{2} - b\sqrt{3}}{c}, \text{ where } a, b \text{ and } c \text{ are integers.}$$

[3]

-
- 2 The straight line $y = kx + 20$ intersects the curve $3y = 2kx^2 - 21$ at the points A and B whose x -coordinates are -3 and 4.5 respectively. Find the value of k .

[4]

4

3 Express $-3x^2 + 12x - 4$ in the form $a(x-h)^2 + k$, where a , h and k are integers.

Hence state the coordinates of the turning point of the curve $y = -3x^2 + 12x - 4$. [4]

DANYAL
EDUCATIONDANYAL
EDUCATION

4 Integrate $\tan^2 2x$ with respect to x .

[3]

DANYAL
EDUCATIONDANYAL
EDUCATIONDANYAL
EDUCATION

5

5 Express $\frac{6x^2 - 5x + 5}{(x-1)(x^2+2)}$ in partial fractions.

[4]

DANYAL
EDUCATIONDANYAL
EDUCATIONDANYAL
EDUCATIONDANYAL
EDUCATIONDANYAL
EDUCATION

6

6 $f(x) = x^{2n} - (p+1)x^2 + p$, where n and p are positive integers.

(a) Show that $(x+1)$ is a factor of $f(x)$ for all values of p . [2]

(b) Given $p = 4$,

(i) find the value of n for which $(x-2)$ is a factor, [2]

(ii) hence, solve $f(x) = 0$. [3]

7

7 For $0 \leq x \leq \pi$, $f(x) = 3 \sin nx$, where n is a positive integer, and $g(x) = 4 \cos 2x + 1$.

(i) Given that $\frac{\pi}{6}$ satisfies the equation $f(x) = g(x)$, show that smallest value for $n = 3$.

[2]

(ii) State the amplitude of $g(x)$.

[1]

(iii) Sketch, on the axes below, the graphs of $y = f(x)$ and $y = g(x)$.

[4]

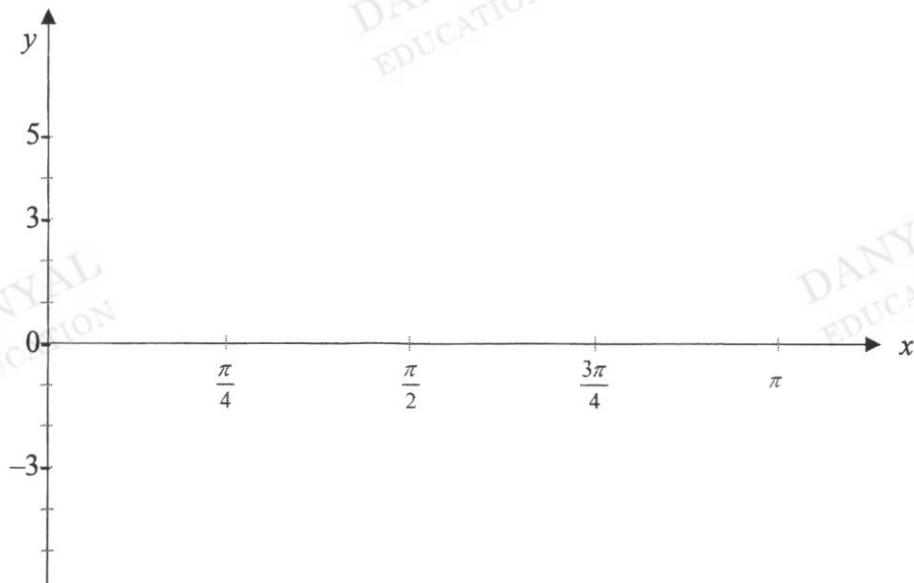

(iv) State, in terms of π , the other roots of the equation $f(x) = g(x)$ for $0 \leq x \leq \pi$.

[1]

8

- 8 A piece of wire, 100 cm in length, is bent to form the figure as shown.

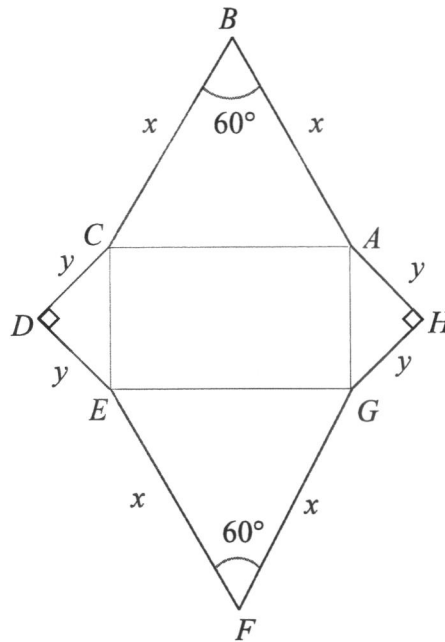

Given that angle $ABC = \text{angle } EFG = 60^\circ$, angle $CDE = \text{angle } GHA = 90^\circ$,

$AB = BC = EF = FG = x$ cm and $CD = DE = GH = HA = y$ cm.

- (a) Show that the area of the figure, P cm², is given by

$$P = \left(\frac{\sqrt{3}}{2} + 1 - \sqrt{2} \right) x^2 + (25\sqrt{2} - 50)x + 625.$$

[4]

(b) Find the value of x for which P has a stationary value.

[2]

DANYAL
EDUCATION

DANYAL
EDUCATION

DANYAL
EDUCATION

DANYAL
EDUCATION

DANYAL
EDUCATION

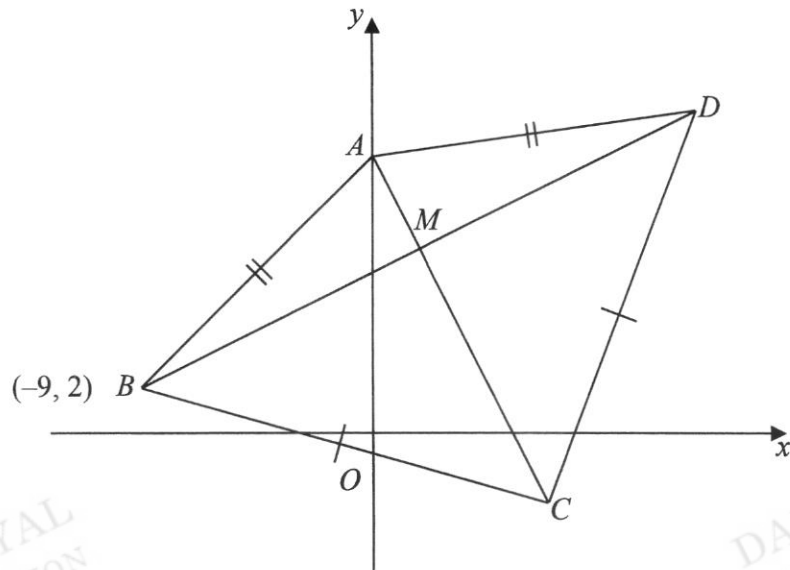

The diagram shows a kite $ABCD$ with $AB = AD$ and $CB = CD$.

The diagonals intersect at M . The point A lies on the y -axis, the point B is $(-9, 2)$ and the equation of AC is $2x + y = 9$.

(i) State the coordinates of A . [1]

(ii) Find the equation of BD . [2]

11

(iii) Find the coordinates of M and of D .

[4]

DANYAL
EDUCATIONDANYAL
EDUCATION

Given further that the area of the triangle ABD is $\frac{1}{4}$ of the area of the triangle CBD , find

(iv) the coordinates of C ,

[2]

DANYAL
EDUCATIONDANYAL
EDUCATION

(v) the area of the kite $ABCD$.

[2]

- 10 (a) Find in radians, the principal value of $\tan^{-1}\left(-\frac{1}{\sqrt{3}}\right)$. [2]

(b) Given $\sin 3\theta + \sin \theta = 2 \sin 2\theta \cos \theta$. Prove that

(i) $\cos 3\theta + \cos \theta = 2 \cos 2\theta \cos \theta$, [3]

(ii) $\frac{\sin \theta - \sin 2\theta + \sin 3\theta}{\cos \theta - \cos 2\theta + \cos 3\theta} = \tan 2\theta$. [3]

13

(c) Hence solve the equation $\frac{\cos \theta - \cos 2\theta + \cos 3\theta}{\sin \theta - \sin 2\theta + \sin 3\theta} = -\frac{1}{2}$ for $0 \leq \theta \leq \pi$. [3]

DANYAL
EDUCATIONDANYAL
EDUCATIONDANYAL
EDUCATIONDANYAL
EDUCATIONDANYAL
EDUCATION

- 11 In the diagram, not to scale, BC and CE are diameters of the circles, S_1 and S_2 , respectively. CE is tangent to S_1 at C , CF and BD meet at G , and G lies on the circumference of S_1 . F lies on the circumference of S_2 . CB produced and EF produced meet at A .

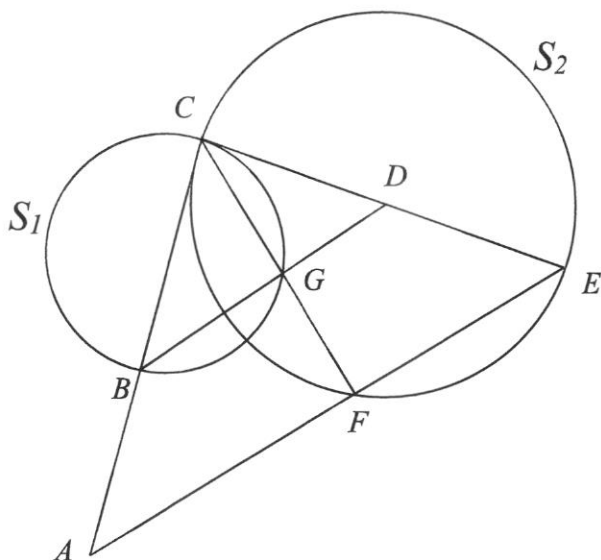

Show that

- (i) triangles CBG and DCG are similar,

[3]

15

(ii) lines BGD and AFE are parallel, [2]

(iii) $CE^2 = AE \times EF$. [4]

DANYAL
EDUCATION

DANYAL
EDUCATION

DANYAL
EDUCATION

DANYAL
EDUCATION

DANYAL
EDUCATION

12 Solve the following equations:

(a) $\log_3(2x-1) - \log_{\sqrt{3}} 3 = \log_2 4$

[4]

DANYAL
EDUCATION

DANYAL
EDUCATION

DANYAL
EDUCATION

DANYAL
EDUCATION

DANYAL
EDUCATION

17

(b) $\frac{1}{\sqrt{25^{2x+1}}} + \frac{10}{5^{x+2}} = 3.$

[4]

DANYAL
EDUCATIONDANYAL
EDUCATIONDANYAL
EDUCATIONDANYAL
EDUCATIONDANYAL
EDUCATION

- 13 The sketch shows the graphs of the curve, $y = \frac{1}{x-1} - 3$, the lines $3y = 4x - 9$ and $y = 3$. The curve and the line $3y = 4x - 9$ intersect at P . The curve cuts the x -axis at $R\left(\frac{4}{3}, 0\right)$. The line $3y = 4x - 9$ cuts the x -axis at $Q\left(2\frac{1}{4}, 0\right)$.

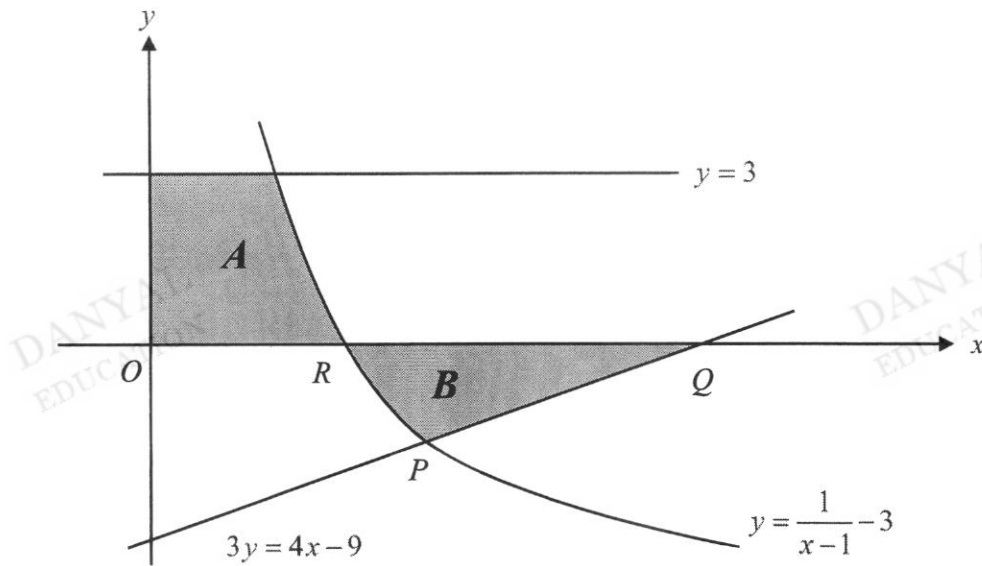

The region A is bounded by the curve, $y = \frac{1}{x-1} - 3$, the line $y = 3$ and the y -axis.

The region B is bounded by the curve, the line $3y = 4x - 9$, and the x -axis.

- (i) Verify that the coordinates of P are $\left(\frac{3}{2}, -1\right)$. [2]

(ii) Find the area of A and of B .

[6]

DANYAL
EDUCATION

DANYAL
EDUCATION

DANYAL
EDUCATION

DANYAL
EDUCATION

DANYAL
EDUCATION

20

- 14 A vessel is in the shape of a right circular cone. The radius of cone is 8 cm and the height is 32 cm. Water is poured into the vessel at a rate of $10 \text{ cm}^3/\text{s}$.

Calculate the rate at which the water level is rising when the vessel is $\frac{1}{8}$ full. [4]

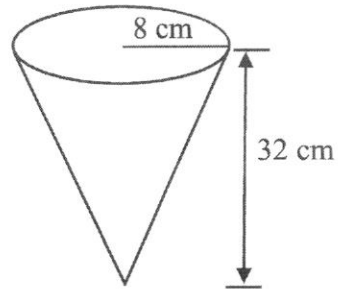

END OF PAPER

Name:	Register No.:	Class:
-------	---------------	--------



**CRESCENT GIRLS' SCHOOL
SECONDARY FOUR 2023
PRELIMINARY EXAMINATION**

ADDITIONAL MATHEMATICS

4049/02

Paper 2

25 August 2023

Candidates answer on the Question Paper.

2 hours 15 mins

No Additional Materials are required.

READ THESE INSTRUCTIONS FIRST

Write your name and index number on all the work you hand in.

Write in dark blue or black pen on both sides of the paper.

You may use an HB pencil for any diagrams or graphs.

Do not use staples, paper clips, glue or correction fluid.

Answer **all** questions.

If working is needed for any question it must be shown with the answer.

Omission of essential working will result in loss of marks.

The use of an approved scientific calculator is expected, where appropriate.

If the degree of accuracy is not specified in the question, and if the answer is not exact, give the answer to three significant figures. Give answers in degrees to one decimal place.

For π , use either your calculator value or 3.142, unless the question requires the answer in terms of π .

At the end of the examination, fasten all your work securely together.

The number of marks is given in brackets [] at the end of each question or part question.

The total of the marks for this paper is **90**.

For Examiner's Use

Question	1	2	3	4	5	6	7	8	9	10	11
Marks											

Table of Penalties		Qn. No.	90
Presentation	-1		
Significant Figures/ Units	-1	Parent's/Guardian's Signature	

This document consists of **20** printed pages.

Mathematical Formulae**1. ALGEBRA***Quadratic Equation*

For the equation $ax^2 + bx + c = 0$,

$$x = \frac{-b \pm \sqrt{b^2 - 4ac}}{2a}$$

Binomial expansion

$$(a+b)^n = a^n + \binom{n}{1}a^{n-1}b + \binom{n}{2}a^{n-2}b^2 + \dots + \binom{n}{r}a^{n-r}b^r + \dots + b^n,$$

where n is a positive integer and $\binom{n}{r} = \frac{n!}{r!(n-r)!} = \frac{n(n-1)\dots(n-r+1)}{r!}$

2. TRIGONOMETRY*Identities*

$$\sin^2 A + \cos^2 A = 1$$

$$\sec^2 A = 1 + \tan^2 A$$

$$\operatorname{cosec}^2 A = 1 + \cot^2 A$$

$$\sin(A \pm B) = \sin A \cos B \pm \cos A \sin B$$

$$\cos(A \pm B) = \cos A \cos B \mp \sin A \sin B$$

$$\tan(A \pm B) = \frac{\tan A \pm \tan B}{1 \mp \tan A \tan B}$$

$$\sin 2A = 2 \sin A \cos A$$

$$\cos 2A = \cos^2 A - \sin^2 A = 2 \cos^2 A - 1 = 1 - 2 \sin^2 A$$

$$\tan 2A = \frac{2 \tan A}{1 - \tan^2 A}$$

Formulae for $\triangle ABC$

$$\frac{a}{\sin A} = \frac{b}{\sin B} = \frac{c}{\sin C}$$

$$a^2 = b^2 + c^2 - 2bc \cos A$$

$$\Delta = \frac{1}{2} ab \sin C$$

1 (i) The equation of a curve is $f(x) = \frac{\sqrt{x^2+1}}{3x+4}$, $x \neq p$.

Find $f'(x)$, simplifying your answer as a single fraction. Hence determine the gradient of the tangent at the point on the curve where $x = 0$. [5]

DANYAL
EDUCATION

DANYAL
EDUCATION

DANYAL
EDUCATION

DANYAL
EDUCATION

DANYAL
EDUCATION

(ii) State the value of p .

[1]

4

- 2 By using a suitable substitution, show that $3e^{\sqrt{4x}} - 4 = e^{\sqrt{x}}$ has only one solution and find its value correct to 2 significant figures. [5]

DANYAL
EDUCATIONDANYAL
EDUCATIONDANYAL
EDUCATIONDANYAL
EDUCATIONDANYAL
EDUCATION

5

- 3 The diagram below shows a circle $x^2 + y^2 = 9$ and a straight line $y = kx + 5$. Find the range of values of k .

[5]

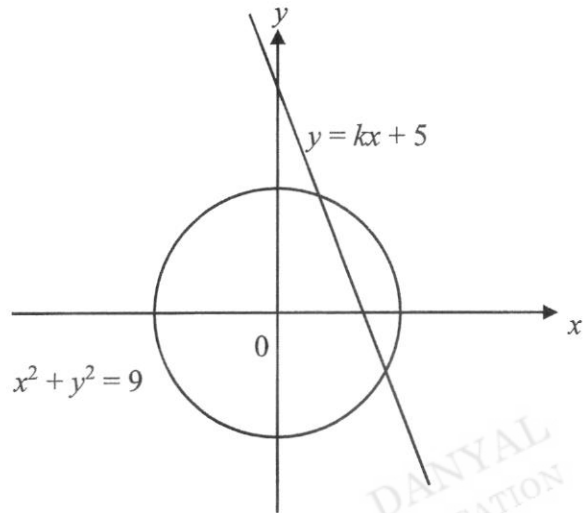

4 (a) Show that $\frac{d}{dx} \ln(\sin x + \cos x) = \tan\left(\frac{\pi}{4} - x\right)$. [4]

(b) Solve $\tan\left(\frac{\pi}{4} - x\right) = -3$ for $0 \leq x \leq \pi$. [2]

5 (i) Differentiate $3x \cos \frac{1}{2}x$ with respect to x . [3]

(ii) Hence, find the exact value of $\int_0^{\frac{\pi}{3}} x \sin \frac{1}{2}x \, dx$. [4]

- 6 The figure (not drawn to scale) shows a right-angled triangle ABC constructed between two parallel lines.

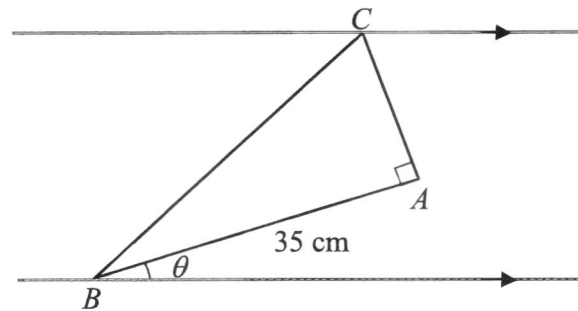

The area of triangle ABC is 210 cm^2 . $AB = 35 \text{ cm}$ and makes an acute angle θ with one of the lines.

- (i) Show that the distance between the parallel lines, $d = (12 \cos \theta + 35 \sin \theta) \text{ cm}$. [2]

- (ii) Express d in the form $R \cos(\theta - \alpha)$, where R is a constant and α is an angle in radians.

[3]

DANYAL
EDUCATIONDANYAL
EDUCATION

- (iii) Find the value of θ when $d = 28$ cm.

[2]

DANYAL
EDUCATIONDANYAL
EDUCATIONDANYAL
EDUCATION

7 The coefficient of $\frac{1}{x^3}$ is 512 in the expansion of $\left(\frac{2}{x} + px^2\right)^9$, where $p < 0$.

(i) By first working out the general term of $\left(\frac{2}{x} + px^2\right)^9$, find the value of p . [3]

(ii) Using the results in (i),

(a) show that the coefficient of the first term in the expansion of $\left(\frac{2}{x} + px^2\right)^9$ is also 512. [1]

- (b) find the $\frac{1}{x^6}$ term in the expansion of $\left(\frac{2}{x} + px^2\right)^9$. [2]

- (c) explain why the term in $\frac{1}{x^4}$ does not exist in the expansion of

$$\left(\frac{2}{x} + px^2\right)^9 \left(\frac{1}{8x} + \frac{1}{12}x^2\right). \quad [2]$$

- 8 The diagram below shows the curve $y = \ln(x+3)^4$ which cuts the y -axis at $(0, 4 \ln b)$. The line l_1 , cuts the y -axis at $(0, -2)$ and meets the curve at $(-1, 4 \ln a)$.

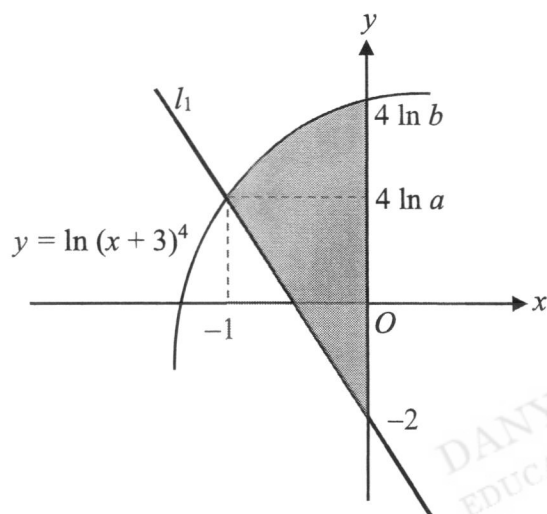

- (i) Find the value of a and of b .

[2]

- (ii) Find the equation of l_1 giving your answer in the form $y = (p \ln q + r)x + s$ where p, q, r and s are integers. [2]

- (iii) Calculate the area of the shaded region, giving your answer to 3 decimal places. [6]

- 9 Two particles, P and Q , each moving in a straight line passes a point, Z , at the same instant. The displacement of P , s_p m is given by $s_p = \frac{t^3}{3} - \frac{3t^2}{2} + 5t$ where t is the time in seconds after passing Z .

The particle Q passes Z with a velocity of 11 m/s and its acceleration, a_Q m/s² is given by $a_Q = 2t - 6$ where t is the time in seconds after passing Z .

- (a) Find the value of t for which the velocities of P and Q are equal. [4]

- (b) Explain why particle Q will always move in the same direction after passing Z . [2]

- (c) Determine, with explanation, if there is any instance when particle Q is ahead of particle P .

[4]

DANYAL
EDUCATIONDANYAL
EDUCATIONDANYAL
EDUCATIONDANYAL
EDUCATIONDANYAL
EDUCATION

- (d) Find the average velocity of particle Q in the first 5 seconds.

[2]

- 10 The diagram shows two circles C_1 and C_2 .

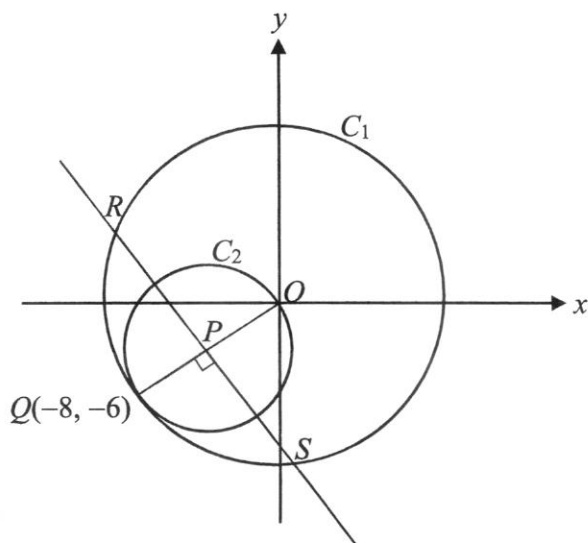

C_1 has its centre at the origin O while C_2 passes through O and has its centre at P . The point $Q(-8, -6)$ lies on both circles and OQ is the diameter of C_2 .

- (i) Find the equations of C_1 and C_2 .

[5]

The line through P perpendicular to OQ meets the circle C_1 at the points R and S .

- (ii) Show that the x -coordinates of R and S are $a - b\sqrt{3}$ and $a + b\sqrt{3}$ respectively, where a and b are integers to be determined. [7]

DANYAL
EDUCATION

DANYAL
EDUCATION

DANYAL
EDUCATION

DANYAL
EDUCATION

DANYAL
EDUCATION

- 11 (a)** The population P , in millions of a city, recorded in the month of January for various years is modelled by the equation $P = 10 + at^n$, where t is the time measured in years from January 2002 and a and n are constants.

The values are tabulated below.

Year	2005	2012	2017	2022
P	20.4	73.2	126.2	188.9

- (i) On the grid opposite, plot $\lg(P-10)$ against $\lg t$ for the given data and draw a straight-line graph to estimate the values of a and n , giving your answers to one decimal place. [6]

- (ii) Use your graph to determine the year in which the population reached 100 millions. [2]

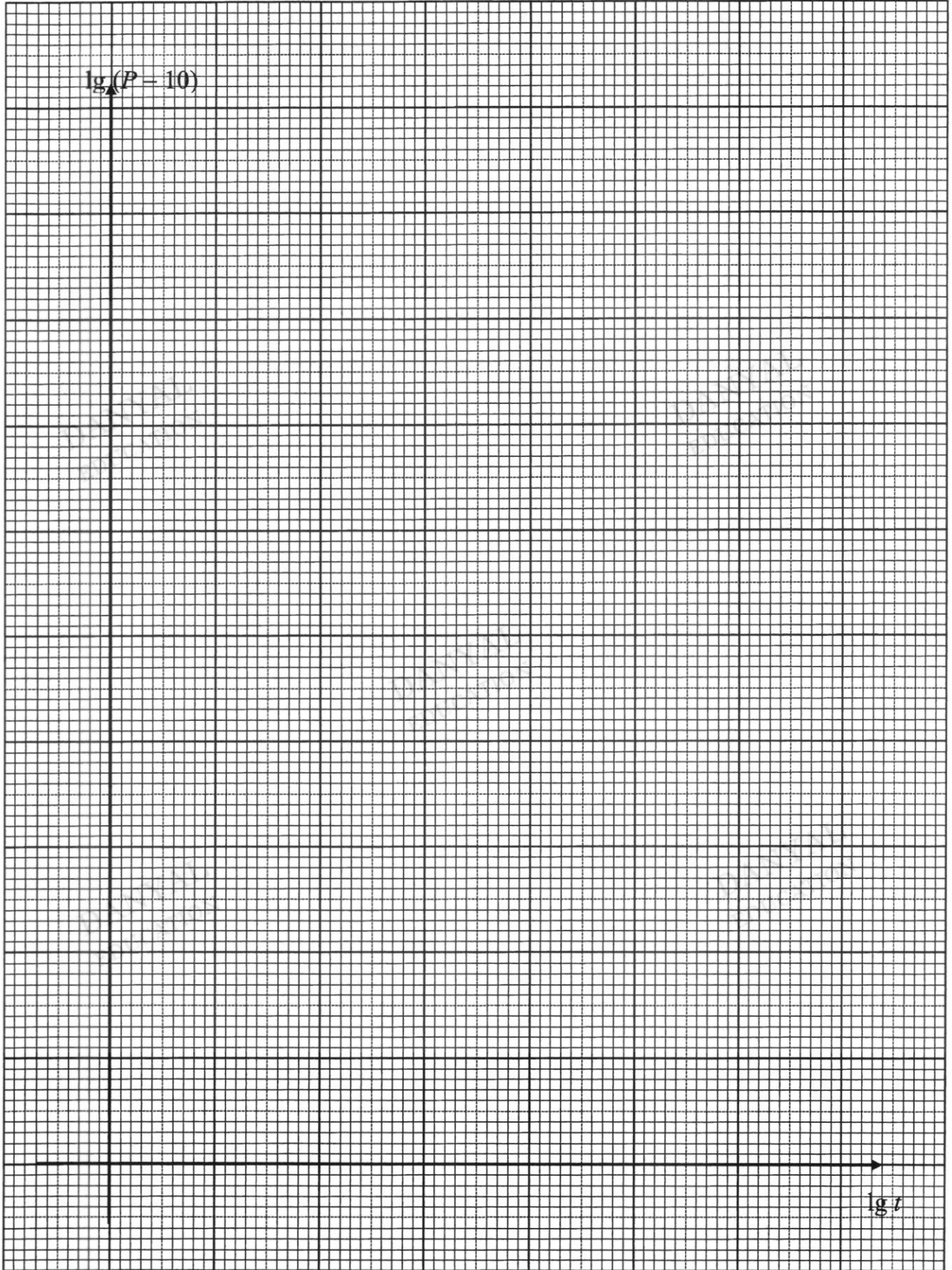

- (b) The diagram shows part of a straight-line graph, passing through the points $(2, h)$ and $(5, 4)$, and representing the equations $2x^3 + kx = 3y$, where k and h are constants.
Find the value of h and of k .

[4]

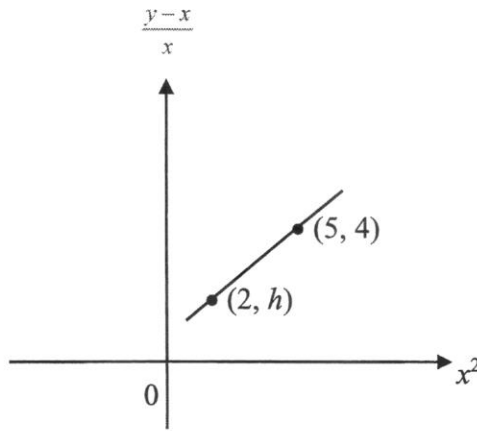

End of Paper

Name _____ Solutions _____ ()	Class 4 _____
--------------------------------	---------------



**CRESCENT GIRLS' SCHOOL
SECONDARY FOUR
PRELIMINARY EXAMINATION**

**ADDITIONAL MATHEMATICS
Paper 1**

4049/01

**24 August 2023
2 hours 15 minutes**

Candidates answer on the Question Paper.
No Additional Materials are required.

READ THESE INSTRUCTIONS FIRST

Write your name, class and index number in the spaces at the top of this page.
Write in dark blue or black pen.
You may use an HB pencil for any diagrams or graphs.
Do not use staples, paper clips, glue or correction fluid.

Answer **all** the questions.

Give non-exact numerical answers correct to three significant figures, or 1 decimal place in the case of angles in degrees, unless a different level of accuracy is specified in the question.
The use of an approved scientific calculator is expected, where appropriate.
You are reminded of the need for clear presentation in your answers.

At the end of the examination, fasten all your work securely together.
The number of marks is given in brackets [] at the end of each question or part question.
The total of the marks for this paper is **90**.

For Examiner's Use

Question	1	2	3	4	5	6	7	8	9	10	11	12	13	14
Marks	3	4	4	3	4	7	8	6	11	11	9	8	8	4

Table of Penalties		Qn. No.	90
Presentation	-1		
Accuracy/ Units	-1	Parent's/ Guardian's Signature	

This question paper consists of 20 printed pages.

*Mathematical Formulae***1. ALGEBRA***Quadratic Equation*

For the equation $ax^2 + bx + c = 0$,

$$x = \frac{-b \pm \sqrt{b^2 - 4ac}}{2a}$$

Binomial expansion

$$(a+b)^n = a^n + \binom{n}{1}a^{n-1}b + \binom{n}{2}a^{n-2}b^2 + \dots + \binom{n}{r}a^{n-r}b^r + \dots + b^n,$$

where n is a positive integer and $\binom{n}{r} = \frac{n!}{r!(n-r)!} = \frac{n(n-1)\dots(n-r+1)}{r!}$

2. TRIGONOMETRY*Identities*

$$\sin^2 A + \cos^2 A = 1$$

$$\sec^2 A = 1 + \tan^2 A$$

$$\operatorname{cosec}^2 A = 1 + \cot^2 A$$

$$\sin(A \pm B) = \sin A \cos B \pm \cos A \sin B$$

$$\cos(A \pm B) = \cos A \cos B \mp \sin A \sin B$$

$$\tan(A \pm B) = \frac{\tan A \pm \tan B}{1 \mp \tan A \tan B}$$

$$\sin 2A = 2 \sin A \cos A$$

$$\cos 2A = \cos^2 A - \sin^2 A = 2 \cos^2 A - 1 = 1 - 2 \sin^2 A$$

$$\tan 2A = \frac{2 \tan A}{1 - \tan^2 A}$$

Formulae for ΔABC

$$\frac{a}{\sin A} = \frac{b}{\sin B} = \frac{c}{\sin C}$$

$$a^2 = b^2 + c^2 - 2bc \cos A$$

$$\Delta = \frac{1}{2}bc \sin A$$

- 1 Given that $k = 2\sqrt{2} - \sqrt{3}$, **without using the calculator**, express $3k - \frac{2}{k}$ in the form

$$\frac{a\sqrt{2} - b\sqrt{3}}{c}, \text{ where } a, b \text{ and } c \text{ are integers.} \quad [3]$$

$ \begin{aligned} k &= 2\sqrt{2} - \sqrt{3} \\ 3k - \frac{2}{k} &= 3(2\sqrt{2} - \sqrt{3}) - \frac{2}{2\sqrt{2} - \sqrt{3}} \\ &= 6\sqrt{2} - 3\sqrt{3} - \frac{2(2\sqrt{2} + \sqrt{3})}{8 - 3} \\ &= 6\sqrt{2} - 3\sqrt{3} - \frac{4}{5}\sqrt{2} - \frac{2}{5}\sqrt{3} \\ &= \frac{26\sqrt{2} - 17\sqrt{3}}{5} \\ &= \frac{26}{5}\sqrt{2} - \frac{17}{5}\sqrt{3} \end{aligned} $	
--	--

- 2 The straight line $y = kx + 20$ intersects the curve $3y = 2kx^2 - 21$ at the points A and B whose x -coordinates are -3 and 4.5 respectively. Find the value of k . [4]

$ \begin{aligned} 3(kx + 20) &= 2kx^2 - 21 \\ 2kx^2 - 3kx - 81 &= 0 \\ 2kx^2 - 3kx - 81 &= x^2 - 1.5x - \frac{81}{2k} = 0 \\ -3 \text{ and } 4.5 &\text{ are solutions} \\ (x + 3)(x - 4.5) &= 0 \\ x^2 - 1.5x - 13.5 &= 0 \\ \text{by comparison} \\ -\frac{81}{2k} &= -13.5 \\ k &= 3 \end{aligned} $	
---	--

4

- 3 Express $-3x^2 + 12x - 4$ in the form $a(x-h)^2 + k$, where a , h and k are integers.

Hence state the coordinates of the turning point of the curve $y = -3x^2 + 12x - 4$. [4]

$-3x^2 + 12x - 4 = -3(x^2 - 4x) - 4$ $-3(x^2 - 4x + 2^2 - 2^2) - 4 = -3(x-2)^2 + 8$ <p>Turning point (2, 8)</p>	
---	--

- 4 Integrate $\tan^2 2x$ with respect to x . [3]

$\int \tan^2 2x \, dx = \int \sec^2 2x - 1 \, dx$ $= \frac{\tan 2x}{2} - x + c \text{ (} c \text{ is a constant)}$	
--	--

- 5 Express $\frac{6x^2 - 5x + 5}{(x-1)(x^2+2)}$ in partial fractions.

[4]

$\frac{6x^2 - 5x + 5}{(x-1)(x^2+2)} = \frac{A}{x-1} + \frac{Bx+C}{x^2+2}$ $6x^2 - 5x + 5 = A(x^2+2) + (Bx+C)(x-1)$ <p>Sub $x=1$,</p> $6 = 3A$ $A = 2$ <p>Sub $x=0$,</p> $5 = 2A - C$ $C = -1$ <p>Sub $x=2$,</p> $2B = 8$ $B = 4$ $\therefore \frac{6x^2 - 5x + 5}{(x-1)(x^2+2)} = \frac{2}{x-1} + \frac{4x-1}{x^2+2}$	
--	--

DANYAL
EDUCATIONDANYAL
EDUCATIONDANYAL
EDUCATION

6

6 $f(x) = x^{2n} - (p+1)x^2 + p$, where n and p are positive integers.

(a) Show that $(x+1)$ is a factor of $f(x)$ for all values of p . [2]

$f(-1) = (-1)^{2n} - (p+1)(-1)^2 + p$ $= 1 - (p+1)(1) + p$ $= 0$ <p>Therefore $(x+1)$ is a factor</p>	
--	--

(b) Given $p = 4$,

(i) find the value of n for which $(x-2)$ is a factor, [2]

$f(2) = 0$ $0 = 2^{2n} - (4+1)(2)^2 + 4$ $0 = 2^{2n} - 16$ $n = 2$	
--	--

(ii) hence, solve $f(x) = 0$. [3]

$x^4 - 5x^2 + 4 = (x+1)(x-2)(x^2 + ax + b)$ <p>by observation</p> $b = -2$ <p>substitute $x = 1$,</p> $1 - 5 + 4 = 2(-1)(1 + a - 2)$ $a = 1$ $(x+1)(x-2)(x^2 + x - 2) = 0$ $(x+1)(x-2)(x-1)(x+2) = 0$ $x = -1, 1, -2, 2$	
---	--

7 For $0 \leq x \leq \pi$, $f(x) = 3 \sin nx$, where n is a positive integer, and $g(x) = 4 \cos 2x + 1$.

(i) Given that $\frac{\pi}{6}$ satisfies the equation $f(x) = g(x)$, show that smallest value for $n = 3$. [2]

$3 \sin n\left(\frac{\pi}{6}\right) = 4 \cos 2\left(\frac{\pi}{6}\right) + 1$ $\sin n\left(\frac{\pi}{6}\right) = 1$ smallest $n = 3$	
---	--

(ii) State the amplitude of $g(x)$. [1]

Amplitude = 4	
---------------	--

(iii) Sketch, on the axes below, the graphs of $y = f(x)$ and $y = g(x)$. [4]

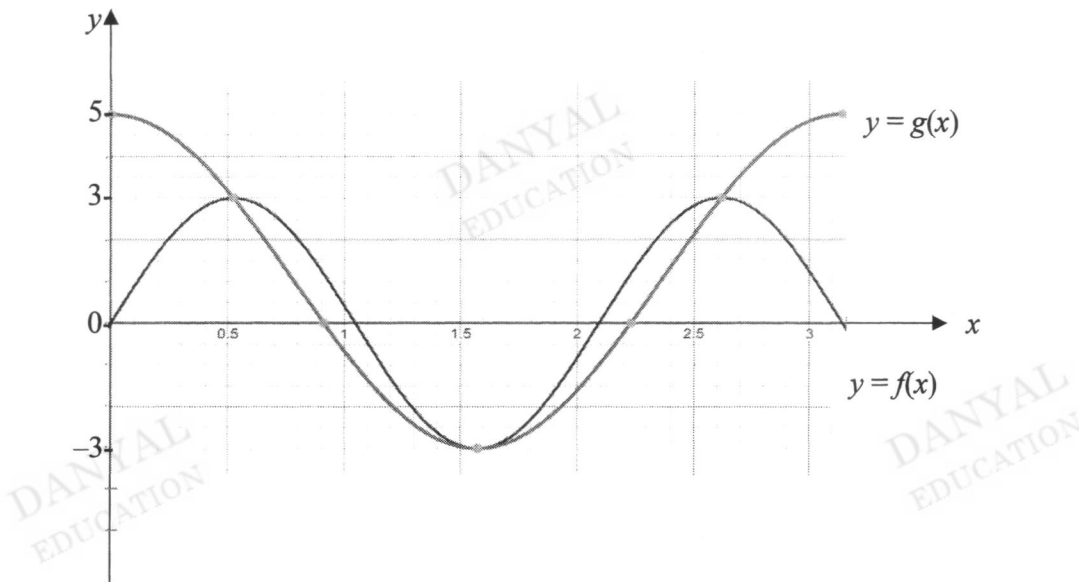

$f(x)$ $g(x)$	
------------------	--

(iv) State, in terms of π , the other roots of the equation $f(x) = g(x)$ for $0 \leq x \leq \pi$. [1]

$\frac{\pi}{2}, \frac{5\pi}{6}$	
---------------------------------	--

8

- 8 A piece of wire, 100 cm in length, is bent to form the figure as shown.

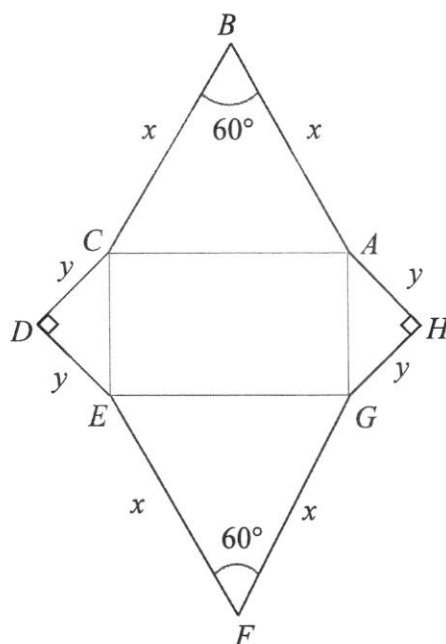

Given that angle $ABC = \text{angle } EFG = 60^\circ$, angle $CDE = \text{angle } GHA = 90^\circ$,

$AB = BC = EF = FG = x$ cm and $CD = DE = GH = HA = y$ cm.

- (a) Show that the area of the figure, P cm², is given by

$$P = \left(\frac{\sqrt{3}}{2} + 1 - \sqrt{2} \right) x^2 + (25\sqrt{2} - 50)x + 625. \quad [4]$$

$$4(x + y) = 100 \Rightarrow$$

$$x + y = 25$$

$$y = 25 - x$$

$$CE = \sqrt{y^2 + y^2} = \sqrt{2}y$$

$$P = 2 \times \text{Area of } \triangle ABC + \\ 2 \times \text{Area of } \triangle CDE + \\ \text{Area of rectangle } ACEG$$

$$= x^2 \sin 60^\circ + y^2 + x(\sqrt{2}y)$$

$$= \frac{\sqrt{3}}{2} x^2 + (25 - x)^2 + \sqrt{2}x(25 - x)$$

$$= \frac{\sqrt{3}}{2} x^2 + 625 - 50x + x^2 + 25\sqrt{2}x - \sqrt{2}x^2$$

$$= \left(\frac{\sqrt{3}}{2} + 1 - \sqrt{2} \right) x^2 + (25\sqrt{2} - 50)x + 625$$

(b) Find the value of x for which P has a stationary value.

[2]

$$\frac{dP}{dx} = 2\left(\frac{\sqrt{3}}{2} + 1 - \sqrt{2}\right)x + 25\sqrt{2} - 50$$

$$\frac{dP}{dx} = 0$$

$$2\left(\frac{\sqrt{3}}{2} + 1 - \sqrt{2}\right)x = 50 - 25\sqrt{2}$$

$$x = \frac{50 - 25\sqrt{2}}{2\left(\frac{\sqrt{3}}{2} + 1 - \sqrt{2}\right)} = 16.2 \text{ (3 s.f.)}$$

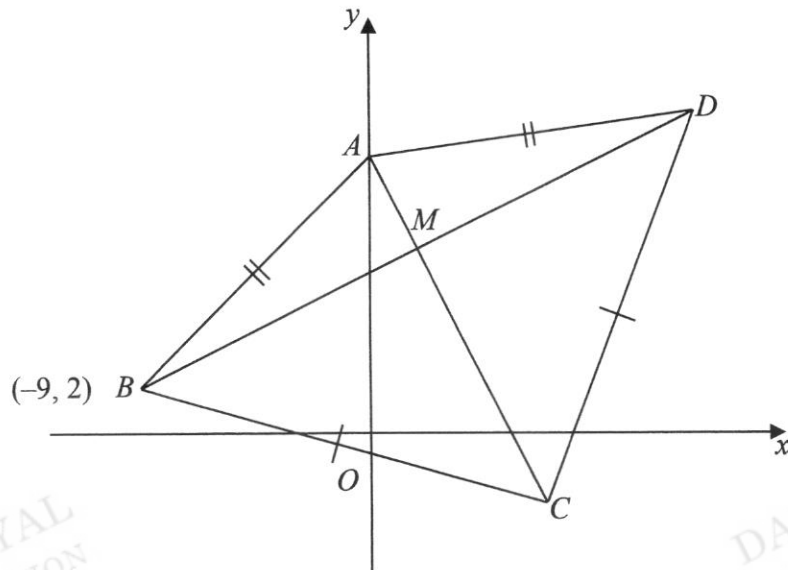

The diagram shows a kite $ABCD$ with $AB = AD$ and $CB = CD$.

The diagonals intersect at M . The point A lies on the y -axis, the point B is $(-9, 2)$ and the equation of AC is $2x + y = 9$.

- (i) State the coordinates of A . [1]

$A(0, 9)$	
-----------	--

- (ii) Find the equation of BD . [2]

<p>Gradient of $AC = -2$ Gradient of $BD = \frac{1}{2}$ Equation BD : $y - 2 = \frac{1}{2}(x - (-9))$ $y = \frac{1}{2}x + 6\frac{1}{2}$</p>	
--	--

11

(iii) Find the coordinates of M and of D .

[4]

<p>By solving simultaneous equations</p> $y = \frac{1}{2}x + 6\frac{1}{2} \text{ and } 2x + y = 9$ $9 - 2x = \frac{1}{2}x + 6\frac{1}{2}$ $x = 1$ $y = 7$ $M(1, 7)$ <p>M is mid-point of BD</p> $\frac{-9 + x_D}{2} = 1, \frac{2 + y_D}{2} = 7$ $D(11, 12)$	
---	--

Given further that the area of the triangle ABD is $\frac{1}{4}$ of the area of the triangle CBD , find

(iv) the coordinates of C ,

[2]

$MC = 4AM$ $x_C = 1 + 4(1) = 5, y_C = 7 - 4(2) = -1$ $C(5, -1)$	
---	--

(v) the area of the kite $ABCD$.

[2]

$\frac{1}{2} \begin{vmatrix} 0 & -9 & 5 & 11 & 0 \\ 9 & 2 & -1 & 12 & 9 \end{vmatrix}$ $= 125 \text{ units}^2$	
--	--

- 10 (a) Find in radians, the principal value of $\tan^{-1}\left(-\frac{1}{\sqrt{3}}\right)$. [2]

<p>Principal value of $\tan^{-1}\left(-\frac{1}{\sqrt{3}}\right)$ is in the 4th quadrant</p> <p>Since $\tan\left(\frac{\pi}{3}\right) = \frac{1}{\sqrt{3}}$,</p> <p>The principal value is $-\frac{\pi}{6}$ or -0.524.</p>	
---	--

- (b) Given $\sin 3\theta + \sin \theta = 2 \sin 2\theta \cos \theta$. Prove that

(i) $\cos 3\theta + \cos \theta = 2 \cos 2\theta \cos \theta$, [3]

$\begin{aligned} \cos 3\theta + \cos \theta &= \cos 2\theta \cos \theta - \sin 2\theta \sin \theta + \cos \theta \\ &= (1 - 2\sin^2 \theta) \cos \theta - 2\sin^2 \theta \cos \theta + \cos \theta \\ &= 2\cos \theta - 4\sin^2 \theta \cos \theta \\ &= 2\cos \theta(1 - 2\sin^2 \theta) \\ &= 2\cos 2\theta \cos \theta \end{aligned}$	
--	--

(ii) $\frac{\sin \theta - \sin 2\theta + \sin 3\theta}{\cos \theta - \cos 2\theta + \cos 3\theta} = \tan 2\theta$.

[3]

$\begin{aligned} \frac{\sin \theta - \sin 2\theta + \sin 3\theta}{\cos \theta - \cos 2\theta + \cos 3\theta} &= \frac{\sin 3\theta + \sin \theta - \sin 2\theta}{\cos 3\theta + \cos \theta - \cos 2\theta} \\ &= \frac{2\sin 2\theta \cos \theta - \sin 2\theta}{2\cos 2\theta \cos \theta - \cos 2\theta} \\ &= \frac{\sin 2\theta(2\cos \theta - 1)}{\cos 2\theta(2\cos \theta - 1)} \\ &= \tan 2\theta \end{aligned}$	
---	--

13

- (c) Hence solve the equation $\frac{\cos \theta - \cos 2\theta + \cos 3\theta}{\sin \theta - \sin 2\theta + \sin 3\theta} = -\frac{1}{2}$ for $0 \leq \theta \leq \pi$. [3]

$\frac{\sin \theta - \sin 2\theta + \sin 3\theta}{\cos \theta - \cos 2\theta + \cos 3\theta} = -2$ $\tan 2\theta = -2$ $\alpha = 1.1071$ $2\theta = 2.0345\dots, 5.1761\dots$ $\theta = 1.02, 2.59 \text{ (3 s.f.)}$	
--	--

DANYAL
EDUCATIONDANYAL
EDUCATIONDANYAL
EDUCATIONDANYAL
EDUCATIONDANYAL
EDUCATION

- 11 In the diagram, not to scale, BC and CE are diameters of the circles, S_1 and S_2 , respectively. CE is tangent to S_1 at C , CF and BD meet at G , and G lies on the circumference of S_1 . F lies on the circumference of S_2 . CB produced and EF produced meet at A .

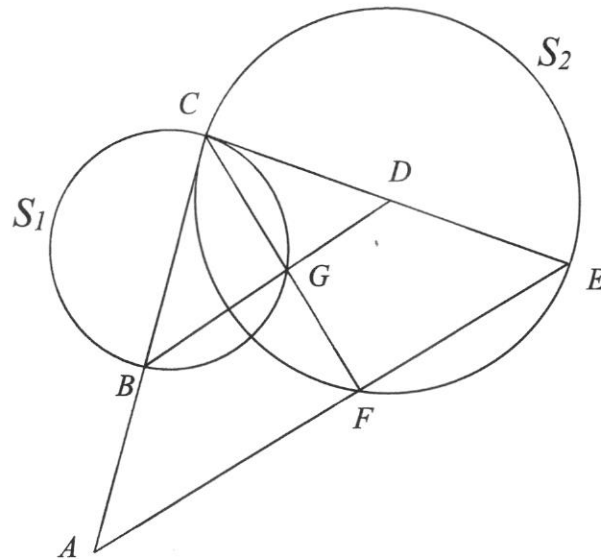

Show that

- (i) triangles CBG and DCG are similar,

[3]

$$\angle CGB = 90^\circ \text{ (Angle in a semi-circle)}$$

$$\angle CGD = 90^\circ \text{ (adjacent angles on a straight line)}$$

$$\therefore \angle CGB = \angle CGD$$

$$\angle CBG = \angle DCG$$

(Alternate Segment Theorem/ Tangent-Chord Theorem)

Therefore, by AA pty, triangles CBG and DCG are similar

15

(ii) lines BGD and AFE are parallel,

[2]

$\angle CFE = 90^\circ$ (Angle in a semi-circle) Since $\angle CGD = 90^\circ$ as well, lines BGD and AFE are parallel by means of corresponding angles	
--	--

(iii) $CE^2 = AE \times EF$.

[4]

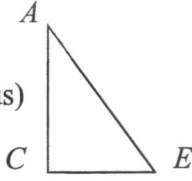
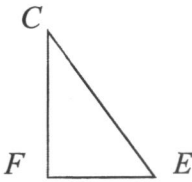
<p>In triangles CEF and AEC,</p> <p>$\angle EFC = 90^\circ$ (Angle in a semicircle)</p> <p>$\angle ECA = 90^\circ$ (Tangent perpendicular to radius)</p> <p>Therefore $\angle EFC = \angle ECA$.</p> <p>$\angle CEF = \angle AEC$ (Common angle)</p> <p>Triangles CEF and AEC are similar (AA).</p> <p>Comparing triangles AEC and CEF,</p> $\frac{CE}{AE} = \frac{FE}{CE}$ $CE \times CE = FE \times AE$ $CE^2 = AE \times EF$	 
---	---

12 Solve the following equations:

(a) $\log_3(2x-1) - \log_{\sqrt{3}} 3 = \log_2 4$

[4]

$\log_3(2x-1) - \log_{\sqrt{3}} 3 = \log_2 4$ $\log_3(2x-1) - \frac{\log_3 3}{\log_3 \sqrt{3}} = \log_2 4$ $\log_3(2x-1) - \frac{1}{\log_3 3^{\frac{1}{2}}} = \log_2 2^2$ $\log_3(2x-1) - \frac{1}{\frac{1}{2} \log_3 3} = 2 \log_2 2$ $\log_3(2x-1) - 2 = 2$ $\log_3(2x-1) = 4$ $2x-1 = 3^4$ $x = \frac{3^4+1}{2} = 41$	<p>DANYAL EDUCATION</p>
--	-----------------------------

DANYAL
EDUCATION

DANYAL
EDUCATION

DANYAL
EDUCATION

$$(b) \quad \frac{1}{\sqrt{25^{2x+1}}} + \frac{10}{5^{x+2}} = 3.$$

[4]

$$\frac{1}{\sqrt{25^{2x+1}}} + \frac{10}{5^{x+2}} = 3$$

$$(25^{2x+1})^{\frac{1}{2}} + 10(5^{-x-2}) = 3$$

$$(5^2)^{-x-\frac{1}{2}} + 10(5^{-x})(5^{-2}) = 3$$

$$5^{-2x-1} + \frac{10}{25}(5^{-x}) = 3$$

$$(5^{-2x})(5^{-1}) + \frac{2}{5}(5^{-x}) = 3$$

$$5^{-2x} + 2(5^{-x}) = 15$$

$$(5^{-x})^2 + 2(5^{-x}) = 15$$

Let $u = 5^x$

$$15u^2 - 2u - 1 = 0$$

$$(3u - 1)(5u + 1) = 0$$

$$u = \frac{1}{3} \quad \text{or} \quad u = -\frac{1}{5}$$

$$5^x = \frac{1}{3} \quad \text{or} \quad 5^x = -\frac{1}{5} \text{ (N.A.)}$$

$$x = \frac{\ln \frac{1}{3}}{\ln 5} = -0.683$$

- 13 The sketch shows the graphs of the curve, $y = \frac{1}{x-1} - 3$, the lines $3y = 4x - 9$ and $y = 3$. The curve and the line $3y = 4x - 9$ intersect at P . The curve cuts the x -axis at $R\left(\frac{4}{3}, 0\right)$. The line $3y = 4x - 9$ cuts the x -axis at $Q\left(2\frac{1}{4}, 0\right)$.

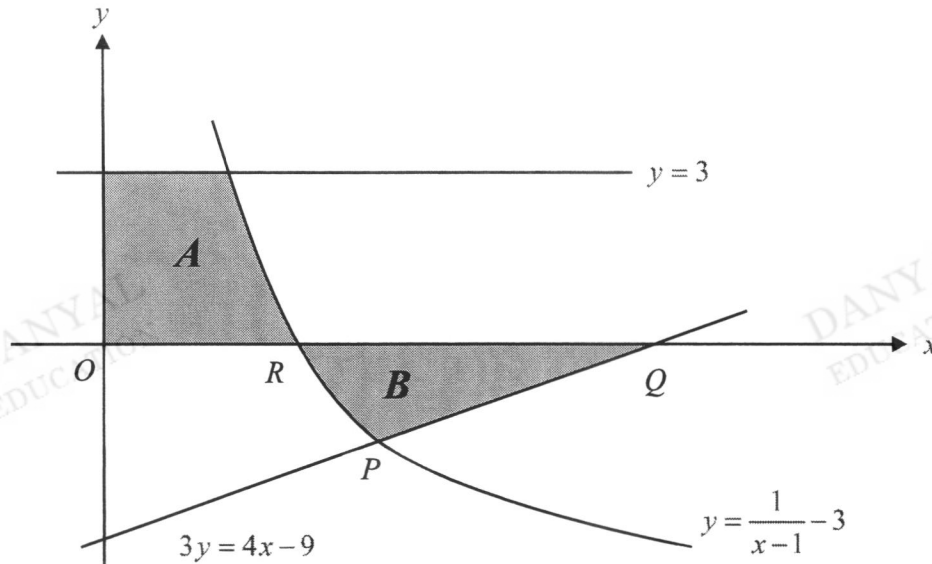

The region A is bounded by the curve, $y = \frac{1}{x-1} - 3$, the line $y = 3$ and the y -axis.

The region B is bounded by the curve, the line $3y = 4x - 9$, and the x -axis.

- (i) Verify that the coordinates of P are $\left(\frac{3}{2}, -1\right)$.

[2]

Solve simultaneous,

$$3\left(\frac{1}{x-1} - 3\right) = 4x - 9$$

$$\frac{3}{x-1} = 4x$$

$$4x^2 - 4x - 3 = 0$$

$$(2x-3)(2x+1) = 0$$

$$2x-3=0$$

$$2x+1=0$$

$$x = \frac{3}{2}$$

$$\text{or } x = -\frac{1}{2} \text{ (N.A.)}$$

$$x = \frac{3}{2}, 3y = 4\left(\frac{3}{2}\right) - 9, y = -1$$

$$P\left(\frac{3}{2}, -1\right)$$

(ii) Find the area of A and of B .

[6]

$$\begin{aligned}
 \text{Area } A &= \int_0^3 \left(\frac{1}{y+3} + 1 \right) dy \\
 &= \left[\ln(y+3) + y \right]_0^3 \\
 &= (\ln(3+3) + 3) - (\ln(0+3) + 0) \\
 &= \ln 6 - \ln 3 + 3 \\
 &= \ln 2 + 3 \\
 &= 3.69 \text{ units}^2 \text{ (3 s.f.)}
 \end{aligned}$$

$$\begin{aligned}
 \text{Area } B &= \left| \int_{\frac{4}{3}}^{\frac{3}{2}} \left(\frac{1}{x-1} - 3 \right) dx \right| + \frac{1}{2} \times \left(2 \frac{1}{4} - \frac{3}{2} \right) \times 1 \\
 &= \left| \left[\ln(x-1) - 3x \right]_{\frac{4}{3}}^{\frac{3}{2}} \right| + \frac{3}{8} \\
 &= \left| \left(\ln\left(\frac{3}{2}-1\right) - 3\left(\frac{3}{2}\right) \right) - \left(\ln\left(\frac{4}{3}-1\right) - 3\left(\frac{4}{3}\right) \right) \right| + \frac{3}{8} \\
 &= \left| \left(\ln\left(\frac{1}{2}\right) - \left(\frac{9}{2}\right) \right) - \left(\ln\left(\frac{1}{3}\right) - 4 \right) \right| + \frac{3}{8} \\
 &= \left| \left(\ln\left(\frac{3}{2}\right) - \frac{1}{2} \right) \right| + \frac{3}{8} \\
 &= 0.470 \text{ units}^2 \text{ (3 s.f.)}
 \end{aligned}$$

- 14 A vessel is in the shape of a right circular cone.
The radius of cone is 8 cm and the height is 32 cm.
Water is poured into the vessel at a rate of $10 \text{ cm}^3/\text{s}$.

Calculate the rate at which the water level is rising when the vessel is $\frac{1}{8}$ full. [4]

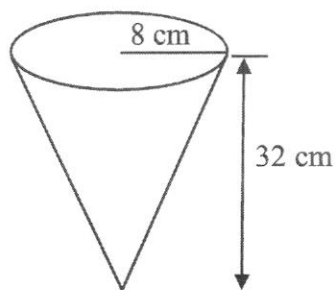

Using similar triangles

$$\frac{r}{h} = \frac{8}{32}$$

$$r = \frac{1}{4}h$$

$$V = \frac{1}{3}\pi r^2 h$$

$$= \frac{1}{3}\pi \left(\frac{h}{4}\right)^2 h$$

$$V = \frac{1}{48}\pi h^3$$

$$\frac{dV}{dh} = \frac{1}{16}\pi h^2$$

$$\frac{v}{V} = \left(\frac{h}{H}\right)^3$$

$$\frac{1}{8} = \left(\frac{h}{32}\right)^3$$

$$h = 16$$

$$\frac{dV}{dt} = \frac{dV}{dh} \times \frac{dh}{dt}$$

$$10 = \frac{1}{16}\pi(16)^2 \times \frac{dh}{dt}$$

$$\frac{dh}{dt} = 10 \div 16\pi$$

$$\frac{dh}{dt} = \frac{5}{8\pi} \text{ cm/s} \quad \text{or} \quad 0.199 \text{ cm/s}$$

END OF PAPER

Name: Solutions	Register No.:	Class:
------------------------	----------------------	---------------



**CRESCENT GIRLS' SCHOOL
SECONDARY FOUR 2023
PRELIMINARY EXAMINATION**

**ADDITIONAL MATHEMATICS
Paper 2**

**4049/02
25 August 2023**

Candidates answer on the Question Paper.
No Additional Materials are required.

2 hours 15 mins

READ THESE INSTRUCTIONS FIRST

Write your name and index number on all the work you hand in.
Write in dark blue or black pen on both sides of the paper.
You may use an HB pencil for any diagrams or graphs.
Do not use staples, paper clips, glue or correction fluid.

Answer **all** questions.

If working is needed for any question it must be shown with the answer.

Omission of essential working will result in loss of marks.

The use of an approved scientific calculator is expected, where appropriate.

If the degree of accuracy is not specified in the question, and if the answer is not exact, give the answer to three significant figures. Give answers in degrees to one decimal place.

For π , use either your calculator value or 3.142, unless the question requires the answer in terms of π .

At the end of the examination, fasten all your work securely together.

The number of marks is given in brackets [] at the end of each question or part question.

The total of the marks for this paper is **90**.

For Examiner's Use

Question	1	2	3	4	5	6	7	8	9	10	11
Marks											

Table of Penalties		Qn. No.	90
Presentation	-1		
Significant Figures/ Units	-1	Parent's/Guardian's Signature	

This document consists of **20** printed pages.

Mathematical Formulae**1. ALGEBRA***Quadratic Equation*

For the equation $ax^2 + bx + c = 0$,

$$x = \frac{-b \pm \sqrt{b^2 - 4ac}}{2a}$$

Binomial expansion

$$(a+b)^n = a^n + \binom{n}{1}a^{n-1}b + \binom{n}{2}a^{n-2}b^2 + \dots + \binom{n}{r}a^{n-r}b^r + \dots + b^n,$$

where n is a positive integer and $\binom{n}{r} = \frac{n!}{r!(n-r)!} = \frac{n(n-1)\dots(n-r+1)}{r!}$

2. TRIGONOMETRY*Identities*

$$\sin^2 A + \cos^2 A = 1$$

$$\sec^2 A = 1 + \tan^2 A$$

$$\operatorname{cosec}^2 A = 1 + \cot^2 A$$

$$\sin(A \pm B) = \sin A \cos B \pm \cos A \sin B$$

$$\cos(A \pm B) = \cos A \cos B \mp \sin A \sin B$$

$$\tan(A \pm B) = \frac{\tan A \pm \tan B}{1 \mp \tan A \tan B}$$

$$\sin 2A = 2 \sin A \cos A$$

$$\cos 2A = \cos^2 A - \sin^2 A = 2 \cos^2 A - 1 = 1 - 2 \sin^2 A$$

$$\tan 2A = \frac{2 \tan A}{1 - \tan^2 A}$$

Formulae for $\triangle ABC$

$$\frac{a}{\sin A} = \frac{b}{\sin B} = \frac{c}{\sin C}$$

$$a^2 = b^2 + c^2 - 2bc \cos A$$

$$\Delta = \frac{1}{2} ab \sin C$$

1 (i) The equation of a curve is $f(x) = \frac{\sqrt{x^2+1}}{3x+4}$, $x \neq p$.

Find $f'(x)$, simplifying your answer as a single fraction. Hence determine the gradient of the tangent at the point on the curve where $x = 0$. [5]

$$f'(x) = \frac{(3x+4) \cdot \frac{1}{2}(x^2+1)^{-\frac{1}{2}}(2x) - (x^2+1)^{\frac{1}{2}}(3)}{(3x+4)^2}$$

$$= \frac{\frac{x(3x+4)}{\sqrt{x^2+1}} - 3\sqrt{x^2+1}}{(3x+4)^2}$$

$$= \frac{x(3x+4) - 3(x^2+1)}{\sqrt{x^2+1}(3x+4)^2}$$

$$= \frac{4x-3}{\sqrt{x^2+1}(3x+4)^2}$$

When $x = 0$, gradient of tangent is $\frac{4(0)-3}{\sqrt{0^2+1}(3(0)+4)^2}$

$$= -\frac{3}{16}$$

(ii) State the value of p .

[1]

$$p = -1\frac{1}{3}$$

- 2 By using a suitable substitution, show that $3e^{\sqrt{4x}} - 4 = e^{\sqrt{x}}$ has only one solution and find its value correct to 2 significant figures. [5]

$$3(e^{\sqrt{x}})^2 - 4 = e^{\sqrt{x}}$$

$$\text{Let } y = e^{\sqrt{x}}$$

$$3y^2 - y - 4 = 0$$

$$(3y - 4)(y + 1) = 0$$

$$y = \frac{4}{3} \text{ or } y = -1$$

$$e^{\sqrt{x}} = \frac{4}{3} \text{ or } e^{\sqrt{x}} = -1 \text{ (NA since } e^{\sqrt{x}} > 0)$$

$$\sqrt{x} = \ln \frac{4}{3} \Rightarrow x = 0.083 \text{ (to 2 s.f.)}$$

- 3 The diagram below shows a circle $x^2 + y^2 = 9$ and a straight line $y = kx + 5$.
Find the range of values of k .

[5]

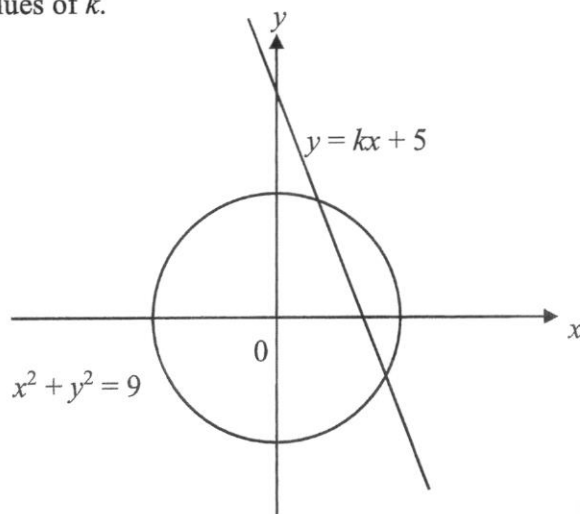

Sub $y = kx + 5$ into $x^2 + y^2 = 9$

$$x^2 + (kx + 5)^2 = 9$$

$$x^2 + k^2x^2 + 10kx + 25 - 9 = 0$$

$$x^2(1 + k^2) + 10kx + 16 = 0$$

Since line cuts the curve at 2 distinct points, $b^2 - 4ac > 0$.

$$(10k)^2 - 4(1 + k^2)(16) > 0$$

$$100k^2 - 64 - 64k^2 > 0$$

$$4(9k^2 - 16) > 0$$

$$(3k + 4)(3k - 4) > 0$$

$$k < -\frac{4}{3} \text{ or } k > \frac{4}{3}$$

Since $k < 0$, $k < -\frac{4}{3}$.

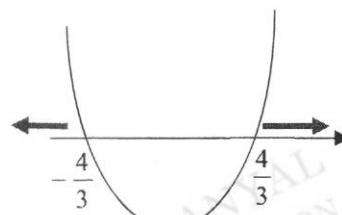

4 (a) Show that $\frac{d}{dx} \ln(\sin x + \cos x) = \tan\left(\frac{\pi}{4} - x\right)$. [4]

$$\begin{aligned} \frac{d}{dx} \ln(\sin x + \cos x) &= \frac{1}{\sin x + \cos x} \frac{d}{dx} (\sin x + \cos x) \\ &= \frac{\cos x - \sin x}{\sin x + \cos x} \\ &= \frac{\frac{\cos x}{\cos x} - \frac{\sin x}{\cos x}}{\frac{\sin x}{\cos x} + \frac{\cos x}{\cos x}} \\ &= \frac{1 - \tan x}{1 + \tan x} \\ &= \frac{\tan \frac{\pi}{4} - \tan x}{\tan \frac{\pi}{4} + \tan x} \\ &= \tan\left(\frac{\pi}{4} - x\right) \quad (\text{shown}) \end{aligned}$$

(b) Solve $\tan\left(\frac{\pi}{4} - x\right) = -3$ for $0 \leq x \leq \pi$. [2]

$$\tan\left(\frac{\pi}{4} - x\right) = -3$$

$$\tan\left[-\left(x - \frac{\pi}{4}\right)\right] = -3$$

$$\tan\left(x - \frac{\pi}{4}\right) = 3$$

Basic angle = 1.2490

$$x - \frac{\pi}{4} = 1.2490$$

$$x = 2.03 \quad (\text{to 3 s.f.})$$

5 (i) Differentiate $3x \cos \frac{1}{2}x$ with respect to x .

[3]

$$\begin{aligned} \frac{d}{dx} 3x \cos \frac{1}{2}x &= 3x \frac{d}{dx} \left(\cos \frac{1}{2}x \right) + \left(\cos \frac{1}{2}x \right) \frac{d}{dx} (3x) \\ &= 3x \left(-\frac{1}{2} \sin \frac{1}{2}x \right) + \left(\cos \frac{1}{2}x \right) 3 \\ &= -\frac{3}{2}x \sin \frac{1}{2}x + 3 \cos \frac{1}{2}x \end{aligned}$$

(ii) Hence, find the exact value of $\int_0^{\frac{\pi}{3}} x \sin \frac{1}{2}x \, dx$.

[4]

$$\begin{aligned} \frac{d}{dx} 3x \cos \frac{1}{2}x &= -\frac{3}{2}x \sin \frac{1}{2}x + 3 \cos \frac{1}{2}x \\ \frac{3}{2}x \sin \frac{1}{2}x &= 3 \cos \frac{1}{2}x - \frac{d}{dx} 3x \cos \frac{1}{2}x \\ x \sin \frac{1}{2}x &= 2 \cos \frac{1}{2}x - \frac{d}{dx} 2x \cos \frac{1}{2}x \\ \int_0^{\frac{\pi}{3}} x \sin \frac{1}{2}x \, dx &= \int_0^{\frac{\pi}{3}} 2 \cos \frac{1}{2}x \, dx - \left[2x \cos \frac{1}{2}x \right]_0^{\frac{\pi}{3}} \\ &= \left[4 \sin \frac{1}{2}x - 2x \cos \frac{1}{2}x \right]_0^{\frac{\pi}{3}} \\ &= 4 \sin \frac{1}{2} \left(\frac{\pi}{3} \right) - 2 \left(\frac{\pi}{3} \right) \cos \frac{\pi}{6} \\ &= 4 \left(\frac{1}{2} \right) - \frac{2\pi}{3} \left(\frac{\sqrt{3}}{2} \right) \\ &= 2 - \frac{\sqrt{3}\pi}{3} \end{aligned}$$

- 6 The figure (not drawn to scale) shows a right-angled triangle ABC constructed between two parallel lines.

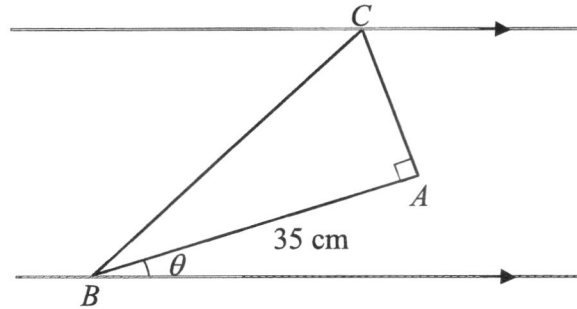

The area of triangle ABC is 210 cm^2 . $AB = 35 \text{ cm}$ and makes an acute angle θ with one of the lines.

- (i) Show that the distance between the parallel lines, $d = (12 \cos \theta + 35 \sin \theta) \text{ cm}$. [2]

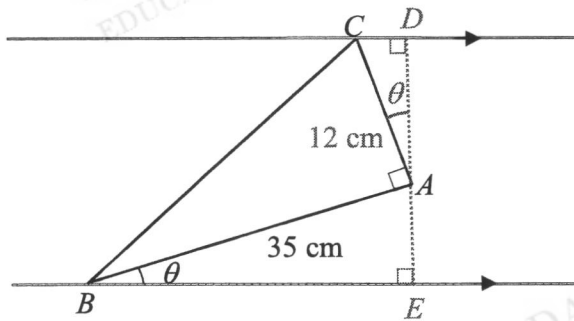

$$\frac{1}{2}(350)(AC) = 210$$

$$AC = 12 \text{ cm}$$

$$\cos \theta = \frac{AD}{12} \Rightarrow AD = 12 \cos \theta$$

$$\sin \theta = \frac{AE}{35} \Rightarrow AE = 35 \sin \theta$$

$$d = AD + AE$$

$$= (12 \cos \theta + 35 \sin \theta) \text{ cm}$$

- (ii) Express d in the form $R \cos(\theta - \alpha)$, where R is a constant and α is an angle in radians. [3]

$$12 \cos \theta + 35 \sin \theta = R \cos(\theta - \alpha)$$

$$R = \sqrt{12^2 + 35^2}$$

$$= 37$$

$$\alpha = \tan^{-1}\left(\frac{35}{12}\right)$$

$$= 1.2405$$

$$d = 37 \cos(\theta - 1.24)$$

- (iii) Find the value of θ when $d = 28$ cm. [2]

$$37 \cos(\theta - 1.2405) = 28$$

$$\cos(\theta - 1.2405) = \frac{28}{37}$$

$$\text{Basic angle} = 0.71246$$

$$\theta - 1.2405 = 0.71246 \quad (\text{rejected})$$

$$\theta - 1.2405 = 2\pi - 0.71246 - 2\pi$$

$$\theta - 1.2405 = -0.71246 \quad \Rightarrow \theta = 0.528 \quad (\text{to 3 s.f.})$$

7 The coefficient of $\frac{1}{x^3}$ is 512 in the expansion of $\left(\frac{2}{x} + px^2\right)^9$, where $p < 0$.

(i) By first working out the general term of $\left(\frac{2}{x} + px^2\right)^9$, find the value of p . [3]

$$\left(\frac{2}{x} + px^2\right)^9$$

$$\begin{aligned} T_{r+1} &= \binom{9}{r} \left(\frac{2}{x}\right)^{9-r} (px^2)^r \\ &= \binom{9}{r} (2)^{9-r} (p^r) x^{3r-9} \end{aligned}$$

For the term in $\frac{1}{x^3}$, $3r - 9 = -3$

$$r = 2$$

$$\binom{9}{2} (2)^7 (p^2) = 512$$

$$p^2 = \frac{1}{9}$$

$$p = \frac{1}{3} \text{ (rejected since } p < 0) \text{ or } p = -\frac{1}{3}$$

(ii) Using the results in (i),

(a) show that the coefficient of the first term in the expansion of $\left(\frac{2}{x} + px^2\right)^9$ is also 512. [1]

$$T_{r+1} = \binom{9}{r} (2)^{9-r} \left(-\frac{1}{3}\right)^r x^{3r-9}$$

First term, $r = 0$

$$\text{Coeff. of } T_1 = \binom{9}{0} (2)^9 \left(-\frac{1}{3}\right)^0 = 512 \text{ (shown)}$$

- (b) find the $\frac{1}{x^6}$ term in the expansion of $\left(\frac{2}{x} + px^2\right)^9$. [2]

For $\frac{1}{x^6}$ term, $3r - 9 = -6$
 $r = 1$

$$T_2 = \binom{9}{1} (2)^{9-1} \left(-\frac{1}{3}\right)^1 x^{-6}$$

$$= -\frac{768}{x^6}$$

- (c) explain why the term in $\frac{1}{x^4}$ does not exist in the expansion of

$$\left(\frac{2}{x} + px^2\right)^9 \left(\frac{1}{8x} + \frac{1}{12}x^2\right). \quad [2]$$

$$\left(\frac{2}{x} - \frac{x^2}{3}\right)^9 \left(\frac{1}{8x} + \frac{x^2}{12}\right)$$

$$= \left(\dots + \frac{512}{x^3} - \frac{768}{x^6} + \dots\right) \left(\frac{1}{8x} + \frac{x^2}{12}\right)$$

$$\text{Coefficient of } \frac{1}{x^4} = 512\left(\frac{1}{8}\right) - 768\left(\frac{1}{12}\right)$$

$$= 0$$

Hence the the term in $\frac{1}{x^4}$ does not exist in the expansion of

$$\left(\frac{2}{x} + px^2\right)^9 \left(\frac{1}{8x} + \frac{1}{12}x^2\right).$$

- 8 The diagram below shows the curve $y = \ln(x+3)^4$ which cuts the y -axis at $(0, 4 \ln b)$. The line l_1 , cuts the y -axis at $(0, -2)$ and meets the curve at $(-1, 4 \ln a)$.

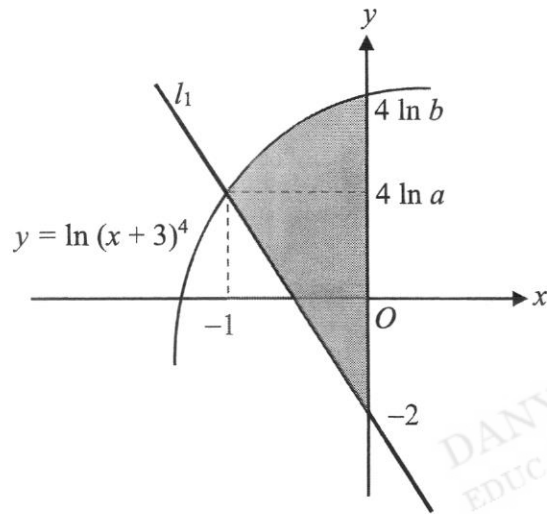

- (i) Find the value of a and of b .

[2]

$$\begin{aligned} y = \ln(x+3)^4 \text{ cuts the } y\text{-axis,} \\ 4 \ln(0+3) = 4 \ln b \\ b = 3 \end{aligned}$$

$$\begin{aligned} \text{When } x = -1, \\ 4 \ln(-1+3) = 4 \ln a \\ a = 2 \end{aligned}$$

- (ii) Find the equation of l_1 giving your answer in the form $y = (p \ln q + r)x + s$ where p , q , r and s are integers. [2]

$$\text{Gradient of } l_1 \text{ is } \frac{4 \ln 2 - (-2)}{-1 - 0} = -4 \ln 2 - 2$$

$$\text{Equation of } l_1 \text{ is } y = (-4 \ln 2 - 2)x - 2$$

- (iii) Calculate the area of the shaded region, giving your answer to 3 decimal places. [6]

$$y = 4 \ln(x + 3)$$

$$e^{\frac{y}{4}} = x + 3$$

$$x = e^{\frac{y}{4}} - 3$$

Area of shaded region

$$= \frac{1}{2}(4 \ln 2 + 2)(1) + \left[-\int_{4 \ln 2}^{4 \ln 3} \left(e^{\frac{y}{4}} - 3 \right) dy \right]$$

$$= 2 \ln 2 + 1 - \left[4e^{\frac{y}{4}} - 3y \right]_{4 \ln 2}^{4 \ln 3}$$

$$= 2 \ln 2 + 1 - \left[4e^{\frac{4 \ln 3}{4}} - 3(4 \ln 3) - \left(4e^{\frac{4 \ln 2}{4}} - 3(4 \ln 2) \right) \right]$$

$$= 2 \ln 2 + 1 - 4(3) + 12 \ln 3 + 4(2) - 12 \ln 2$$

$$= 3.252 \text{ units}^2 \text{ (to 3 d.p.)}$$

- 9 Two particles, P and Q , each moving in a straight line passes a point, Z , at the same instant. The displacement of P , s_P m is given by $s_P = \frac{t^3}{3} - \frac{3t^2}{2} + 5t$ where t is the time in seconds after passing Z .

The particle Q passes Z with a velocity of 11 m/s and its acceleration, a_Q m/s² is given by $a_Q = 2t - 6$ where t is the time in seconds after passing Z .

- (a) Find the value of t for which the velocities of P and Q are equal. [4]

$$s_P = \frac{t^3}{3} - \frac{3t^2}{2} + 5t$$

$$v_P = \frac{ds_P}{dt} = t^2 - 3t + 5$$

$$a_Q = 2t - 6$$

$$v_Q = \int 2t - 6 \, dt$$

$$= t^2 - 6t + c, \text{ where } c \text{ is an arbitrary constant}$$

$$\text{When } t = 0, v_Q = 11, c = 11$$

$$v_Q = t^2 - 6t + 11$$

$$v_P = v_Q$$

$$t^2 - 3t + 5 = t^2 - 6t + 11$$

$$3t = 6 \Rightarrow t = 2$$

- (b) Explain why particle Q will always move in the same direction after passing Z . [2]

$$\begin{aligned} v_Q &= t^2 - 6t + 11 \\ &= t^2 - 6t + 3^2 - 3^2 + 11 \\ &= (t-3)^2 + 2 \end{aligned}$$

For all $t > 0$, $(t-3)^2 > 0$, $(t-3)^2 + 2 \geq 2$.

Since $(t-3)^2 + 2 > 0$, $v > 0$.

Q will always move in the same direction after passing Z .

Alternative method

$$v_Q = t^2 - 6t + 11$$

$$\begin{aligned} b^2 - 4ac &= (-6)^2 - 4(1)(11) \\ &= -8 < 0 \end{aligned}$$

OR

Since $b^2 - 4ac < 0$ and $a > 0$, v_Q is always

$t^2 - 6t + 11 = 0$ has no real values of t implying that Q will not come to instantaneous rest. Hence Q will always move in the same direction after passing Z .

- (c) Determine, with explanation, if there is any instance when particle Q is ahead of particle P . [4]

$$s_Q = \int t^2 - 6t + 11 \, dt$$

$$= \frac{t^3}{3} - 3t^2 + 11t + d, \text{ where } d \text{ is an arbitrary constant}$$

When $t = 0$, $s_Q = 0$, $d = 0$

$$s_Q = \frac{t^3}{3} - 3t^2 + 11t$$

$$s_Q - s_P = \frac{t^3}{3} - 3t^2 + 11t - \left(\frac{t^3}{3} - \frac{3t^2}{2} + 5t \right)$$

$$= -\frac{3t^2}{2} + 6t$$

$$= \frac{3}{2}t(4-t)$$

When Q overtakes P , $s_Q - s_P > 0$

$$\frac{3}{2}t(4-t) > 0$$

$$\frac{3}{2}t(4-t) > 0$$

$$0 < t < 4$$

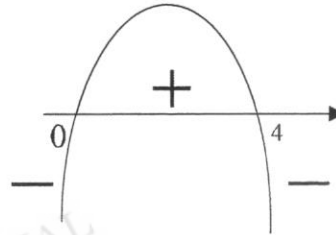

Particle Q is ahead of particle P when $0 < t < 4$.

- (d) Find the average velocity of particle Q in the first 5 seconds. [2]

$$\text{When } t = 5, s_Q = \frac{5^3}{3} - 3(5)^2 + 11(5)$$

$$= 21\frac{2}{3} \text{ m}$$

$$\text{Average velocity of particle } Q \text{ in the first 5 seconds} = 21\frac{2}{3} \div 5$$

$$= 4\frac{1}{3} \text{ m/s}$$

- 10 The diagram shows two circles C_1 and C_2 .

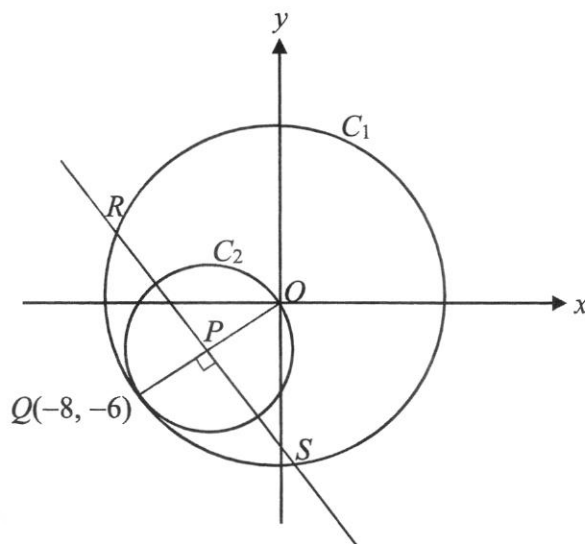

C_1 has its centre at the origin O while C_2 passes through O and has its centre at P . The point $Q(-8, -6)$ lies on both circles and OQ is the diameter of C_2 .

- (i) Find the equations of C_1 and C_2 .

[5]

$$\begin{aligned} \text{Radius of } C_1: OQ &= \sqrt{(-8)^2 + (-6)^2} \\ &= 10 \text{ units} \end{aligned}$$

$$\text{Equation of } C_1 \text{ is } x^2 + y^2 = 100.$$

$$\text{Coordinates of } P = \left(\frac{0 + (-8)}{2}, \frac{0 + (-6)}{2} \right) = (-4, -3)$$

$$\begin{aligned} \text{Radius of } C_2: OP &= \frac{1}{2}(10) \\ &= 5 \text{ units} \end{aligned}$$

$$\text{Equation of } C_2 \text{ is } (x+4)^2 + (y+3)^2 = 25.$$

The line through P perpendicular to OQ meets the circle C_1 at the points R and S .

- (ii) Show that the x -coordinates of R and S are $a - b\sqrt{3}$ and $a + b\sqrt{3}$ respectively, where a and b are integers to be determined. [7]

$$\text{Gradient of } OQ = \frac{-6}{-8} = \frac{3}{4}$$

$$\therefore \text{ gradient of } RS = -\frac{4}{3}$$

$$\text{Equation of } RS \text{ is } y + 3 = -\frac{4}{3}(x + 4)$$

$$y = -\frac{4}{3}x - \frac{25}{3}$$

$$y = -\frac{4}{3}x - \frac{25}{3} \quad \text{----- (1)}$$

$$x^2 + y^2 = 10 \quad \text{----- (2)}$$

Sub (1) into (2):

$$x^2 + \left(-\frac{4}{3}x - \frac{25}{3}\right)^2 = 100$$

$$x^2 + \frac{16}{9}x^2 + \frac{200}{9}x + \frac{625}{9} - 100 = 0$$

$$\frac{25}{9}x^2 + \frac{200}{9}x - \frac{275}{9} = 0$$

$$x^2 + 8x - 11 = 0$$

$$x = \frac{-8 \pm \sqrt{64 - 4(-11)}}{2}$$

$$= \frac{-8 \pm 6\sqrt{3}}{2}$$

$$= -4 \pm 3\sqrt{3}$$

x -coordinates of R and S are $-4 - 3\sqrt{3}$ and $-4 + 3\sqrt{3}$ respectively where $a = -4$ and $b = 3$.

- 11 (a) The population P , in millions of a city, recorded in the month of January for various years is modelled by the equation $P = 10 + at^n$, where t is the time measured in years from January 2002 and a and n are constants.

The values are tabulated below.

Year	2005	2012	2017	2022
P	20.4	73.2	126.2	188.9

- (i) On the grid opposite, plot $\lg(P-10)$ against $\lg t$ for the given data and draw a straight-line graph to estimate the values of a and n , giving your answers to one decimal place. [6]

$$\lg(P-10) = \lg at^n$$

$$\lg(P-10) = n \lg t + \lg a$$

Year	2005	2012	2017	2022
t	3	10	15	20
$\lg t$	0.47	1.00	1.18	1.30
$\lg(P-10)$	1.02	1.80	2.07	2.25

Correct table of values

All points plotted correctly

Best-fit straight line

$$\begin{aligned} \text{Gradient, } n &= \frac{2.10 - 1.20}{1.20 - 0.60} \\ &= 1.5 \text{ (to 1 d.p.)} \end{aligned}$$

$$\lg a = 0.3$$

$$a = 10^{0.3}$$

$$= 1.9953$$

$$= 2.0 \text{ (to 1 d.p.)}$$

- (ii) Use your graph to determine the year in which the population reached 100 millions. [2]

$$P = 100$$

$$\text{Draw } Y = \lg 90 \quad (\text{i.e. } Y = 1.95)$$

$$\lg t = 1.11$$

$$t = 10^{1.11} = 12.9$$

The year which the population reaches 100 millions is 2014.

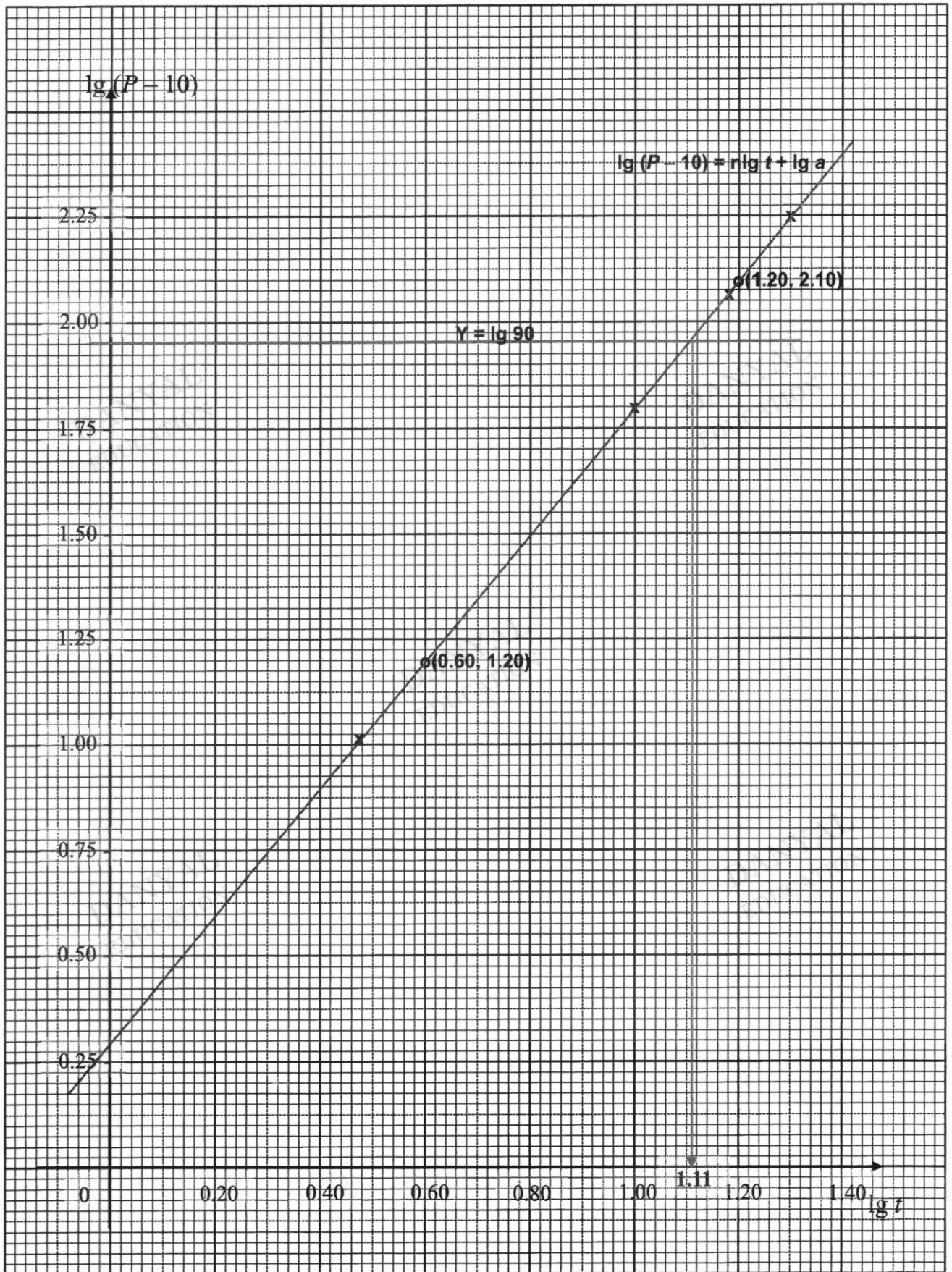

- (b) The diagram shows part of a straight-line graph, passing through the points $(2, h)$ and $(5, 4)$, and representing the equations $2x^3 + kx = 3y$, where k and h are constants. Find the value of h and of k . [4]

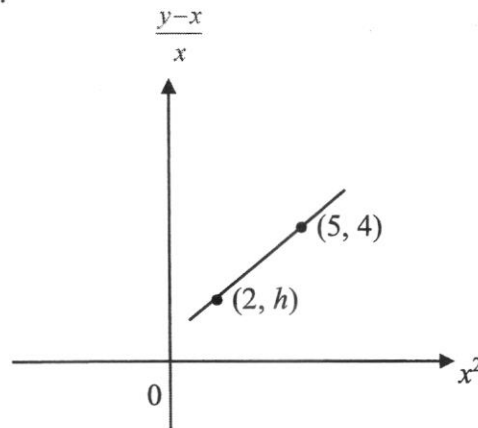

$$\text{Gradient} = \frac{4-h}{5-2} = \frac{4-h}{3}$$

$$\text{Equation of the line is } Y-4 = \frac{4-h}{3}(X-5)$$

$$\frac{y-x}{x} - 4 = \frac{4-h}{3}(x^2 - 5)$$

$$3(y-x) - 12x = (4-h)(x^2 - 5x)$$

$$3y - 3x - 12x = 4x^2 - 20x - hx^2 + 5hx$$

$$3y = (4-h)x^2 + (5h-5)x$$

$$\text{Compare with } 3y = 2x^3 + kx$$

$$4-h=2 \Rightarrow h=2$$

$$5h-5=k \Rightarrow k=5(2)-5=5$$

End of Paper