

CANDIDATE
NAME

--

CLASS

--

INDEX
NUMBER

--	--	--	--

Anglo-Chinese School (Independent)

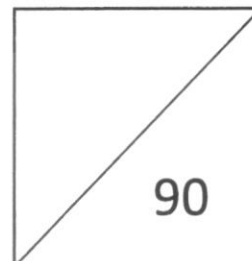

PRELIMINARY EXAMINATION 2024 YEAR FOUR EXPRESS MATHEMATICS PAPER 1

4052/01

Thursday

1 August 2024

2 hours 15 minutes

Candidates answer on the Question Paper.

READ THESE INSTRUCTIONS FIRST

Write your index number, name and class in the spaces on top of this page.

Write in dark blue or black pen.

You may use an HB pencil for any diagrams or graphs.

Do not use staples, paper clips, highlighters, glue or correction fluid.

Answer **all** questions.

If working is needed for any question, it must be shown with the answer.

Omission of essential working will result in loss of marks.

The use of an approved scientific calculator is expected, where appropriate.

If the degree of accuracy is not specified in the question, and if the answer is not exact, give the answer to three significant figures. Give answers in degrees to one decimal place.

For π , use either your calculator value or 3.142, unless the question requires the answer in terms of π .

The number of marks is given in brackets [] at the end of each question or part question.

The total number of marks for this paper is 90.

Mathematical Formulae*Compound Interest*

$$\text{Total amount} = P \left(1 + \frac{r}{100} \right)^n$$

Mensuration

$$\text{Curved surface area of a cone} = \pi r l$$

$$\text{Surface area of a sphere} = 4 \pi r^2$$

$$\text{Volume of a cone} = \frac{1}{3} \pi r^2 h$$

$$\text{Volume of a sphere} = \frac{4}{3} \pi r^3$$

$$\text{Area of a triangle} = \frac{1}{2} ab \sin C$$

$$\text{Arc length} = r\theta, \text{ where } \theta \text{ is in radians}$$

$$\text{Sector area} = \frac{1}{2} r^2 \theta, \text{ where } \theta \text{ is in radians}$$

Trigonometry

$$\frac{a}{\sin A} = \frac{b}{\sin B} = \frac{c}{\sin C}$$

$$a^2 = b^2 + c^2 - 2bc \cos A$$

Statistics

$$\text{Mean} = \frac{\sum fx}{\sum f}$$

$$\text{Standard deviation} = \sqrt{\frac{\sum fx^2}{\sum f} - \left(\frac{\sum fx}{\sum f} \right)^2}$$

3

Answer **all** the questions.1 The point C lies on the line AB such $AC:AB = 2:7$.(a) Write AC as a fraction of BC .

studykaki.com

Answer [1]

(b) Given that AC is 24 cm, calculate the length of BC .studykaki.com
Answer cm [1]2 (a) $\sin x^\circ = 0.66913$
Given that x is an obtuse angle, find x .

studykaki.com

Answer $x =$ [1](b) $\cos y^\circ = -\cos 121^\circ$
Given that y is an acute angle, find the value of y .

studykaki.com

Answer $y =$ [1]

- 3 During a game, Lee rolled two fair six-sided die. To obtain the score, he subtracted the lower number from the higher number. If the numbers shown on the dice were the same, his score is zero.

(a) Construct a possibility diagram to show all possible outcomes. [1]

Answer

studykaki.com

studykaki.com

(b) Find the probability that Lee's score is 5.

Answer [1]

studykaki.com

- 4 A shopkeeper bought a pair of shorts for \$24. He made a percentage profit of 45% despite selling it at a discount of 20% off the listed price. Calculate the listed price for this pair of shorts.

studykaki.com

Answer \$..... [2]

5

- 5 Part of the graph of a quadratic function is shown below.

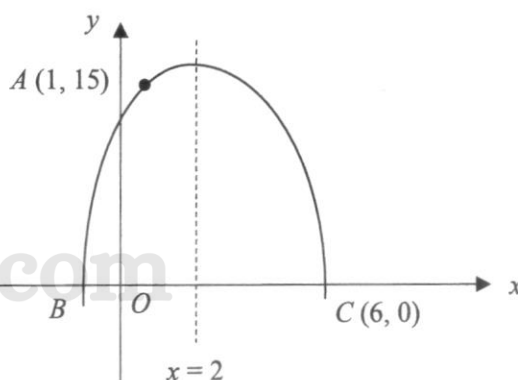

The graph passes through the point $A(1, 15)$ and it cuts the x -axis at the points B and C .
Given that C is $(6, 0)$ and $x = 2$ is the line of symmetry of the graph,

- (a) write down the equation of the quadratic curve in the form $y = a(x - h)^2 + k$.

studykaki.com

studykaki.com

Answer [2]

- (b) find the positive value of x when $y = 4$, leaving your answer in exact form.

studykaki.com

Answer $x =$ [1]

6 Justin drew this graph to show his mobile data usage for each of the following four months.

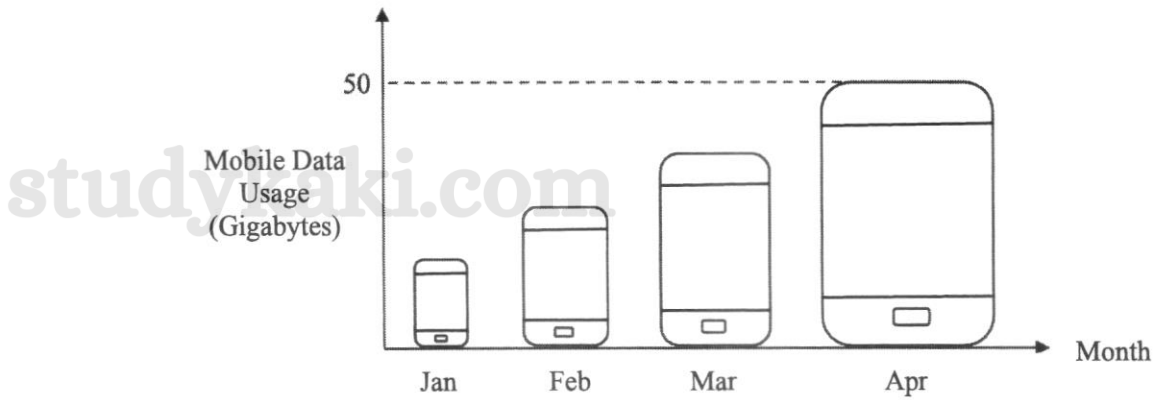

State one aspect of the graph that may be misleading and explain how this may lead to a misinterpretation of the graph.

Answer

.....

.....

..... [2]

studykaki.com

7 Simplify $\left(\frac{1}{2}x^2\right)^3 \div (4\sqrt[3]{x^5})$ giving your answer in the form of ax^n , where a and n are rational numbers.

studykaki.com

Answer [2]

- 8 (a) Express 13 824 as a product of its prime factors.

studykaki.com

Answer [1]

- (b) Explain why 13 824 is a perfect cube.

Answer

.....

.....

..... [1]

studykaki.com

- (c) Given that a is a prime number, find the value of a such that $\frac{1}{8a} \times 13824$ is a perfect square.

studykaki.com

studykaki.com

Answer $a =$ [1]

9 In the diagram, $ABCD$ is a rectangle and E and F are points on AD and BC respectively.

The ratio of the area of triangle ABF to the area of rectangle $ABCD$ is $1:9$.

The ratio of the area of triangle AFE to the area of rectangle $ABCD$ is $1:6$.

Explain with clear workings, if the following statements are true/ false.

studykaki.com

- A: The ratio of the area of triangle ABF to that of triangle AFE is $2:3$.
- B: The ratio of the area of triangle DFC to that of rectangle $ABCD$ is $2:5$.
- C: The sum of the area of triangles ABF and triangle DFC is equal to the sum of the area of triangles AFE and EFD .

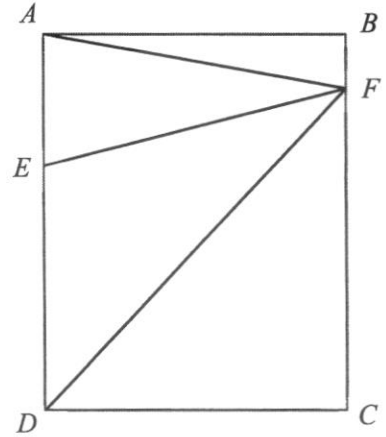

Answer

studykaki.com

studykaki.com

studykaki.com

[6]

- 10 The ratio of the number of soccer balls and volleyballs in a sports shop was 11: 7. After 126 soccer balls were added and 233 volleyballs were sold, the ratio became 14: 3. How many volleyballs were there in the shop at first?

studykaki.com

studykaki.com
Answervolleyballs [3]

- 11 Explain why $(5n + 2)^2 - (5n - 2)^2$ is a multiple of 8 for all integer values of n .

Answer

studykaki.com

studykaki.com

.....
..... [2]

10

12 Factorise the following completely.

(a) $45b - 18ab - 2a^2 + 5a,$

studykaki.com

Answer [2]

(b) $2p^2 - \frac{2}{3}p - \frac{1}{6}.$

studykaki.com

Answer [2]

13 Simplify $\frac{x^2 - 9y^2}{3x^2 + 7xy - 6y^2}.$

studykaki.com

studykaki.com

Answer [3]

14 The sets P and Q consists of the points whose coordinates (x, y) are given by $P = \{(x, y) : y = 2x + 3\}$ and $Q = \{(0, 0), (0, 3), (1, 5), (2, 5), (3, 9)\}$ respectively.

(a) List the elements in $P \cap Q$.

studykaki.com

Answer [2]

(b) Shade the region which represents $(P \cup Q)'$.

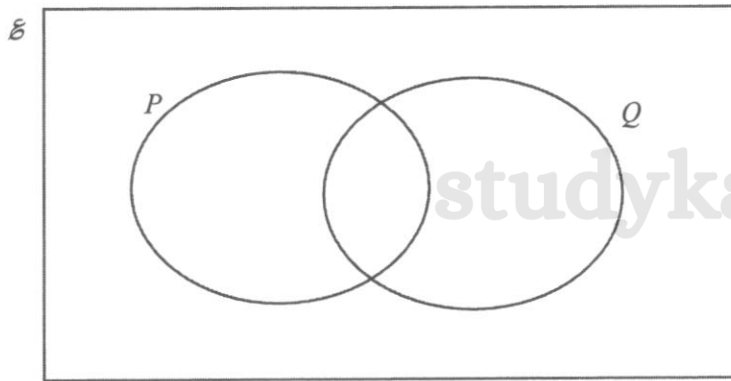

[1]

15 The distance between the points $M(k, 7)$ and $N(9, k)$ is $\sqrt{20}$ units. Given that $k > 10$, find the value of k .

studykaki.com

studykaki.com

Answer $k = \dots \dots \dots$ [3]

- 16 Mr Tan took 4 hours to travel from Town A to Town B. Mr Lim took 8 hours to travel in the opposite direction from Town B to Town A using the same route. They both started at 11am. What time did they pass each other?

studykaki.com

studykaki.com
Answer pm [2]

-
- 17 Sam and Wilson can paint a house together in 6 days. They painted the house together for 5 days and then Sam completed the painting of the remaining house alone in 3 days. How many days would it take for Wilson to paint the entire house by himself?

studykaki.com

studykaki.com

Answer days [3]

18 The cumulative frequency curve below illustrates the wait time of 240 customers who visited a bank.

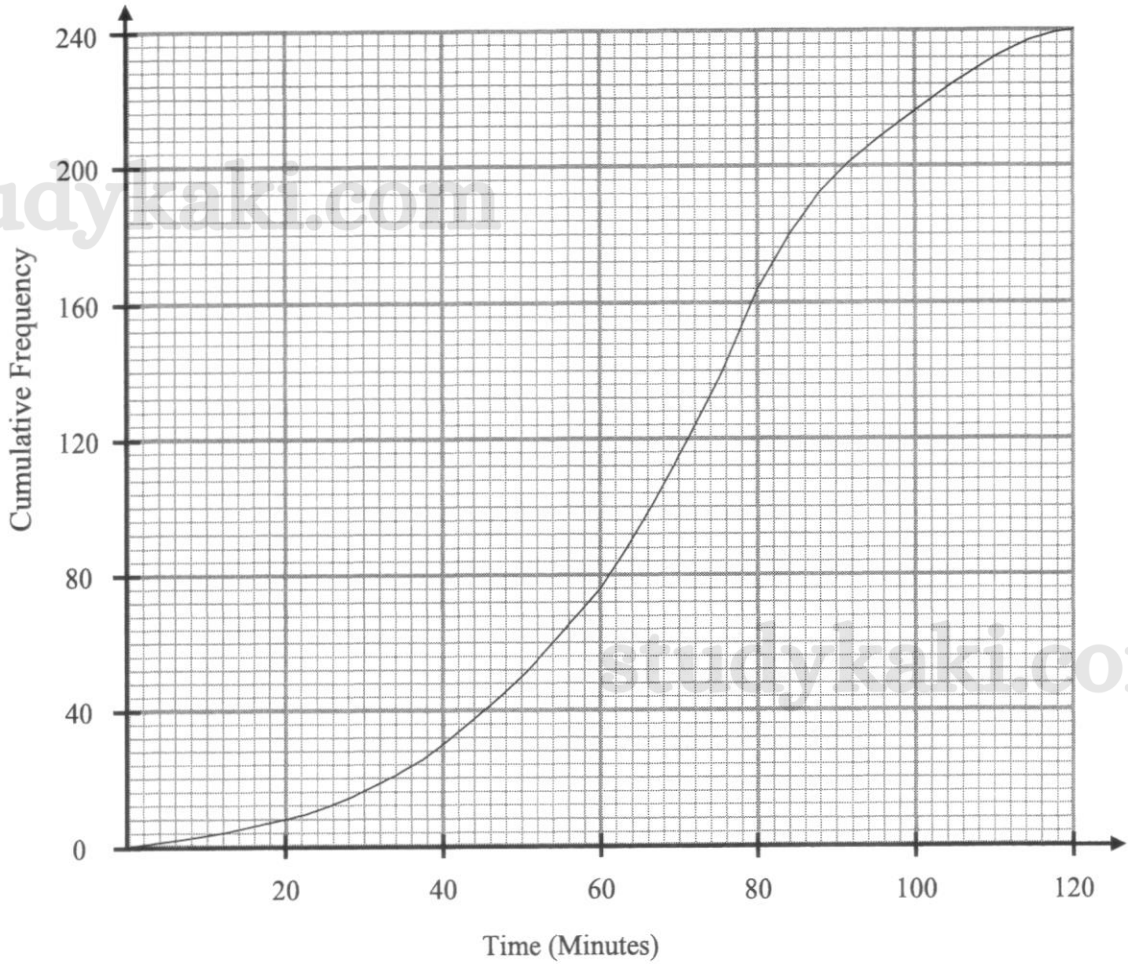

Use the graph to estimate
(a) the 60th percentile,

Answer minutes [1]

(b) the interquartile range of the wait time.

Answer minutes [2]

- (c) Only 10% of the customers complained about the long wait time they experienced. What was the minimum wait time for these customers?

studykaki.com

Answer minutes [2]

- (d) Two customers are chosen at random. Find the probability that one customer waited for less than or equal to 60 minutes and the other waited for more than 100 minutes.

studykaki.com

Answer [2]

studykaki.com

studykaki.com

19 In the diagram below, triangle ABC is congruent to triangle PNA .

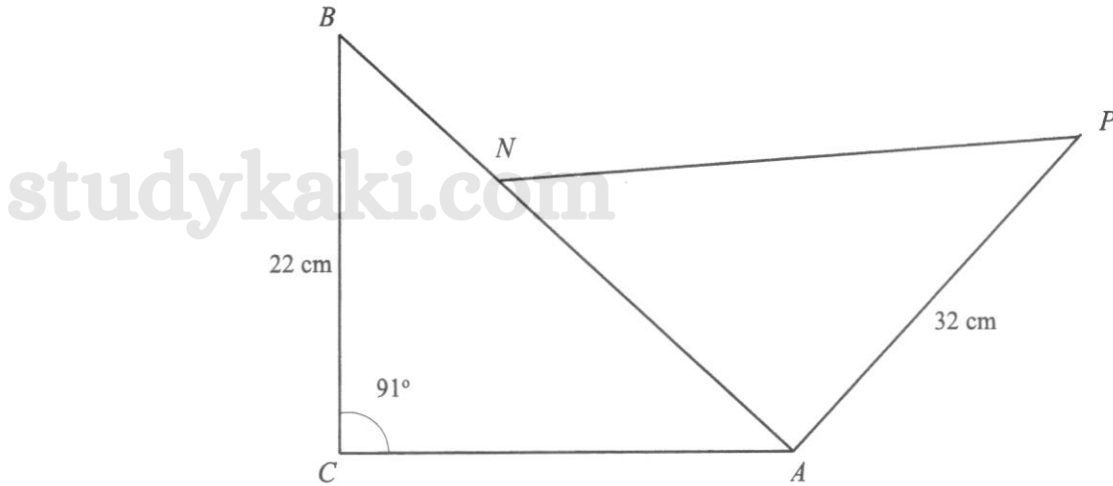

Given that $BC = 22$ cm, $AP = 32$ cm and angle $ACB = 91^\circ$, calculate

(a) the length of BN ,

studykaki.com

studykaki.com

Answer cm [3]

(b) angle APN .

studykaki.com

Answer Angle $APN =$ [2]

20 The mean of ten different numbers is 11.8.

(a) Write down a number which will generate a mean of 12, when added to these ten numbers.

studykaki.com

Answer..... [1]

(b) Each value within the ten numbers is adjusted as follows:

If the number is less than the mean, the number is decreased by 2,
if the number is greater than the mean, the number is increased by 2 and
if the number is equal to the mean, it remains unchanged.

Explain clearly how these adjustments would affect the standard deviation.

studykaki.com

Answer

.....

.....

studykaki.com

..... [2]

studykaki.com

- 21 A tour agency sells cruise packages to Vietnam, Maldives and Taiwan at \$1299, \$1398 and \$2538 respectively. The table below shows the number of customers who have signed up for the respective cruise packages via the tour agency from January to June and from July to December.

	First Period	Second Period
	From January to June	From July to December
Vietnam	27	24
Maldives	23	29
Taiwan	19	22

The number of people who signed up for cruise packages to Vietnam, Maldives and Taiwan can be

represented by the matrix $\mathbf{P} = \begin{pmatrix} 27 & 24 \\ 23 & 29 \\ 19 & 22 \end{pmatrix}$.

- (a) The elements of matrix \mathbf{C} , where $\mathbf{C} = \mathbf{AP}$, represents the total earnings for each period. Write down the matrix \mathbf{A} .

Answer $\mathbf{A} =$ [1]

- (b) Hence, by using matrix multiplication, determine the total earnings, \mathbf{C} by the tour agency for each of the period respectively.

Answer $\mathbf{C} =$ [2]

18

- (c) Given $\mathbf{M} = \mathbf{CR}$, where $\mathbf{R} = \begin{pmatrix} 1 \\ 1 \end{pmatrix}$, find the matrix \mathbf{M} .

studykaki.com

Answer $\mathbf{M} =$

[2]

- (d) Describe what is represented by the element(s) of \mathbf{M} .

Answer

.....

..... [1]

studykaki.com

studykaki.com

studykaki.com

- 22 P , Q and R are three points on level ground such that RPQ forms a right-angled triangle with PQ and RQ measuring 135 m and 205 m respectively. It is given that a building of height 50 m is situated at P and that the bearing of Q from P is 119° .

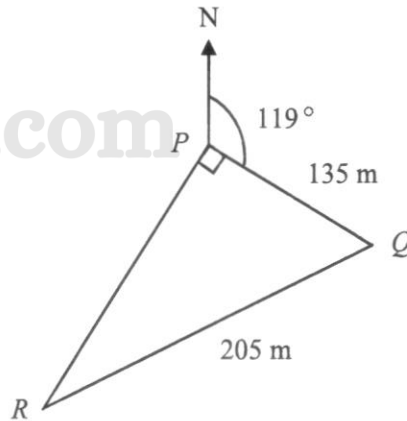

- (a) Calculate the bearing of R from Q .

Answer [2]

- (b) Calculate the largest possible angle of depression from the top of the building to any point on the path RQ .

Answer [3]

- 23 Jefferson and Victor were sent by their company to work in Washington D.C. and Beijing respectively. Jefferson rented a 696 sq ft apartment in Washington D.C. for 1800 USD while Victor rented a 60 m² apartment in Beijing for 8000 CNY. Given that the currency exchange rate for both cities is 1 USD = 7.25 CNY and that 1 m² = 10.7639 sq ft, illustrate with clear working, which apartment has a higher rental cost.

studykaki.com
Answer

studykaki.com

studykaki.com

..... studykaki.com

..... [3]

24 In the grid, $\vec{OA} = \mathbf{a}$ and $\vec{OB} = \mathbf{b}$. Q is a point on the grid.

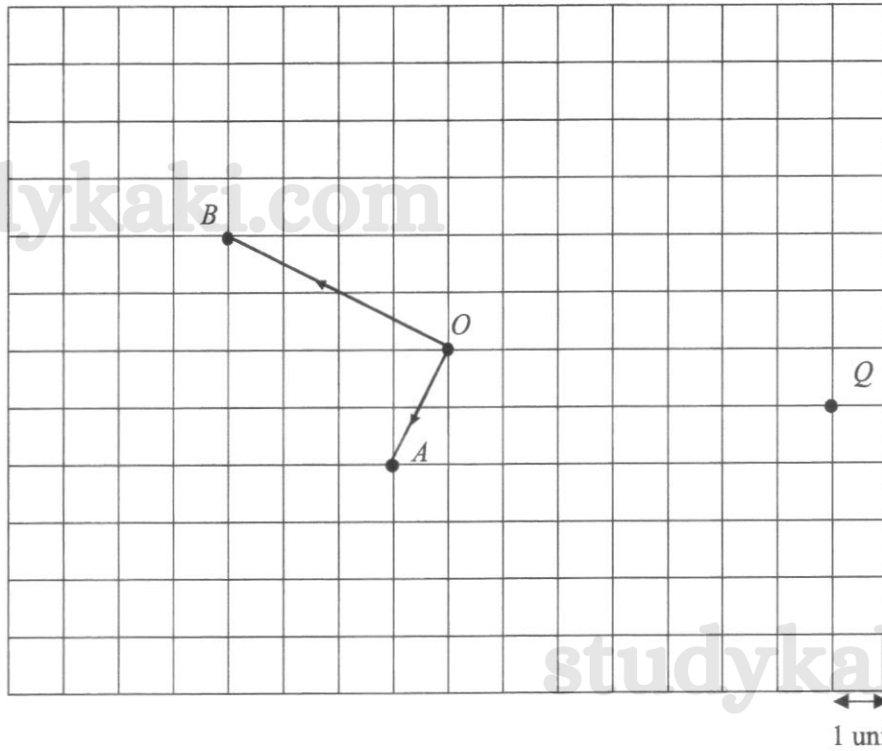

- (a) Mark and label the point P such that $\vec{OP} = -\mathbf{b} - 2\mathbf{a}$. [1]
- (b) Express \vec{OQ} in the form $m\mathbf{a} + n\mathbf{b}$, where m, n are real numbers.

studykaki.com

Answer $\vec{OQ} = \dots\dots\dots$ [1]

- (c) Given that $\vec{OC} = \begin{pmatrix} 6 \\ x \end{pmatrix}$ and \vec{OC} is parallel to \vec{AB} , find the value of x .

studykaki.com

Answer $x = \dots\dots\dots$ [2]

- 25 Edwin deposited $\$P$ each into Bank A and Bank B . Bank A offered a simple interest of 4% per annum while Bank B offered an interest rate of 2% per half-year, compounded every six months. The difference in the amount Edwin received from both banks after a period of 7 years is $\$513$. Find P , correct your answer to the nearest hundred.

studykaki.com

studykaki.com

studykaki.com

studykaki.com

Answer [4]

26 $X, Y,$ and Z are three points on a horizontal sea level map as shown below.
 X is due North of Y and Z is due east of Y .
 Ship A is on a bearing of 070° from X and on a bearing of 350° from Z .
 It is given that 1 cm represents 2 km on the sea level.

(a) Label the position of Ship A and write down the actual distance AX .

studykaki.com

Answer $AX = \dots\dots\dots$ km [2]

(b) A boat, B stationed along path XZ is equidistant from Y and Z . Label the position of B . [2]

(c) Showing your constructions clearly, draw a circle with centre O , on the map such that the lines XY, YZ and XZ are tangents to the circle. Hence write down the radius of the circle on the map.

Answer $\dots\dots\dots$ cm [2]

studykaki.com

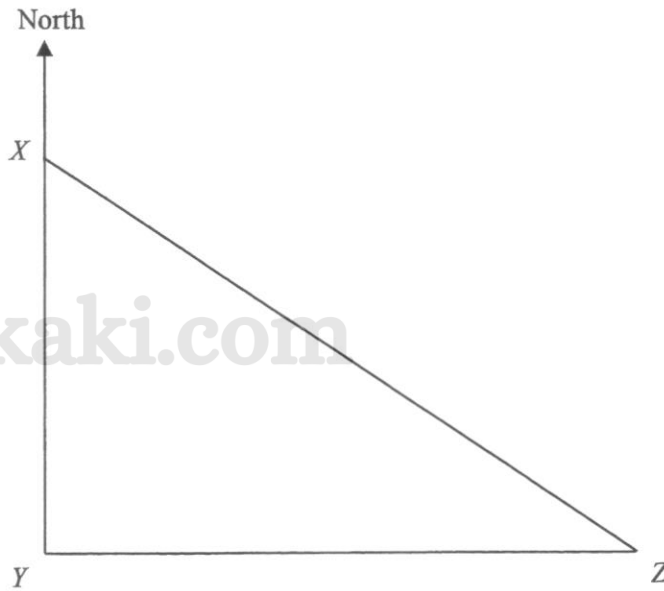

studykaki.com

studykaki.com

CANDIDATE
NAME

CLASS

INDEX
NUMBER

--	--	--	--

Anglo-Chinese School (Independent)

studykaki.com

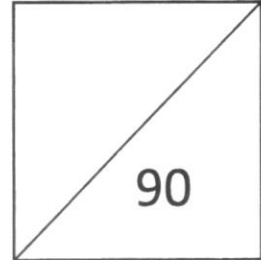

PRELIMINARY EXAMINATION 2024 YEAR FOUR EXPRESS MATHEMATICS PAPER 2

studykaki.com

4052/02

Wednesday

7 August 2024

2 hours 15 minutes

Candidates answer on the Question Paper.

READ THESE INSTRUCTIONS FIRST

Write your index number, name and class in the spaces on top of this page.
Write in dark blue or black pen.
You may use an HB pencil for any diagrams or graphs.
Do not use staples, paper clips, highlighters, glue or correction fluid.

Answer **all** questions.

The number of marks is given in brackets [] at the end of each question or part question.

If working is needed for any question it must be shown with the answer.

Omission of essential working will result in loss of marks.

The total of the marks for this paper is 90.

The use of an approved scientific calculator is expected, where appropriate.

If the degree of accuracy is not specified in the question, and if the answer is not exact, give the answer to three significant figures. Give answers in degrees to one decimal place.

For π , use either your calculator value or 3.142.

Mathematical Formulae*Compound Interest*

$$\text{Total amount} = P \left(1 + \frac{r}{100} \right)^n$$

studykaki.com

Mensuration

$$\text{Curved surface area of a cone} = \pi r l$$

$$\text{Surface area of a sphere} = 4 \pi r^2$$

$$\text{Volume of a cone} = \frac{1}{3} \pi r^2 h$$

$$\text{Volume of a sphere} = \frac{4}{3} \pi r^3$$

$$\text{Area of a triangle} = \frac{1}{2} ab \sin C$$

studykaki.com

$$\text{Arc length} = r\theta, \text{ where } \theta \text{ is in radians}$$

$$\text{Sector area} = \frac{1}{2} r^2 \theta, \text{ where } \theta \text{ is in radians}$$

Trigonometry

$$\frac{a}{\sin A} = \frac{b}{\sin B} = \frac{c}{\sin C}$$

$$a^2 = b^2 + c^2 - 2bc \cos A$$

Statistics

$$\text{Mean} = \frac{\sum fx}{\sum f}$$

$$\text{Standard deviation} = \sqrt{\frac{\sum fx^2}{\sum f} - \left(\frac{\sum fx}{\sum f} \right)^2}$$

studykaki.com

3

Answer **all** the questions.

- 1 (a) Solve the equation $2(x-5) = 3x-1$.

studykaki.com

Answer $x = \dots\dots\dots$ [2]

- (b) Solve the inequality $7-4y > 3(y+2)$.

studykaki.com
Answer $\dots\dots\dots$ [2]

- (c) Given that $\frac{1}{p} - \frac{1}{2q} = \frac{1}{3r}$,

- (i) find p when $q = -1$ and $r = 2$,

studykaki.com

Answer $p = \dots\dots\dots$ [2]

- (ii) rearrange the formula to make q the subject.

studykaki.com

Answer $q = \dots\dots\dots$ [3]

4

(d) Solve the equation $\frac{5}{x+2} - \frac{3x}{2x-1} = 3$.

Give your solutions correct to 2 decimal places.

studykaki.com

studykaki.com

Answer $x = \dots\dots\dots$ or $\dots\dots\dots$ [5]

- 2 (a) A manufacturing company produces electronic components for various devices. They are analyzing the production data for the past 3 months, which includes quantities of components produced and the corresponding costs.

The data is presented in the table below:

Month	Quantity Produced (in units)	Cost per unit (in dollars)
May	5.8×10^5	0.0211
June	4.3×10^6	0.0183
July	7.6×10^5	0.0203

- (i) Express the total quantity produced from May to July in standard form correct to 3 significant figures.

studykaki.com

Answer $\dots\dots\dots$ [1]

- (ii) Calculate the average cost per unit for these 3 months.
Express your answer in cents.

studykaki.com

Answer cents [2]

- (iii) Given that the percentage increase in the quantity produced from July to August is 11.8%, calculate the quantity produced in August.
Leave your answer in standard form correct to 3 significant figures.

Answer units [2]

- (b) The company wants to build a prototype of a particular electronic component they are manufacturing.
The radius of the actual electronic component is 3.8×10^{-5} m.
In a scale drawing, the radius of the prototype of the electronic component is 1.9 cm.

- (i) Find the scale used for the drawing.
Give your answer in the form $n : 1$.

studykaki.com

Answer : 1 [2]

- (ii) Given that the prototype has a total surface area of 1.81×10^{-8} m², find, in cm², the actual total surface area of the electronic component. Give your answer in standard form.

studykaki.com

Answer cm² [2]

- 3 In Diagram I below, $ABCDE$ is a regular pentagon, centre O . $OA = OB = 4$ cm.

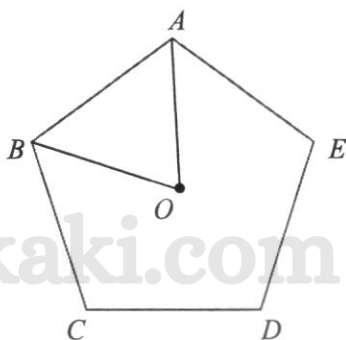

Diagram I

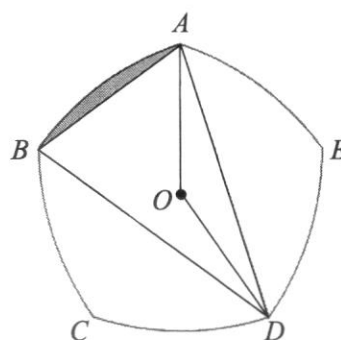

Diagram II

- (a) State the value of angle AOB .

Answer Angle $AOB = \dots\dots\dots^\circ$ [1]

- (b) Calculate the area of the pentagon $ABCDE$.

Answer $\dots\dots\dots$ cm² [2]

- (c) Diagram II shows a design for a new badge.

The vertices of the regular pentagon $ABCDE$ are joined by circular arcs whose centres are the opposite vertices.

For example, the arc AB has centre D and radius AD .

- (i) Find angle ABD .
Give reasons for each step of your working.

studykaki.com

Answer Angle $ABD = \dots\dots\dots^\circ$ [2]

(ii) Show that the length of BD is approximately 7.61 cm.

Answer

studykaki.com

[2]

(iii) Calculate the area of the shaded segment in Diagram II.

studykaki.com

studykaki.com

Answer cm² [3]

(iv) Calculate the area of the face $ABCDE$ of the badge.

studykaki.com

Answer cm² [2]

8

- 4 Here are the first four terms of a sequence.

$$2 \quad \frac{5}{3} \quad \frac{10}{5} \quad \frac{17}{7}$$

- (a) Find the fifth term of the sequence.

Answer [1]

- (b) T_n is the n th term of the sequence.

Find an expression, in terms of n , for T_n .

Answer $T_n =$ [2]

- (c) Find the value of $T_{25} - T_{24}$.

Answer $T_{25} - T_{24} =$ [1]

- 5 The diagram shows a solid ornament in the shape of a cylinder with an upright cone cut out at one end and a hemisphere attached to the other end.

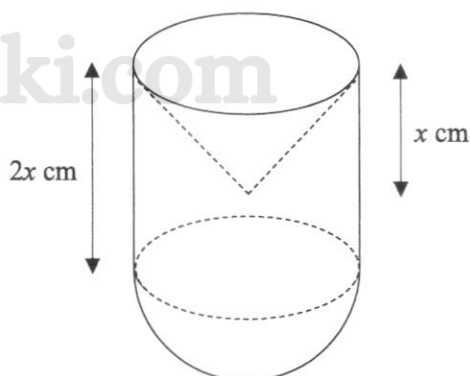

The vertical heights of the cone and cylinder are x cm and $2x$ cm respectively.

- (a) Find the ratio of the volume of the cone to that of the cylinder, expressing your answer as a fraction in the simplest form.

Answer [1]

- (b) If the volume of the cylinder is 345 cm^3 and its height is 8 cm, calculate
- (i) the radius of the cylinder,

studykaki.com

Answer cm [2]

- (ii) the curved surface area of the cone,

studykaki.com

Answer cm^2 [3]

- (iii) the quantity of paint needed to paint the exterior of the ornament with a 0.2 mm thick coat of paint.

studykaki.com

studykaki.com

Answer cm^3 [3]

- 6 In the diagram, $OABC$ is a parallelogram and D is the midpoint of BC . BE and OC produced intersect at point F . It is given that $BE : BF = 1 : 3$, $OC : OF = 1 : 2$, $\vec{OA} = \mathbf{a}$ and $\vec{OC} = \mathbf{c}$.

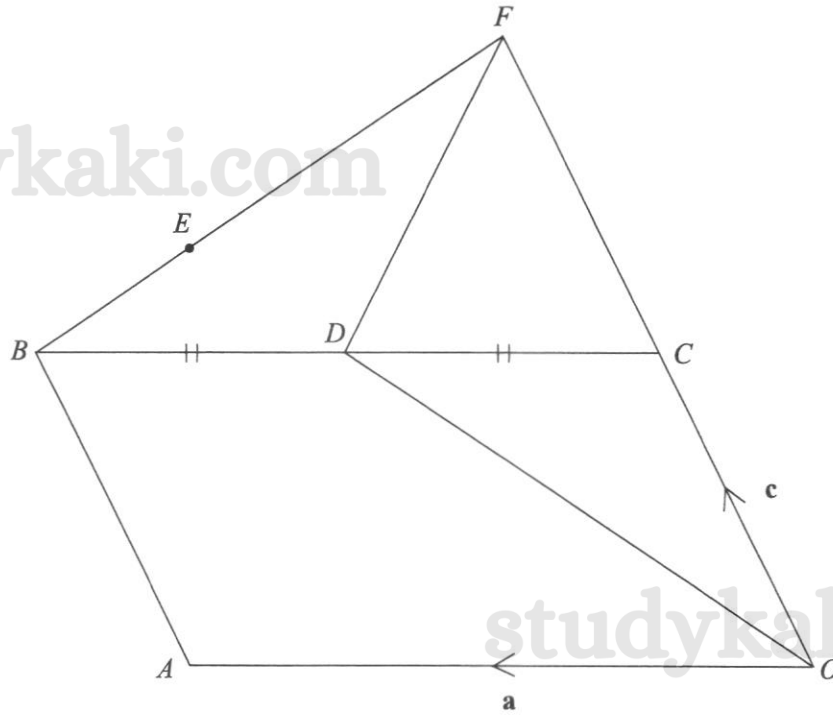

- (a) Express and simplify the following vectors in terms of \mathbf{a} and \mathbf{c} ,

(i) \vec{BF} ,

Answer $\vec{BF} = \dots\dots\dots$ [1]

(ii) \vec{AE} ,

Answer $\vec{AE} = \dots\dots\dots$ [2]

(iii) \overline{OD} .

Answer $\overline{OD} = \dots\dots\dots$ [1]

(b) Determine, with clear working shown, whether points O, D and E lie on a straight line.
Answer

studykaki.com

.....
.....
.....
.....[3]

studykaki.com

(c) Find the value of $\frac{\text{area of triangle } CDE}{\text{area of parallelogram } OABC}$.

studykaki.com

Answer [2]

- 7 (a) Complete the table of values for $y = 2x + \frac{1}{x^2} - 4$.

Values are given to two decimal places where appropriate.

x	-2	-1	-0.5	-0.3	0.3	0.5	1	2	3
y	-7.75	-5	-1	6.51	7.71		-1	0.25	2.1

studykaki.com

[1]

- (b) On the grid opposite, draw the graph of $y = 2x + \frac{1}{x^2} - 4$ for $-2 \leq x \leq 3$. [3]

- (c) (i) $y = b$ cuts the graph of $y = 2x + \frac{1}{x^2} - 4$ at one point for $-2 \leq x \leq 3$, state the range of values of b .

Answer [1]

- (ii) On the same grid, draw the graph of $3y - 5x = 4$ for $-2 \leq x \leq 3$. [2]

studykaki.com

- (iii) Write down the x -coordinates of the points where the graph of $3y - 5x = 4$ intersects the curve for $-2 \leq x \leq 3$.

Answer $x = \dots\dots\dots$ and $\dots\dots\dots$ [2]

- (iv) These values of x are solutions of the equation $x^3 + Ax^2 + B = 0$.
Find the value of A and the value of B .

studykaki.com

studykaki.com

Answer $A = \dots\dots\dots$

$B = \dots\dots\dots$

[3]

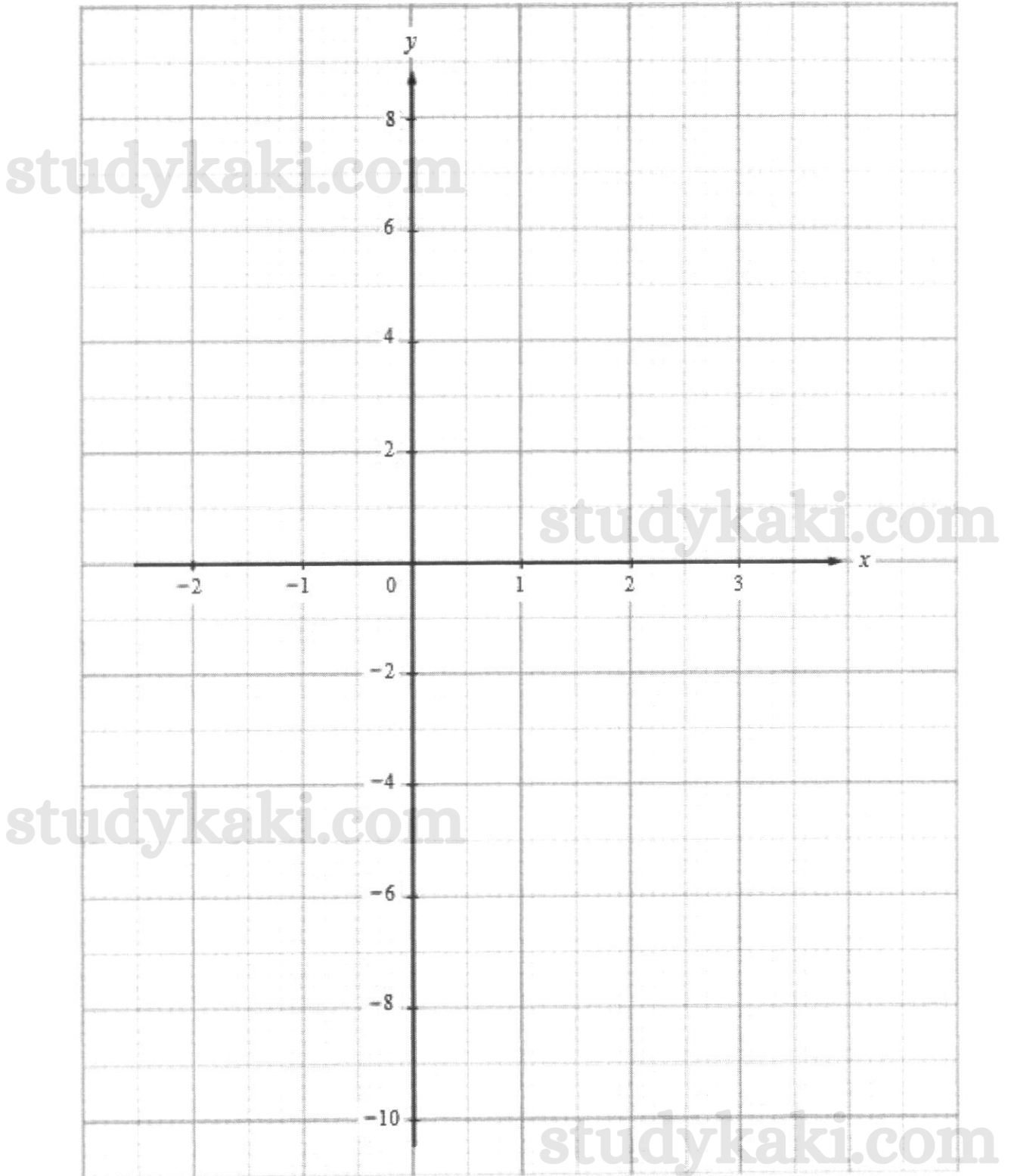

- 8 (a) The box-and-whisker plots show the distribution of the masses (in grams) of eggs sold in Shop A and Shop B.

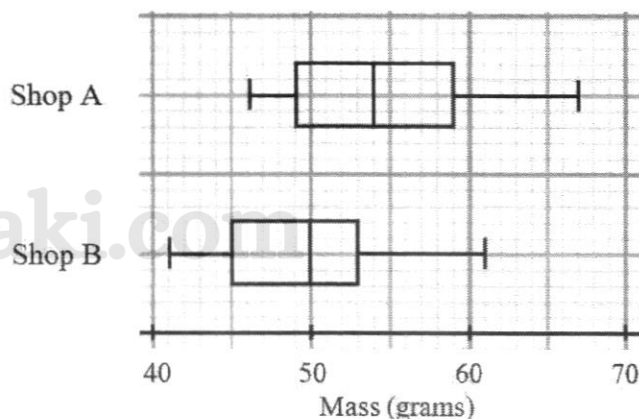

- (i) There are 25 eggs with masses of more than 59 g sold in Shop A.

Find the total number of eggs sold in Shop A.

studykaki.com

Answer eggs [1]

- (ii) Make a comment comparing the averages and a comment comparing the distribution of the masses of the eggs sold in Shop A and Shop B.

Use figures to support your answers.

studykaki.com

1.

2.

 [3]

studykaki.com

15

- (b) In a sample of 80 eggs, 4 are cracked.
- (i) One egg is selected from the sample at random.
Find the probability that the egg is cracked.

studykaki.com

Answer [1]

- (ii) Two eggs are selected from the sample at random.
Find the probability that both eggs are cracked.

studykaki.com

Answer [2]

- (iii) Three eggs are selected from the sample at random.
Find the probability that at least one egg is cracked.

studykaki.com

studykaki.com

Answer [2]

- 9 Emily is considering signing up for a new credit card and has shortlisted three options: Card A, Card B and Card C. Each card offers distinct benefits, rewards, and imposes different annual fees.

The table below presents the essential features of each card:

Card Features	Credit Card		
	Card A	Card B	Card C
Annual Fee ¹ (in SGD) payable at the end of 12 months	\$110	\$90	Waived off for the first year; \$250 for 2nd year onwards
Cashback ² Rate per month	1.5% of expenditure	1.3% of expenditure	1.2% of expenditure
Sign-up Bonus (in SGD) to be used to offset the first bill payment	\$50	\$60	\$70
Number of Free Airport Lounge Access Passes per year	2	4	Unlimited

¹ Cardholder does not enjoy cashback on the annual fee.

² Cashback amount is the amount of money received by the cardholder based on his/her expenditure. The cashback amount will be credited to the card account and used to offset the credit card bill for that month.

- (a) Calculate the net rewards (which consist of cashback and sign-up bonus) for each credit card for an expenditure of SGD 2000 within the first month of card usage.

studykaki.com

studykaki.com

Answer Card A: \$.....

Card B: \$.....

Card C: \$.....

[3]

- (b) Emily's monthly card expenditure is SGD 2000.

Assuming Emily has signed up for credit card A, by considering only the annual fee and the net rewards, calculate the total amount she has to pay for her credit card bill after the first year of usage.

studykaki.com

studykaki.com

Answer \$..... [2]

- (c) Emily enjoys travelling. As such, travel perks are important to her.

The following table provides a summary of Emily's monthly expenditure and travel needs.

Additional information

- Monthly Card Expenditure (excluding annual fee and purchases made for airport lounge access passes): SGD 2000
- Airport Lounge Access Passes³ required per year: 5

³ Credit card must be presented at the Airport Lounge. Any Airport Lounge access pass bought, costing \$50 each, must be charged to the same credit card. Cardholder will not be able to enjoy cashback on the amount spent on Airport Lounge access passes.

Determine which credit card might be the best choice for Emily if she signs up for the card and uses it for two consecutive years.

Justify any decisions you make and show your calculations clearly.

Continuation of working space for question 9(c).

studykaki.com

studykaki.com

studykaki.com

studykaki.com

.....
.....
.....[7]

WORKED SOLUTIONS FOR ACS(I) MATHEMATICS PRELIM 2024 P1

1(a)	$\frac{AC}{BC} = \frac{2}{5}$																																																	
1(b)	$\frac{24}{2} \times 5 = 60 \text{ cm}$																																																	
2(a)	$\sin x = 0.66913$ $x = 42$ or $x = 180 - 42 = 138$ where x is obtuse																																																	
2(b)	$\cos y = -\cos 121$ $y = 180 - 121 = 59$																																																	
3(a)	<table border="1" style="margin-left: auto; margin-right: auto;"> <thead> <tr> <th></th> <th>1</th> <th>2</th> <th>3</th> <th>4</th> <th>5</th> <th>6</th> </tr> </thead> <tbody> <tr> <th>1</th> <td>0</td> <td>1</td> <td>2</td> <td>3</td> <td>4</td> <td>5</td> </tr> <tr> <th>2</th> <td>1</td> <td>0</td> <td>1</td> <td>2</td> <td>3</td> <td>4</td> </tr> <tr> <th>3</th> <td>2</td> <td>1</td> <td>0</td> <td>1</td> <td>2</td> <td>3</td> </tr> <tr> <th>4</th> <td>3</td> <td>2</td> <td>1</td> <td>0</td> <td>1</td> <td>2</td> </tr> <tr> <th>5</th> <td>4</td> <td>3</td> <td>2</td> <td>1</td> <td>0</td> <td>1</td> </tr> <tr> <th>6</th> <td>5</td> <td>4</td> <td>3</td> <td>2</td> <td>1</td> <td>0</td> </tr> </tbody> </table>		1	2	3	4	5	6	1	0	1	2	3	4	5	2	1	0	1	2	3	4	3	2	1	0	1	2	3	4	3	2	1	0	1	2	5	4	3	2	1	0	1	6	5	4	3	2	1	0
	1	2	3	4	5	6																																												
1	0	1	2	3	4	5																																												
2	1	0	1	2	3	4																																												
3	2	1	0	1	2	3																																												
4	3	2	1	0	1	2																																												
5	4	3	2	1	0	1																																												
6	5	4	3	2	1	0																																												
3(b)	$\frac{2}{36} = \frac{1}{18}$																																																	
4	<p>Price with profit of 45%: $\\$24 \times \frac{145}{100} = \\34.80</p> <p>Listed Price before 20% discount: $\\$34.8 \times \frac{100}{80} = \\43.50</p>																																																	
5(a)	<p>$B(-2, 0)$</p> <p>$y = a(x+2)(x-6)$</p> <p>Substitute (1, 15) into eq to find a: $a = -1$</p> <p>Find maximum coordinate: when $x = 2, y = 16$. Equation: $y = -(x-2)^2 + 16$</p>																																																	

5(b)	$4 = -(x - 2)^2 + 16$ $x = 2 + \sqrt{12} \text{ or } 2 + 2\sqrt{3} \text{ (positive value)}$
6	<p>It is not clear as to whether the height or the area of the phones should be used to determine the data usage. It is also not clear if the values in the vertical axis start from 0 which can lead to misinterpretation.</p>
7	$\left(\frac{1}{2}x^2\right)^3 + 4\sqrt[3]{x^5}$ $= 2^{-3}x^6 + 2^2x^{\frac{5}{3}}$ $= \frac{1}{32}x^{\frac{13}{3}}$
8(a)	$13824 = 2^9 \times 3^3$
8(b)	<p>Since $13824 = 2^9 \times 3^3 = (2^3 \times 3)^3$. It can be written as a cube of a number.</p>
8(c)	$\frac{1}{8a} \times 2^9 \times 3^3 \rightarrow a = 3$

studykaki.com

studykaki.com

9

Statement A

$$\frac{\text{Area } \triangle ABF}{\text{Area } \triangle AFE}$$

$$= \frac{\text{Area } \triangle ABF}{\text{Area } ABCD} \times \frac{\text{Area } ABCD}{\text{Area } \triangle AFE}$$

$$= \frac{1}{9} \times \frac{6}{1} = \frac{2}{3}$$

Statement B is incorrect

$$\frac{\text{Area of } \triangle DFC}{\text{Area of } ABCD}$$

$$= \frac{0.5 \times FC \times AB}{BC \times AB}$$

$$= \frac{0.5 \times 7}{9}$$

$$= \frac{7}{18}$$

Statement C

$$\text{Area of } \triangle ABF \text{ \& } \triangle DCF$$

$$= \frac{1}{2} \times AD \times AB$$

$$\text{Area of } \triangle AFE \text{ \& } \triangle DEF$$

$$= \frac{1}{2} \times BC \times AB$$

Since $AD = BC$, their sums are equal.

10

Let the number of Volleyballs be x .

$$\frac{\frac{11}{7}x + 126}{x - 233} = \frac{14}{3}$$

$$\frac{33}{7}x + 378 = 14x - 3262$$

$$\frac{65}{7}x = 3640$$

$$x = 392$$

11	<p><u>Method 1</u></p> $(5n+2)^2 - (5n-2)^2$ $= 25n^2 + 20n + 4 - (25n^2 - 20n + 4)$ $= 40n$ $= 8(5n)$ <p><u>Method 2</u></p> $(5n+2)^2 - (5n-2)^2$ $= (5n+2+5n-2)(5n+2-5n+2)$ $= 40n$ $= 8(5n)$ <p>Hence, $(5n+2)^2 - (5n-2)^2$ is a multiple of 8.</p>
12(a)	$45b - 18ab - 2a^2 + 5a$ $= 9b(5 - 2a) + a(5 - 2a)$ $= (a + 9b)(5 - 2a)$ <p>or</p> $= (-9b - a)(2a - 5)$ <p>or</p> $= -(a + 9b)(2a - 5)$
12(b)	$2p^2 - \frac{2}{3}p - \frac{1}{6}$ $= \frac{1}{6}(12p^2 - 2p - 1)$ $= \frac{1}{6}(6p+1)(2p-1)$ <p>or $(2p-1)(p+\frac{1}{6})$</p> <p>or $(2p+\frac{1}{3})(p-\frac{1}{2})$</p> <p>or $2(p+\frac{1}{6})(p-\frac{1}{2})$</p>

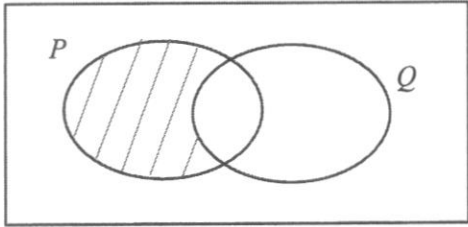
13	$\frac{x^2 - 9y^2}{3x^2 + 7xy - 6y^2}$ $= \frac{(x-3y)(x+3y)}{(3x-2y)(x+3y)}$ $= \frac{x-3y}{3x-2y}$
14a)	<p>Points (0, 3), (1, 5) and (3, 9) lie on $y = 2x + 3$</p> $P \cap Q = \{(0, 3), (1, 5), (3, 9)\}$
14(b)	<p>ξ</p>  <p>The diagram shows a rectangular universal set ξ containing two overlapping ovals, P and Q. The region of oval P that does not overlap with Q is shaded with diagonal lines. The region of oval Q that does not overlap with P is unshaded. The intersection of P and Q is also unshaded.</p>
15	$\sqrt{(k-9)^2 + (7-k)^2} = \sqrt{20}$ $k^2 - 18k + 81 + 49 - 14k + k^2 = 20$ $2k^2 - 32k + 110 = 0$ $k^2 - 16k + 55 = 0$ $(k-5)(k-11) = 0$ $k = 5 \quad k = 11$ <p>(rej.)</p>

16	<p>In 1 hour, Mr Tan travelled $\frac{1}{4}$ of the distance between Town A and B while Mr Lim travelled $\frac{1}{8}$ of that distance</p> $\frac{1}{4} + \frac{1}{8} = \frac{3}{8}$ <p>$\frac{1}{8}$ distance ----- $\frac{1}{3}$ hour $\frac{8}{8}$ distance ----- $\frac{8}{3}$ hour</p> <p>11 am + $2\frac{2}{3}$ hour = 1.40pm</p>
17	<p>Remaining house to be painted = $1 - \frac{5}{6} = \frac{1}{6}$</p> <p>Sam can paint $\frac{1}{6}$ house in 3 days, he will paint the entire house in 18 days.</p> <p>Rate at which Sam & Wilson take to paint the house = $\frac{1 \text{ house}}{6 \text{ days}}$</p> <p>Rate at which Wilson take to paint he house = $\frac{1 \text{ house}}{6 \text{ days}} - \frac{1 \text{ house}}{18 \text{ days}} = \frac{1 \text{ house}}{9 \text{ days}}$</p> <p>Time taken for Wilson to paint the house on his own = $1 \div \frac{1}{9} = 9 \text{ days}$</p>
18(a)	60 th Percentile → read off from 144 → 76 minutes
18(b)	<p>Upper Quartile → read off from 180 → 84 Lower Quartile → read off from 60 → 54</p> <p>Interquartile Range = 84 - 54 = 30 min</p>
18(c)	<p>10% - 24 customers Read off from 216 → 100 minutes</p>

18(d)	$P(\text{less than or equal to } 60 \text{ min}) \times P(\text{more than } 100 \text{ min})$ $+ P(\text{more than } 100 \text{ min}) \times P(\text{less than or equal to } 60 \text{ min})$ $= \frac{76}{240} \times \frac{24}{239} + \frac{24}{240} \times \frac{76}{239}$ $= \frac{76}{1195}$
19(a)	$(AB)^2 = (22)^2 + (32)^2 - 2(22)(32)\cos(91)$ $AB = 39.148 \text{ cm}$ $BN = 39.1 - 22 = 17.1 \text{ cm (3 s.f.)}$
19(b)	$\frac{\sin \angle APN}{22} = \frac{\sin 91}{39.148}$ $\angle APN = 34.186^\circ$ $\angle APN = 34.2^\circ$
20(a)	$(12 \times 11) - (11.8 \times 10) = 14$
20(b)	<p>These adjustments make smaller numbers even smaller and larger numbers even larger. This widens the overall spread of the numbers. Since standard deviation measures how spread out the numbers are from the mean, the standard deviation will increase.</p>
21(a)	$A = \begin{pmatrix} 1299 & 1398 & 2538 \end{pmatrix}$
21(b)	$C = \begin{pmatrix} 1299 & 1398 & 2538 \\ 27 & 24 \\ 23 & 29 \\ 19 & 22 \end{pmatrix}$ $= \begin{pmatrix} 115449 & 127554 \end{pmatrix}$
21(c)	$M = \begin{pmatrix} 115449 & 127554 \\ 1 \end{pmatrix}$ $= (115449 + 127554)$ $= (243003)$
21(d)	<p>M represent the total earnings in both periods</p>

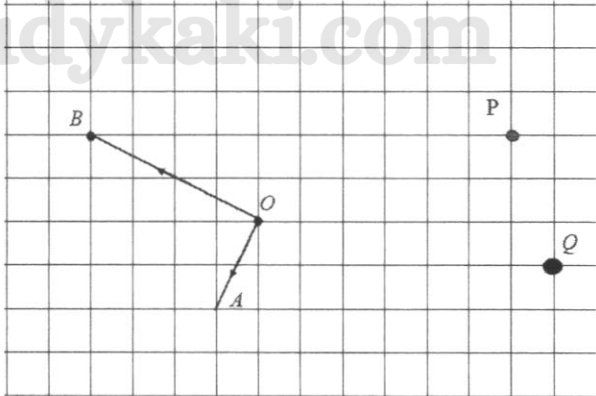
22(a)	$\cos \angle PQR = \frac{135}{205}$ $\angle PQR = 48.81164 = 48.8^\circ$ <p>Bearing of R from Q</p> $= 360 - (180 - 119) - 48.8$ $= 250.2^\circ$
22(b)	<p>Shortest distance from P to RQ</p> $= 135 \sin 48.81164$ $= 101.594 \text{ m}$ <p>Angle of depression</p> $= \tan^{-1} \left(\frac{50}{101.594} \right)$ $= 26.2^\circ$
23	<p>Jefferson's apartment</p> $= 201.82 \text{ CNY/ m}^2 \text{ or } 27.84 \text{ USD/ m}^2$ $= 18.75 \text{ CNY/ sqft or } 2.586 \text{ USD/ sqft}$ <p>Victor's apartment</p> $= 133.33 \text{ CNY/ m}^2 \text{ or } 18.391 \text{ USD/ m}^2$ $= 12.387 \text{ CNY/ sqft or } 1.708 \text{ USD/ sqft}$ <p>Hence, Jefferson's apartment has a higher rental cost.</p>
24(a)	

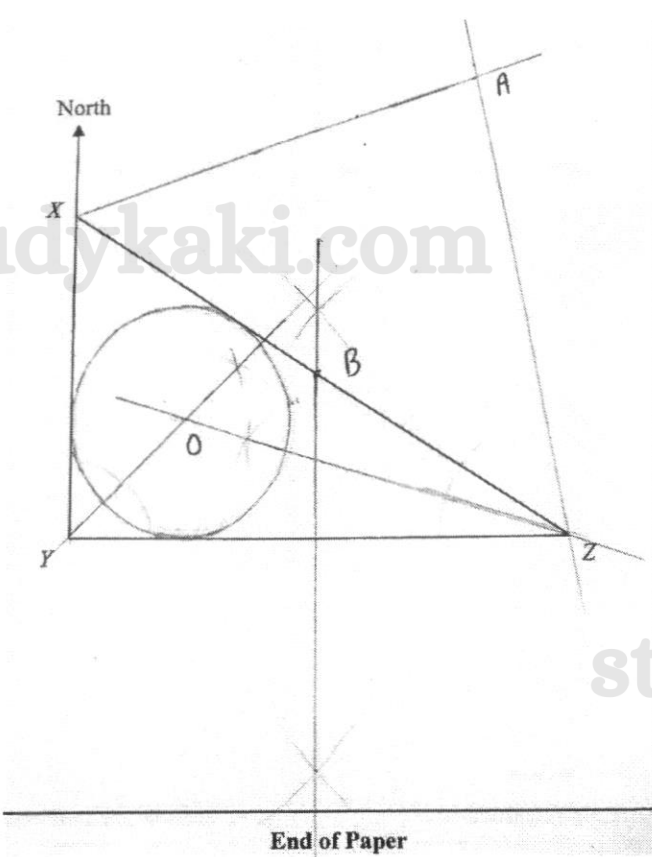
24(b)	$\overline{OQ} = -\frac{3}{2}b - a$
24(c)	$\overline{OC} = k\overline{AB}$ $\begin{pmatrix} 6 \\ x \end{pmatrix} = k \begin{pmatrix} -3 \\ 4 \end{pmatrix}$ $k = -2$ $x = -2(4) = -8$
25	<p>Bank A: $I_A = \frac{P \times 4 \times 7}{100} = 0.28P$</p> <p>Bank B:</p> $A = P \left(1 + \frac{2}{100} \right)^{14} = 1.319478763P$ $I_B = 0.319478763P$ <p>Given $0.319478763P - 0.28P = 513$</p> $0.03947876P = 513$ $\therefore P = 12994.33 = 13000 \text{ (nearest hundred)}$
26	<p>(a) $AX = 14.6 \text{ km } (\pm 0.2 \text{ km})$</p>  <p>(d) Radius of circle = 2 cm ($\pm 0.2 \text{ cm}$)</p>

WORKED SOLUTIONS FOR ACS(I) 2024 MATHEMATICS PRELIM P2

1a	$2(x-5) = 3x-1$ $2x-10 = 3x-1$ $x = -9$
b	$7-4y > 3(y+2)$ $7-4y > 3y+6$ $1 > 7y$ $y < \frac{1}{7}$
ci	$\frac{1}{p} - \frac{1}{2q} = \frac{1}{3r}$ $\frac{1}{p} - \frac{1}{2(-1)} = \frac{1}{3(2)}$ $\frac{1}{p} = \frac{1}{6} - \frac{1}{2}$ $\frac{1}{p} = -\frac{1}{3}$ $\therefore p = -3$
cii	$\frac{1}{p} - \frac{1}{2q} = \frac{1}{3r}$ $\frac{1}{2q} = \frac{1}{p} - \frac{1}{3r}$ $\frac{1}{2q} = \frac{3r-p}{3pr}$ $q = \frac{3pr}{2(3r-p)}$
d	$\frac{5}{x+2} - \frac{3x}{2x-1} = 3$ $5(2x-1) - 3x(x+2) = 3(x+2)(2x-1)$ $10x-5-3x^2-6x = 3(2x^2+3x-2)$ $4x-5-3x^2 = 6x^2+9x-6$ $9x^2+5x-1=0$ $x = \frac{-5 \pm \sqrt{5^2 - 4(9)(-1)}}{2(9)}$ $= \frac{-5 \pm \sqrt{61}}{18}$ $x = -0.71 \text{ (2 dp)} \text{ or } 0.16 \text{ (2 dp)}$
2ai	$5.8 \times 10^5 + 4.3 \times 10^6 + 7.6 \times 10^5$ $= 5.64 \times 10^6$
a ii	$\frac{5.8 \times 10^5 \times 0.0211 + 4.3 \times 10^6 \times 0.0183 + 7.6 \times 10^5 \times 0.0203}{5.64 \times 10^6}$ $= \$0.0189$ $= 1.89 \text{ cents (2 dp)}$
a iii	$7.6 \times 10^5 \times \frac{111.8}{100} = 849680 = 8.50 \times 10^5 \text{ (3 s.f.)}$

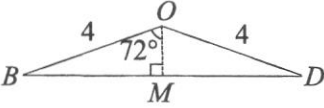
bi	$3.8 \times 10^{-5} \text{ m} = 0.0038 \text{ cm}$ 0.0038 cm is represented by 1.9 cm . 1 cm is represented by $\frac{1.9}{0.0038} \text{ cm} = 500 \text{ cm}$ \therefore The scale used is $500 : 1$.
bii	$1.81 \times 10^{-8} \text{ m}^2 = 1.81 \times 10^{-4} \text{ cm}^2$ 500 cm of the prototype represents 1 cm of the actual electronic component. $500 \times 500 \text{ cm}^2 = 2.5 \times 10^5 \text{ cm}^2$ of the prototype represents 1 cm^2 of the actual. $\therefore 1.81 \times 10^{-4} \text{ cm}^2$ of the prototype represents $\frac{1.81 \times 10^{-4}}{2.5 \times 10^5} = 7.24 \times 10^{-10} \text{ cm}^2$ of the actual.
3a	$\angle AOB = 360^\circ \div 5$ $= 72^\circ$ (\angle s at a point)
b	Area of the pentagon $ABCDE = 5 \times \frac{1}{2}(4)(4) \sin 72^\circ$ $= 38.042 \text{ cm}^2$ (5 sf) $= 38.0 \text{ cm}^2$ (3 sf)
ci	$\angle ADB = 72^\circ \div 2$ (\angle at centre = $2 \angle$ at circumference) $= 36^\circ$ $\angle ABD = \frac{180^\circ - 36^\circ}{2}$ (Base \angle s of isosceles triangle) $= 72^\circ$
cii	 $BD = 2 \times BM$ $= 2 \times 4 \sin 72^\circ$ $= 7.61 \text{ cm}$ (3 sf) (Shown) <u>OR</u> $\frac{4}{\sin \angle ODB} = \frac{BD}{\sin \angle BOD}$ $\frac{4}{\sin 18^\circ} = \frac{BD}{\sin 144^\circ}$ $\therefore BD = 7.61 \text{ cm}$ (3 sf) (Shown) <u>OR</u> $\angle BOD = (360^\circ - 72^\circ) \div 2$ (\angle s at a point) $= 144^\circ$ $BD^2 = 4^2 + 4^2 - 2(4)(4) \cos 144^\circ$ $= \sqrt{32 - 32 \cos 144^\circ}$ $BD \approx 7.60845$ $= 7.61 \text{ cm}$ (3 sf) (Shown)

ciii	<p>Area of shaded segment</p> <p>= Area of sector DAB - Area of $\triangle DAB$</p> $= \frac{36^\circ}{360^\circ} \times \pi \times (7.60845)^2 - \frac{1}{2} \times (7.60845)^2 \times \sin 36^\circ$ $= 18.186 - 17.013$ $= 1.1732 \text{ (3 sf)}$
civ	<p>Area of the badge</p> <p>= Area of pentagon + Area of 5 segments</p> $= 38.042 \text{ cm}^2 + 5(1.1732) \text{ cm}^2$ $= 43.9 \text{ cm}^2 \text{ (3 sf)}$
4a	$T_5 = \frac{26}{9}$
b	$T_n = \frac{n^2 + 1}{2n - 1}$
c	$T_{25} - T_{24} = \frac{25^2 + 1}{2(25) - 1} - \frac{24^2 + 1}{2(24) - 1}$ $= \frac{626}{49} - \frac{577}{47}$ $= \frac{1149}{2303}$
5a	$\frac{\text{Vol of Cone}}{\text{Vol of Cylinder}} = \frac{\frac{1}{3} \pi r^2 x}{\pi r^2 (2x)} = \frac{1}{6}$
bi	Radius of cylinder = $\sqrt{\frac{345}{\pi(8)}} \approx 3.7050 = 3.71 \text{ cm (3 sf)}$
bii	<p>Slant height of Cone = $\sqrt{\left(\sqrt{\frac{345}{\pi(8)}}\right)^2 + 4^2}$</p> ≈ 5.4523 <p>Curved surface area of Cone = $\pi(3.7050)(5.4523)$</p> ≈ 63.463 $= 63.5 \text{ cm}^2 \text{ (3 sf)}$
biii	<p>Volume of paint</p> $= \left[63.463 + 2\pi(3.7050)(8) + \frac{1}{2} \times 4\pi(3.7050)^2 \right] \times \frac{0.2}{10}$ $= 6.72 \text{ cm}^3 \text{ (3 sf)}$
6ai	$\overline{BF} = -\mathbf{a} + \mathbf{c}$
aii	$\overline{AE} = \mathbf{c} + \frac{1}{3}(\mathbf{c} - \mathbf{a})$ $= \frac{1}{3}(4\mathbf{c} - \mathbf{a})$
aiii	$\overline{OD} = \frac{1}{2}\mathbf{a} + \mathbf{c}$

b

$$\overrightarrow{OE} = \overrightarrow{OA} + \overrightarrow{AE}$$

$$= \mathbf{a} + \frac{1}{3}(4\mathbf{c} - \mathbf{a})$$

$$= \frac{2}{3}\mathbf{a} + \frac{4}{3}\mathbf{c}$$

$$= \frac{4}{3}\left(\frac{1}{2}\mathbf{a} + \mathbf{c}\right)$$

$$\overrightarrow{OE} = \frac{4}{3}\overrightarrow{OD} \Rightarrow \overrightarrow{OE} \parallel \overrightarrow{OD}$$

\overrightarrow{OE} and \overrightarrow{OD} share a common point O and therefore points O , D and E lie on the same straight line.

OR

$$\overrightarrow{DE} = \overrightarrow{DB} + \overrightarrow{BE}$$

$$= \frac{1}{2}\mathbf{a} + \frac{1}{3}\overrightarrow{BF}$$

$$= \frac{1}{2}\mathbf{a} + \frac{1}{3}(-\mathbf{a} + \mathbf{c})$$

$$= \frac{1}{6}\mathbf{a} + \frac{1}{3}\mathbf{c}$$

$$= \frac{1}{3}\left(\frac{1}{2}\mathbf{a} + \mathbf{c}\right)$$

$$\overrightarrow{DE} = \frac{1}{3}\overrightarrow{OD} \Rightarrow \overrightarrow{DE} \parallel \overrightarrow{OD}$$

\overrightarrow{DE} and \overrightarrow{OD} share a common point D and therefore points O , D and E lie on the same straight line.

c

area of triangle CDE

area of parallelogram $OABC$

$$= \frac{\text{Area of } \triangle CDE}{\text{Area of } \triangle CDO} \times \frac{\text{Area of } \triangle CDO}{\text{Area of parallelogram } OABC}$$

$$= \frac{1}{3} \times \frac{1}{4}$$

$$= \frac{1}{12}$$

7a 1

b

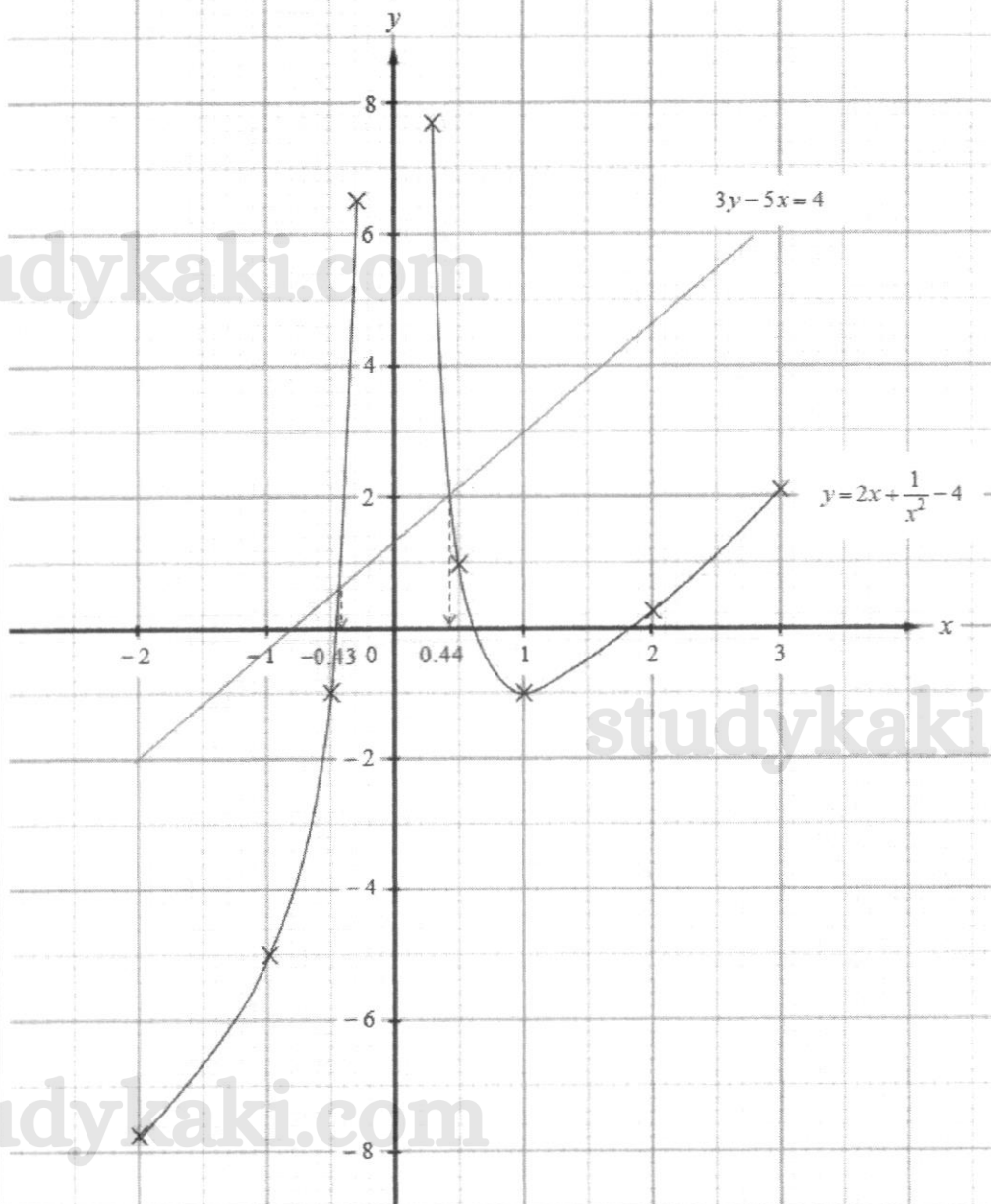
ci $-7.75 \leq b < -1$ [Accept also $b < -1$]

cii On graph.

ciii $x = -0.43, 0.44$

civ

$$y = 2x + \frac{1}{x^2} - 4$$

$$3y - 5x = 4$$

Sub. (1) into (2).

$$3\left(2x + \frac{1}{x^2} - 4\right) - 5x = 4$$

$$6x + \frac{3}{x^2} - 12 - 5x = 4$$

$$x^3 - 16x^2 + 3 = 0$$

$$\therefore A = -16, B = 3$$

8ai	$Q_3 = 59 \text{ g}$ Total number of eggs $= 25 \times 4$ $= 100$
aii	1. $Q_{2A} = 54 \text{ g}; Q_{2B} = 50 \text{ g}$ Masses of eggs in shop A are heavier due to its higher median value. 2. $IQR_{2A} = 59 \text{ g} - 49 \text{ g} = 10 \text{ g}; IQR_{2B} = 53 \text{ g} - 45 \text{ g} = 8 \text{ g}$ Masses of eggs in shop B are more consistent due to its lower IQR.
bi	Probability that the egg is cracked $= \frac{4}{80}$ $= \frac{1}{20}$
bii	Probability that both eggs are cracked $= \frac{4}{80} \times \frac{3}{79}$ $= \frac{3}{1580}$
biii	Probability that at least one egg is cracked $= 1 - \frac{76}{80} \times \frac{75}{79} \times \frac{74}{78}$ $= \frac{593}{4108}$

9a	<p>Net rewards for Card A = Expenditure after Cashback + Sign-up Bonus $= \frac{1.5}{100} \times 2000 + 50$ $= \\$80$</p> <p>Net rewards for Card B = Expenditure after Cashback + Sign-up Bonus $= \frac{1.3}{100} \times 2000 + 60$ $= \\$86$</p> <p>Net rewards for Card C = Expenditure after Cashback + Sign-up Bonus $= \frac{1.2}{100} \times 2000 + 70$ $= \\$94$</p>
b	<p>Credit card bill for Card A = Expenditure after Cashback – Sign-up Bonus + Annual Fee $= \left[\left(1 - \frac{1.5}{100} \right) \times 2000 \times 12 \right] - 50 + 110$ $= \\$23700$</p>
c	<p>Credit card bill after 2 years for Card A = Expenditure after Cashback + Airport Lounge Passes – Sign-up Bonus + Annual Fee $= \left[\left(1 - \frac{1.5}{100} \right) \times (2000 \times 12 \times 2) \right] + 6 \times 50 - 50 + (110 \times 2)$ $= \\$47750$</p> <p>Credit card bill after 2 years for Card B = Expenditure after Cashback + Airport Lounge Passes – Sign-up Bonus + Annual Fee $= \left[\left(1 - \frac{1.3}{100} \right) \times (2000 \times 12 \times 2) \right] + 2 \times 50 - 60 + (90 \times 2)$ $= \\$47596$</p> <p>Credit card bill after 2 years for Card C = Expenditure after Cashback – Sign-up Bonus + Annual Fee $= \left[\left(1 - \frac{1.2}{100} \right) \times (2000 \times 12 \times 2) \right] - 70 + 250$ $= \\$47604$</p> <p>Credit card B has the least bill amount. Therefore, Card B is the best choice.</p>