

NAME:	NO:	CLASS:
-------	-----	--------

**ADMIRALTY SECONDARY SCHOOL**



<b>STRUCTURED CLASS TEST 2019</b>
-----------------------------------

SUBJECT : Science  
 LEVEL/STREAM : Secondary 1 Express  
 DATE : 17 May 2019  
 TIME : 0755h – 0835h  
 DURATION : 40 minutes

**Instructions to candidates:**

Write your name, index number and class on the cover page.  
 Write in dark blue or black pen.  
 Do not use staples, paper clips, highlighters, glue or correction fluid.

**Section A:** Multiple Choice Questions [5 marks]  
 Answer all questions in the boxes provided in the question paper.

**Section B:** Short Answer Questions [15 marks]  
 Answer all questions. Write your answers in the spaces provided in the question paper.

**Section C:** Structured Questions [10 marks]  
 Answer all questions. Write your answers in the spaces provided in the question paper.

Candidates are reminded that all quantitative answers should include appropriate units.  
 The use of an approved scientific calculator is expected, where appropriate.  
 The number of marks is given in brackets [ ] at the end of each question or part question.

For Examiner's Use	
<b>Section A</b>	/ 5
<b>Section B</b>	/ 15
<b>Section C</b>	/ 10
<b>Total</b>	/ 30

**DO NOT TURN OVER THIS PAPER UNTIL YOU ARE TOLD TO DO SO.**

---

This question paper consists of **9** printed pages including this cover page.



4 Which of the following separation techniques is most suitable to obtain pure water from a mixture of salt and water?

- A chromatography
- B distillation
- C evaporation
- D filtration

5 Which of the following statements on biodiversity is correct?

- A Biodiversity is the existence of different human races on earth.
- B Biodiversity is the existence of different kinds of animals on earth.
- C Biodiversity is the existence of different kinds of living things on earth.
- D Biodiversity is the existence of different kinds of plants on earth.

**Section B**

Answer all questions.

1 Fig. 1.1 shows a cotton shirt.



**Fig. 1.1**

(a) Suggest the physical property that makes cotton suitable as a material for shirt in Singapore.

..... [1]

(b) The shirt can also be made of nylon (a type of plastic). Suggest a physical property that is common to both cotton and nylon that is important in a shirt. Explain why this property is important.

.....  
.....  
..... [2]

- 2 Fig. 2.1 shows an experiment in which magnesium was heated in air.

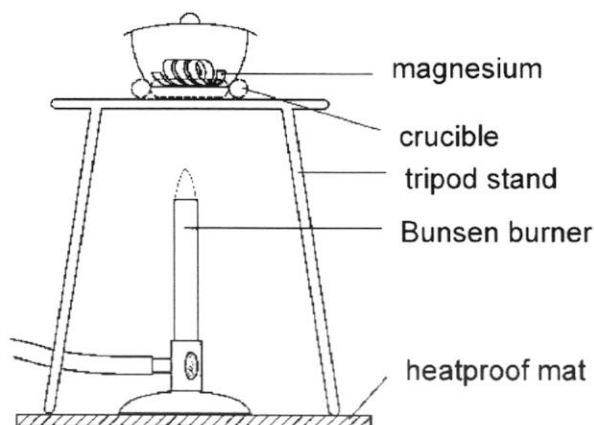

Fig. 2.1

The experimental report is given below.

1. Magnesium is a grey metal. A piece of magnesium was placed in a crucible and weighed.
2. The crucible was heated and the magnesium burnt with a very bright flame.
3. A white solid consisting of magnesium oxide ( $\text{MgO}$ ) and a small amount of magnesium nitride ( $\text{Mg}_3\text{N}_2$ ) was formed.
4. The white solid and crucible were weighed.

(a) From the report, identify:

(i) an element: ..... [1]

(ii) two compounds: ..... [2]

(b) State one evidence from the report to indicate that new products have been formed through this experiment.

.....  
 ..... [1]

- 3 Fig. 3.1 shows an experimental set-up of distillation.

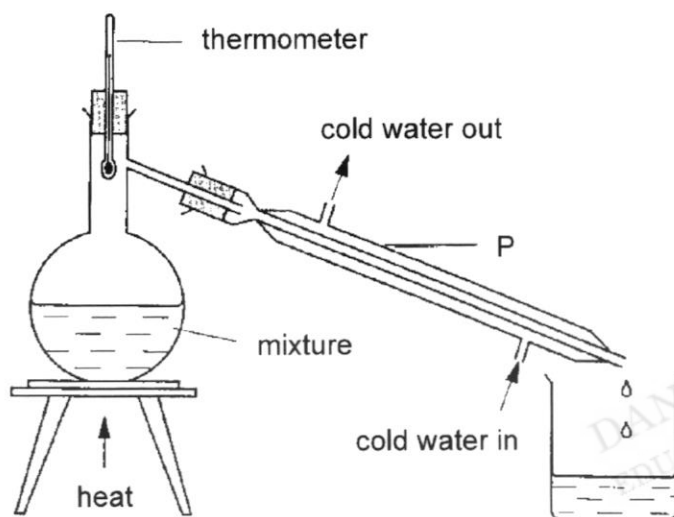

Fig. 3.1

- (a) Name the apparatus labelled P. Explain its function in distillation.

.....  
 ..... [2]

- (b) Table 3.2 shows the melting and boiling points of substances G and H.

substance	melting point / °C	boiling point / °C
G	15	68
H	18	68

Table 3.2

Zack mentions that a mixture of substances G and H can be separated using distillation. Do you agree or disagree with Zack? Explain your answer.

.....  
 .....  
 ..... [2]



## Section C

Answer all questions.

- 5 (a) The bar graph below shows the amount of three solutes P, Q and R that can dissolve in  $20 \text{ cm}^3$  of three different solvents, X, Y and Z, at room temperature.

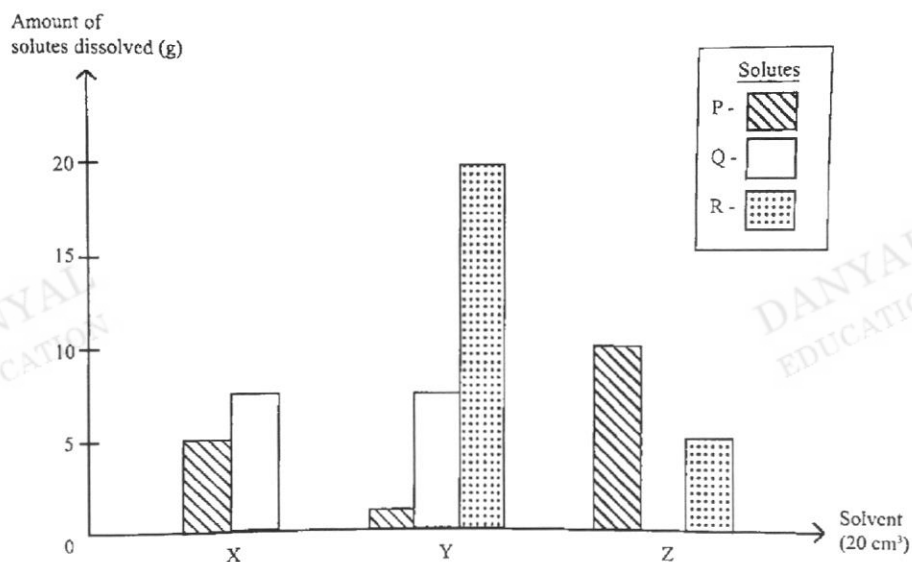

- (i) Define what is a solute.

..... [1]

- (ii) Which solute, P, Q or R, is most soluble in solvent Y?

..... [1]

- (iii) Solute P and solute R are accidentally mixed together. Briefly describe how you would separate and obtain solutes P and R.

..... [3]

- 5 (a) (iv) Jason's shirt was accidentally stained with solute R.  
Which solvent is the best to remove the stain?

..... [1]

- (v) Suggest one method that Jason can do to remove the stain more quickly.

..... [1]

- (b) Copper metal is often mixed with gold when making jewellery because it is much cheaper. The amount of gold in jewellery is indicated by the number of carats. A 24-carat gold ring is pure gold with no copper.

A goldsmith claimed that a ring he has is made of 24-carat gold. This ring has a mass of 26 g and a volume of 2 cm<sup>3</sup>.

- (i) Calculate the density of this ring.

density = ..... [1]

- (ii) The density of pure gold is 19.3 g/cm<sup>3</sup>.

From your result in (b)(i), suggest whether the goldsmith's claim about his gold ring is true.

.....  
.....

..... [2]

END OF PAPER

## The Periodic Table of Elements

I		Group										III	IV	V	VI	VII	0		
												1 H hydrogen 1						2 He helium 4	
		<b>Key</b> proton (atomic) number atomic symbol name relative atomic mass										5 B boron 11	6 C carbon 12	7 N nitrogen 14	8 O oxygen 16	9 F fluorine 19	10 Ne neon 20		
3 Li lithium 7	4 Be beryllium 9											13 Al aluminium 27	14 Si silicon 28	15 P phosphorus 31	16 S sulfur 32	17 Cl chlorine 35.5	18 Ar argon 40		
11 Na sodium 23	12 Mg magnesium 24	19 K potassium 39	20 Ca calcium 40	21 Sc scandium 45	22 Ti titanium 48	23 V vanadium 51	24 Cr chromium 52	25 Mn manganese 55	26 Fe iron 56	27 Co cobalt 59	28 Ni nickel 59	29 Cu copper 64	30 Zn zinc 65	31 Ga gallium 70	32 Ge germanium 73	33 As arsenic 75	34 Se selenium 79	35 Br bromine 80	36 Kr krypton 84
37 Rb rubidium 85	38 Sr strontium 88	39 Y yttrium 89	40 Zr zirconium 91	41 Nb niobium 93	42 Mo molybdenum 96	43 Tc technetium -	44 Ru ruthenium 101	45 Rh rhodium 103	46 Pd palladium 106	47 Ag silver 108	48 Cd cadmium 112	49 In indium 115	50 Sn tin 119	51 Sb antimony 122	52 Te tellurium 128	53 I iodine 127	54 Xe xenon 131		
55 Cs caesium 133	56 Ba barium 137	57 – 71 lanthanoids	72 Hf hafnium 178	73 Ta tantalum 181	74 W tungsten 184	75 Re rhenium 186	76 Os osmium 190	77 Ir iridium 192	78 Pt platinum 195	79 Au gold 197	80 Hg mercury 201	81 Tl thallium 204	82 Pb lead 207	83 Bi bismuth 209	84 Po polonium -	85 At astatine -	86 Rn radon -		
87 Fr francium -	88 Ra radium -	89 – 103 actinoids	104 Rf rutherfordium -	105 Db dubnium -	106 Sg seaborgium -	107 Bh bohrium -	108 Hs hassium -	109 Mt meitnerium -	110 Ds darmstadtium -	111 Rg roentgenium -	112 Cn copernicium -		114 Fl flerovium -		116 Lv livermorium -				

69

6

lanthanoids

57 La lanthanum 139	58 Ce cerium 140	59 Pr praseodymium 141	60 Nd neodymium 144	61 Pm promethium -	62 Sm samarium 150	63 Eu europium 152	64 Gd gadolinium 157	65 Tb terbium 159	66 Dy dysprosium 163	67 Ho holmium 165	68 Er erbium 167	69 Tm thulium 169	70 Yb ytterbium 173	71 Lu lutetium 175
89 Ac actinium -	90 Th thorium 232	91 Pa protactinium 231	92 U uranium 238	93 Np neptunium -	94 Pu plutonium -	95 Am americium -	96 Cm curium -	97 Bk berkelium -	98 Cf californium -	99 Es einsteinium -	100 Fm fermium -	101 Md mendelevium -	102 No nobelium -	103 Lr lawrencium -

actinoids

The volume of one mole of any gas is 24 dm<sup>3</sup> at room temperature and pressure (r.t.p.).

NAME: ANSWER SCHEME

NO:

CLASS: 1E/1NA(SBB)

## ADMIRALTY SECONDARY SCHOOL

## STRUCTURED CLASS TEST 2019

SUBJECT : Science  
 LEVEL/STREAM : Secondary 1 Express  
 DATE : 2019

## Section A

Answer all questions.

1	2	3	4	5
A	A	B	B	C

[5]

## Section B

Answer all questions.

Q.	Description	Mark	Remarks
1(a)	Absorbent/absorbs sweat easily  OR low density / poor conductor of heat (cos this helps in keeping wearer cool in Singapore)  REJECT: eg Flexible, opaque (applies to all shirt, not just in Singapore context)	[1]	Accept other reasonable answers within Singapore context
1(b)	Flexible, So that the person can move easily in that shirt  OR Good heat insulator so that heat is not easily transferred out from the body and the person will not feel cold	[1] [1]	Accept other reasonable answers Physical property need NOT be in Singapore context
2(a)	(i) Magnesium (ii) Magnesium oxide and magnesium nitride	[1] [1] [1]	
2(b)	Magnesium was <b>grey in colour but the product was white in colour</b>	[1]	Any 1 Accept any other reasonable

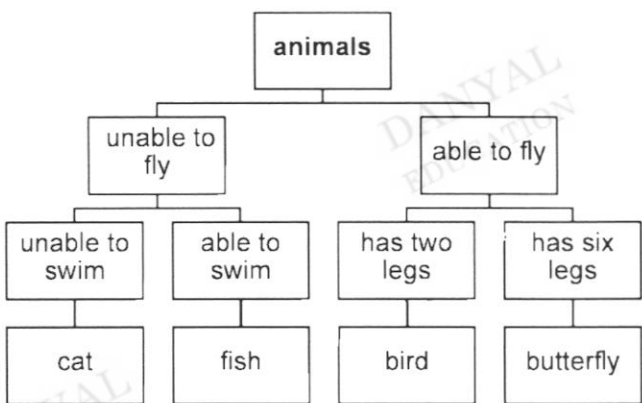
	OR Magnesium <b><u>changes colour after being heated</u></b>  OR Magnesium <b><u>burnt with a very bright flame</u></b>		answers so long evidence is from question.
3(a)	Condenser  It turns hot <b><u>vapour into liquid.</u></b>	[1]  [1]	Reject: It condenses vapour (student expected to unpack 'condense', otherwise word will just paraphrase first part of answer)
3(b)	Disagree.  Substances G and H have <b><u>the same boiling points</u></b> and will be collected together.	[1]  [1]	
4	 <pre> graph TD     animals[animals] --&gt; unable_to_fly[unable to fly]     animals --&gt; able_to_fly[able to fly]     unable_to_fly --&gt; unable_to_swim[unable to swim]     unable_to_fly --&gt; able_to_swim[able to swim]     able_to_fly --&gt; has_two_legs[has two legs]     able_to_fly --&gt; has_six_legs[has six legs]     unable_to_swim --&gt; cat[cat]     able_to_swim --&gt; fish[fish]     has_two_legs --&gt; bird[bird]     has_six_legs --&gt; butterfly[butterfly] </pre>	[4]	<p>1m – butterfly categorised under able to fly and has six legs</p> <p>1m – bird categorised under able to fly and has two legs</p> <p>1m – fish categorised under unable to fly and able to swim</p> <p>1m – cat categorised under unable to fly and unable to swim</p>

## Section C

Answer all questions.

Q.	Description	Mark	Remarks
5(a)(i)	A solute is the substance that is dissolved in a solvent.	[1]	
5(a)(ii)	Solute R	[1]	
5(a)(iii)	<b>Add solvent X</b> and <b>stir to dissolve P</b> in the mixture.	[1]	
	<b>Filter</b> to <b>obtain solute R</b>	[1]	
	<b>Evaporate</b> the filtrate to <b>obtain solute P</b>	[1]	
5(a)(iv)	Solvent Y	[1]	
5(a)(v)	Use warmer solvent Y/heat up solvent Y	[1]	
5(b)(i)	$26/2 = \underline{13 \text{ g/cm}^3}$	[1]	need to show working
5(b)(ii)	Not true	[1]	
	Since the <b>ring has different density from pure gold, it cannot be made of pure gold</b> , hence the ring is not 24-carat gold.	[1]	