



HILLGROVE SECONDARY SCHOOL
PRELIMINARY EXAMINATION 2019
SECONDARY 4 (EXPRESS) / 5 (NORMAL
ACADEMIC)

CANDIDATE
NAME

	()
--	-----

CLASS

	-	
--	---	--

CENTRE
NUMBER

S				
---	--	--	--	--

INDEX
NUMBER

--	--	--	--

MATHEMATICS

4048/01

Paper 1

22 August 2019

Candidates answer on the Question Paper.

2 hours

No Additional Materials are required.

8.00 a.m. to 10.00 a.m.

READ THESE INSTRUCTIONS FIRST

Write your class, index number and name on the work you hand in.

Write in dark blue or black pen.

You may use an HB pencil for any diagrams or graphs.

Do not use staples, paper clips, glue or correction fluid.

Answer **all** questions

If working is needed for any question it must be shown with the answer.

Omission of essential working will result in loss of marks.

The use of an approved scientific calculator is expected, where appropriate.

If the degree of accuracy is not specified in the question, and if answer is not exact, give the answer to three significant figures. Give answers in degrees to one decimal place.

For π , use either your calculator value or 3.142, unless the question requires the answer in terms of π .

At the end of the examination, fasten all your work securely together.

The number of marks is given in brackets [] at the end of each question or part question.

The total number of marks for this paper is 80.

Parent's/ Guardian's Signature:

Setter: Miss Li Ziyi

For Examiner's Use	
TOTAL	80

This document consists of 21 printed pages.

Answer all the questions.

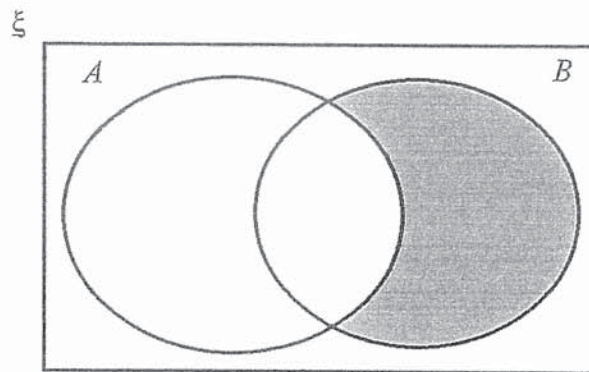
- 1 Write the following numbers in order of size, starting with the largest.

$$\frac{37}{100}, 0.3\dot{7}, 0.\dot{3}7, \left(\frac{37}{100}\right)^2$$

Answer _____, _____, _____, _____ [1]

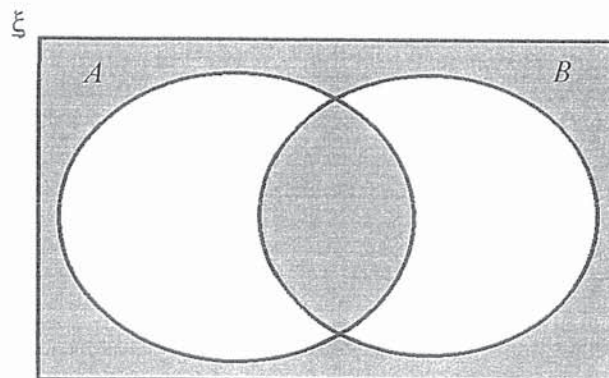
- 2 Write down the sets represented by the following shaded regions.

(a)



Answer _____ [1]

(b)



Answer _____ [1]

3 Show that $(1+5n)^2 - 6$ is a multiple of 5 for all integer values of n .

Answer

[2]

4 (a) Express $x^2 - 6x + 5$ in the form of $(x-a)^2 + b$.

Answer _____ [1]

(b) Hence, solve $x^2 - 6x + 5 = 0$.

Answer _____ or _____ [1]

5 Nithya runs a photography club.

Her club currently has 62 boys and 39 girls.

Her aim is to have at least 45 % of members to be girls.

Find the **smallest** number of girls she needs to recruit to achieve this.

Answer _____ [2]

6 A pizza is divided in the ratio of 3 : 7 : 5 for Adrian, Ben and Carl respectively. Ben then divides his share in the ratio of 9 : 7 and give it to Adrian and Carl respectively.

Carl says that both he and Adrian have the same amount of pizza now.

Do you agree with Carl? Explain your answer.

Answer

[2]

7 It is given that $y = \frac{3x+5b}{x-2c}$.

(a) Find y when $x=1$, $b=2$, $c=4$.

Answer _____ [1]

(b) Express x in terms of y , b and c .

Answer _____ [2]

8 Given that $\cos x = \frac{21}{29}$, where x is an acute angle, find the value of $\sin x + \cos(180^\circ - x) - \tan x$ without the use of calculator.

Answer _____ [3]

- 9 (a) The product of three prime numbers a , b and c is m , where m is an even number.

The smallest and the largest number out of the three prime numbers are a and c respectively.

State the value of a and explain your answer.

Answer _____

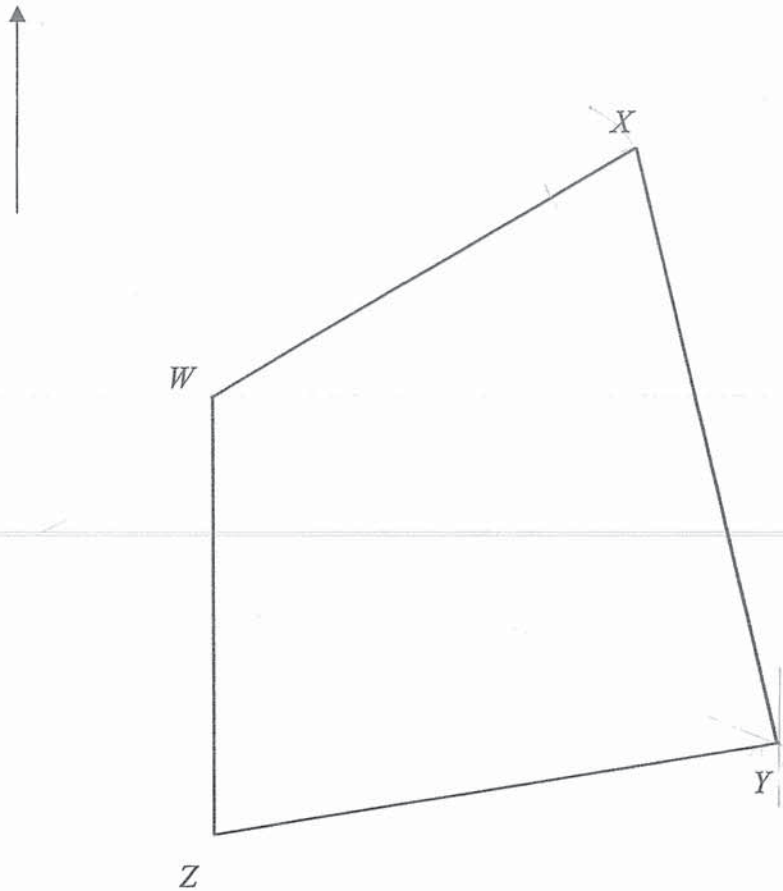
_____ [2]

- (b) Given that $b = 23$ and m is less than 670, find the largest possible value of c .

Answer _____ 13 _____ [2]

10 The diagram shows a plot of land labelled $WXYZ$.

North



- (a) Construct the bisector of angle WZY . [1]
- (b) Construct the perpendicular bisector of WZ . [1]
- (c) (i) The government is planning to build a playground that is equidistant from W and Z and WZ and YZ . Mark and label the location of the playground as P . [1]
- (ii) Hence, find the bearing of P from Y .

Answer _____ [1]

11 (a) Given that $4(x+2y) = 5x-3y$, find the ratio of $x : y$.

Answer _____ [2]

(b) Solve $\frac{27^b}{9} = 81^{b+1}$.

Answer _____ [2]

12 Winnie is drawing an n -sided regular polygon.

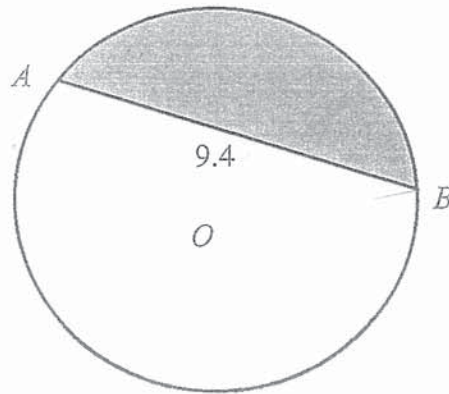
The total sum of the interior angles is h° .

Given that $h + n = 1631$, find the values of h and n .

Answer $h =$ _____

$n =$ _____ [4]

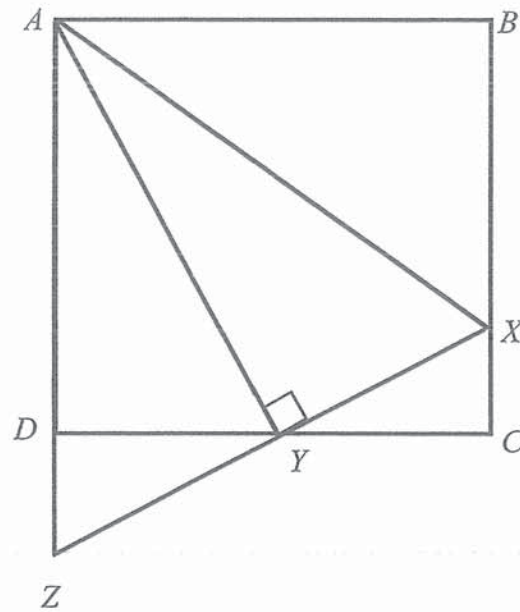
13



In the diagram, A and B are points on a circle, centre O . The radius of the circle is 5 cm and length of AB is 9.4 cm.

Find the area of the minor segment AB .

Answer _____ [4]



$ABCD$ is a square and AY is perpendicular to XZ . XYZ and ADZ are straight lines. Y is the midpoint of CD .

- (a) Show that triangle DYZ is congruent to triangle CYX .

[2]

- (ii) Show that $AZ = AX$.

[2]

- 15 Serene has two boxes of cards.
 One box contains cards that has either a circle or a square.
 The other box contain cards that are green or blue in colour.

Serene picks a card from each box at random.
 The probability that she picks a circle card is c .
 The probability that she picks a green card is g .

- (a) Complete the table for the card that Serene picks, writing each probability in terms of c and g .

Event	Probability
Circle and Green	
Square and Green	
Circle and Blue	
Square and Blue	

[2]

- (b) The probability that she picks a circle card is $\frac{2}{7}$.

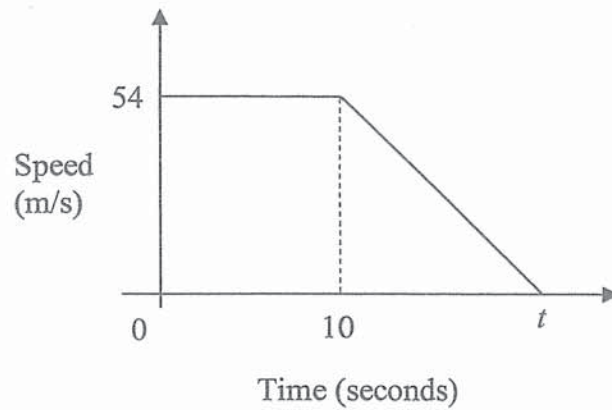
The probability that she picks a circle card and green card is $\frac{1}{5}$.

Hence, or otherwise, find the total number of green cards given that the total number of blue and green cards is 30.

Answer _____ [3]

16 The diagram shows the speed – time graph for a truck’s journey.

The distance travelled for the first t seconds is 756 m.



(a) Find t .

Answer _____ [2]

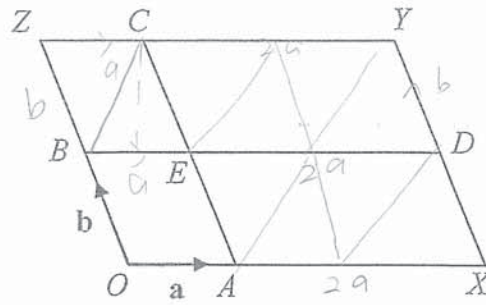
(b) Calculate the deceleration at the 15th second of the journey.

Answer _____ [2]

(c) Find the average speed in km/h.

Answer _____ [2]

17 The diagram shows a parallelogram $OXYZ$.



$\overrightarrow{OA} = \mathbf{a}$ and $\overrightarrow{OB} = \mathbf{b}$. BE and AE are lines parallel to the sides of the parallelogram.
 $\overrightarrow{OX} = 3\overrightarrow{OA}$ and $\overrightarrow{OZ} = 2\overrightarrow{OB}$.

- (a) Express \overrightarrow{EY} in terms of \mathbf{a} and \mathbf{b} , as simply as possible.

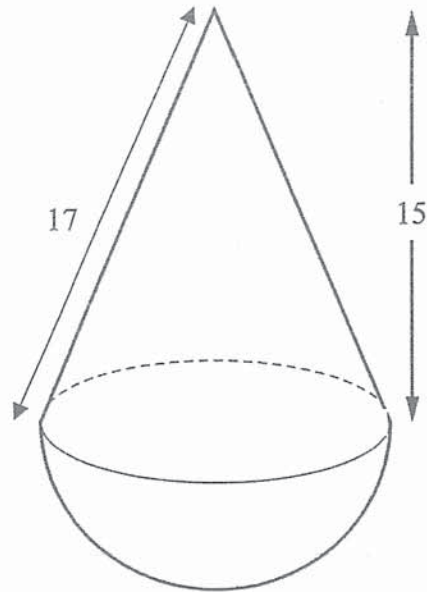
Answer _____ [2]

- (b) Write down two vectors that can be written as $\mathbf{b} - 3\mathbf{a}$.

Answer _____ and _____ [2]

- (c) Find the ratio of the area of triangle BCE to the area of parallelogram $OXYZ$.

Answer _____ [2]



The diagram shows a toy that combines a cone and a hemisphere. The slant height of the cone is 17 cm and the perpendicular height of the cone is 15 cm.

- (a) Show that the radius of the hemisphere is 8 cm.

[2]

- (b) Calculate the surface area of the toy.

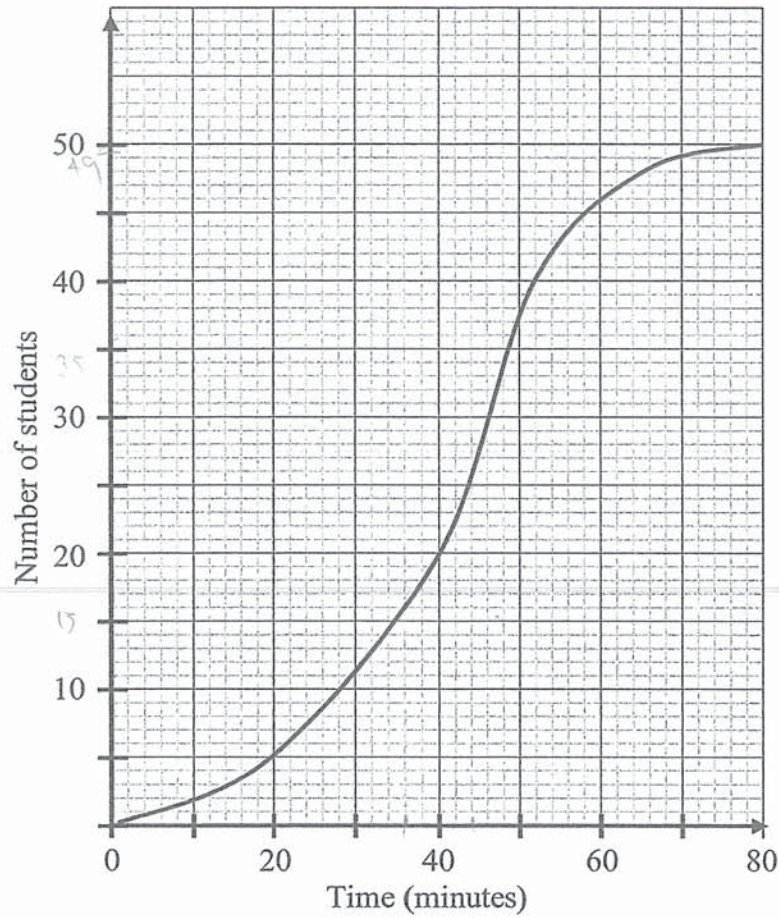
Answer _____ [3]

- (c) The company wants to make a miniature version of the toy such that the volume of the miniature toy is $\frac{1}{6}$ of the volume of the actual toy.

Calculate the radius of the miniature toy.

Answer _____ [2]

- 19 The travelling times taken by 50 students from home to school are recorded. The cumulative frequency curve below shows the distribution of their times.



(a) Use your graph to estimate

(i) the median

Answer _____ [1]

(ii) the interquartile range

Answer _____ [2]

- (b) Find the probability that two students, chosen at random, take less than 70 minutes to travel to school.

Answer _____ [2]

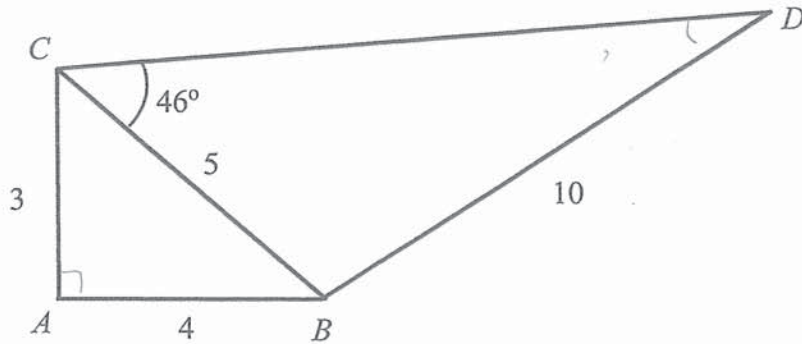
- (c) A student states that 32% of the students took at least 36 minutes to travel to school.

Comment on whether the data from the school supports this claim.

Answer _____

_____ [2]

20 The diagram shows two triangles ABC and BDC .



$AC = 3$ cm, $AB = 4$ cm, $BC = 5$ cm, $BD = 10$ cm and $\angle CBD = 113^\circ$.

(a) Show that $\angle CAB$ is a right angle.

[2]

(b) Find $\angle BDC$.

Answer _____ [2]

(c) Find the area of $ABDC$.

Answer _____ [2]

(d) A circle is drawn through the points A , B and C . State the length of the diameter of the circle. Explain your answer.

[2]



HILLGROVE SECONDARY SCHOOL
PRELIMINARY EXAMINATION 2019
SECONDARY 4 (EXPRESS) / 5 (NORMAL
ACADEMIC)

CANDIDATE NAME ()

CLASS -

CENTRE NUMBER

S				
---	--	--	--	--

INDEX NUMBER

--	--	--	--

MATHEMATICS

4048/02

Paper 2

26 August 2019

Candidates answer on the Question Paper.

2 hours 30 minutes

No Additional Materials are required.

8.00 a.m. to 10.30 a.m.

READ THESE INSTRUCTIONS FIRST

Write your class, index number and name on the work you hand in.
Write in dark blue or black pen on both sides of the paper.
You may use an HB pencil for any diagrams or graphs.
Do not use staples, paper clips, glue or correction fluid.

Answer **all** questions

If working is needed for any question it must be shown with the answer.

Omission of essential working will result in loss of marks.

The use of an approved scientific calculator is expected, where appropriate.

If the degree of accuracy is not specified in the question, and if answer is not exact, give the answer to three significant figures. Give answers in degrees to one decimal place.

For π , use either your calculator value or 3.142, unless the question requires the answer in terms of π .

At the end of the examination, fasten all your work securely together.

The number of marks is given in brackets [] at the end of each question or part question.

The total number of marks for this paper is 100.

Parent's/ Guardian's Signature:

For Examiner's Use	
TOTAL	100

Setter: Miss Li Ziyi

This document consists of 25 printed pages

Answer all the questions.

1 (a) Solve the inequality $\frac{2+3x}{5} \leq \frac{3-x}{2}$. [2]

(b) Simplify $\frac{16x^2 - y^2}{4x^2 + 9xy + 2y^2}$. [3]

- (c) Given that $x = -\frac{1}{2}$ is a solution of $(m-1)x^2 + (m-2)x = 2m-15$, find the value of m and the second possible value of x . [3]

- (d) Solve the equation $x+5 = \frac{15x-1}{3x-1}$. [3]

2 $\overline{AB} = \begin{pmatrix} 3 \\ -2 \end{pmatrix}$ and $\overline{OB} = \begin{pmatrix} 4 \\ 0 \end{pmatrix}$, where O is the origin.

(a) Find the length of AB . [1]

(b) Find the equation of line AB . [2]

(c) C is a point on x – axis such that angle ACB is a right angle. [2]

Find the tangent of angle ABC .

(d) The equation of the line m is $3y + 2x = 6$. Line m intersects the x -axis at D and y -axis at E .

(i) Show how you can tell that the line m does **not** intersect the line AB . [2]

(ii) Find \overline{ED} . [2]

(iii) What type of quadrilateral is $ABDE$? Explain your answer. [3]

3 Rashidi wants to make a closed rectangular box to contain his toys. The box has a rectangular base of sides $3x$ cm and x cm and its height is h cm.

(a) (i) The volume of the box is 90 cm^3 . [1]

Express h in terms of x .

(ii) Show that the total surface area of the box $A \text{ cm}^2$, is given by $A = \frac{240}{x} + 6x^2$. [2]

The table shows some corresponding values of x and A , correct to the nearest integer.

x	1	2	3	4	5	6	7	8
A	246	144	134	156	b	256	328	414

(a) Find the value of b . [1]

(b) Using a scale of 2 cm to represent 1 unit, draw a horizontal x -axis for $0 \leq x \leq 8$.
Using a scale of 2 cm to represent 50 units, draw a vertical A -axis for $0 \leq A \leq 500$.

On your axes, plot the points given in the table and join them with a smooth curve on the grid in page 9. [3]

(c) By drawing a tangent, find the gradient of the curve at $(2, 144)$. [2]

(d) Rashidi wants to make a box with a total surface area of 100 cm^2 without changing the volume of the box. Is it possible to do so? Explain your answer. [2]

Replace this page with graph paper.

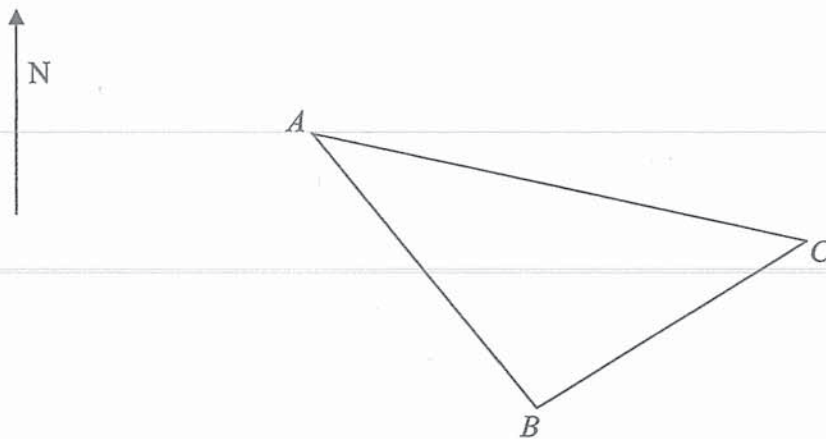
4 A , B and C represent three islands.

Both boats X and Y left from island A .

The bearings of B and C from A is 160° and 100° respectively.

Boat X sailed towards B at a speed of x km/h. Boat Y sailed towards C at a speed of $(x + 32)$ km/h.

Boat X and Y took 2 hours to reach B and C respectively.



(a) Write an expression, in terms of x , for the distance travelled by Boat X . [1]

(b) B and C are 150 km apart. [4]

Write down an equation in x to represent this information and show that it reduces to

$$x^2 + 32x - 4601 = 0.$$

(b) Solve the equation $x^2 + 32x - 4601 = 0$.

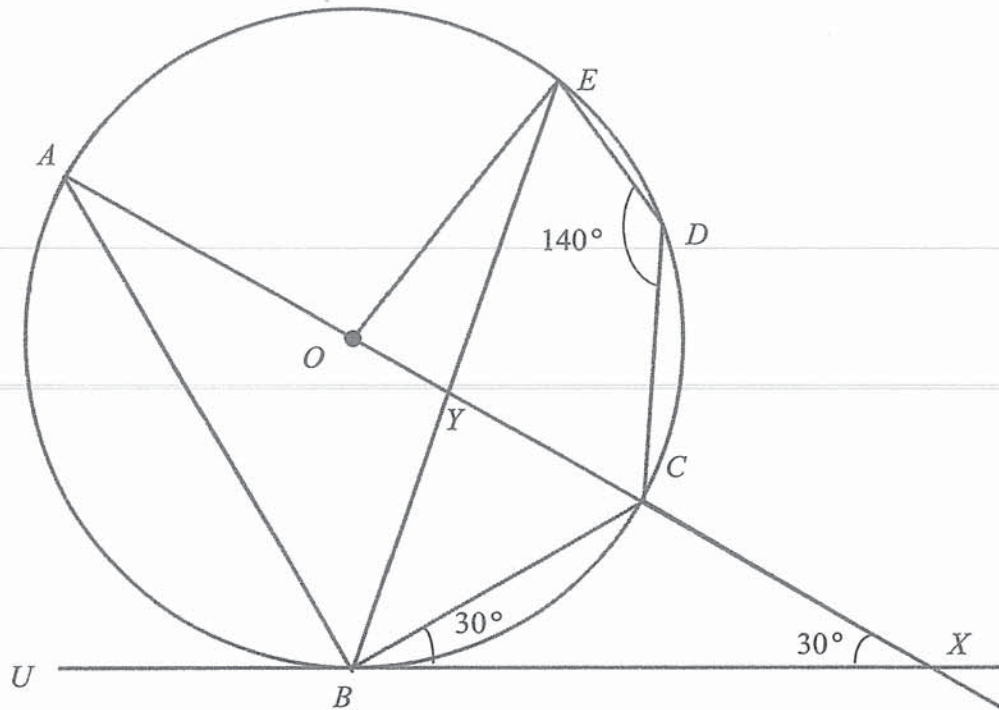
[3]

(c) Boat X returned from B to A and took 30 more minutes than the onward journey.

[2]

Find the speed of Boat X for the return journey.

- 5 O is the centre of the circle passing through A, B, C, D and E . UBX is the tangent to the circle at B . ACX is a straight line which passes through O . $\angle CBX = \angle CXB = 30^\circ$ and $\angle EDC = 140^\circ$.



(a) Stating your reasons clearly, find,

(i) $\angle BAC$,

[2]

(ii) $\angle CEB$, [1]

(iii) $\angle CBE$, [1]

(iv) $\angle OBY$. [2]

(b) T is a point such that angle ATE is 60° and on the same side as point B . [3]

State whether point T lies in the circle.

Explain your answer.

6 Angela and Ruth went on a free-and-easy trip to Sydney.

- (a) They both exchanged S\$1600 at a money changer in Singapore. The money changer used an exchange rate between Singapore dollars (S\$) and Australian dollars (A\$) of A\$ 1 = S\$0.95. [2]

Calculate the amount of Australian dollars they received.

- (b) They booked their accommodation through the Waterbnb application. [2]

Each night at the accommodation costs A\$110.25. However, there was a 10% service charge. An additional 5% daily cleaning fee was imposed **only** on the cost of the accommodation.

They booked a total of 8 nights at the accommodation.

Calculate the total cost of their accommodation in Australian dollars.

- (c) Ruth also purchased a watch in Sydney. [3]

To pay for the watch, she borrowed S\$ 2340 for 2 years at an interest of 5.6% per annum compounded half-yearly.

Calculate the amount of interest she paid for the watch.

-
- (c) Sydney has a population of 4.627 million and Darwin has a population of 132 000. [2]

Calculate how many more people live in Sydney than in Darwin, giving your answer in standard form.

7 Hillgrove organised an annual school carnival to raise funds for a children's home.

Two different classes sold three different flavours of Bubble Tea to raise funds.

The table below shows the number of Bubble Tea sold by each class and the price of the Bubble Tea.

Flavours	Class 4-10	Class 4-11	Price per cup
Milk Oolong	30	20	\$1.90
Cheese Peach	20	40	\$3.20
Brown Sugar	15	10	\$2.50

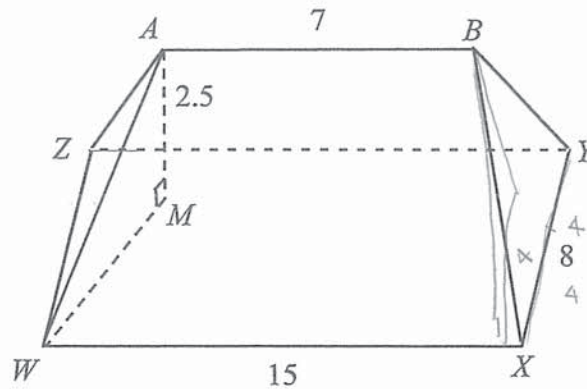
(a) Represent the number of different flavours of Bubble Tea sold by each class in a 3×2 matrix, **F**. [1]

(b) Represent the prices of Bubble Tea in a 1×3 matrix, **P**. [1]

(c) Evaluate the matrix $\mathbf{R} = \mathbf{PF}$. [2]

(d) Explain what each element in matrix \mathbf{R} means. [1]

(e) \mathbf{M} is $\begin{pmatrix} 1 \\ 1 \end{pmatrix}$. Evaluate $\mathbf{A} = \mathbf{RM}$ and explain what the element in \mathbf{A} means. [2]



The diagram represents the roof of a house. The ridge AB is horizontal and is built centrally above the rectangular plane $WXYZ$. AM is the height of the ridge above $WXYZ$. It is given that $WX = 15$ m, $XY = 8$ m, $AB = 7$ m and $AM = 2.5$ m.

(a) Show that WM is 5.657 m, correct to 4 significant figures.

[2]

(b) Find

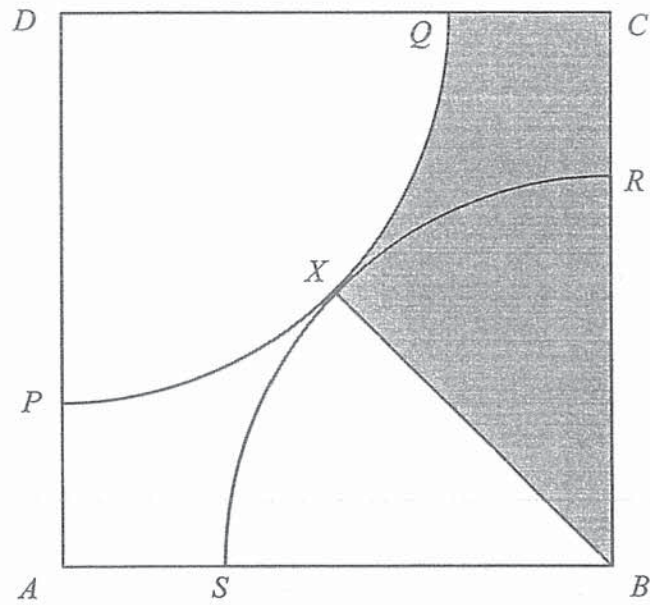
(i) angle AWM ,

[2]

(ii) AW , [2]

(iii) AX . [4]

(c) Find the **smallest** angle of elevation of A from a point along WX . [2]



$ABCD$ is a square of length 12 cm. DQP and BRS are two identical quadrants and arcs QP and RS meet at point X . DCX is a straight line.

(a) Find

(i) the perimeter of the shaded region,

[4]

(ii) the area of QRX . [Note: QRX is not a triangle]

[3]

(b) Show that triangle DAB is similar to triangle RCQ .

[3]

- 10 There was a hit and run car accident along the Pan-Island Expressway (PIE). It was raining the day before and the road was wet. PIE has a speed limit of 80 km/h. The police needed to find out who the driver was and there were some items found at the scene.

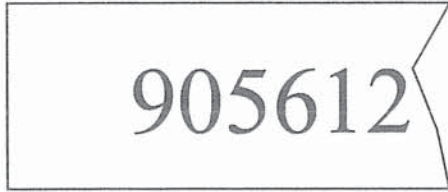


Exhibit A: slip of paper with driver's telephone number



Exhibit B: driver's shoes print -25 cm in length

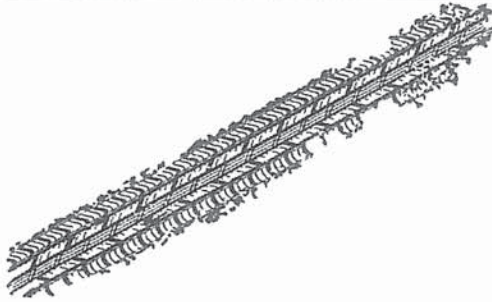
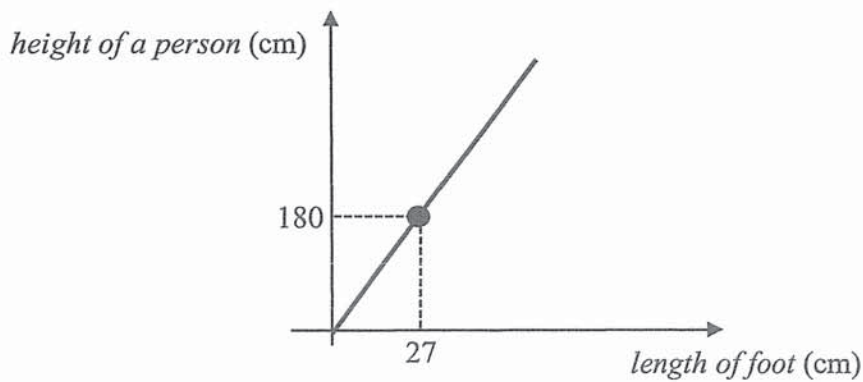
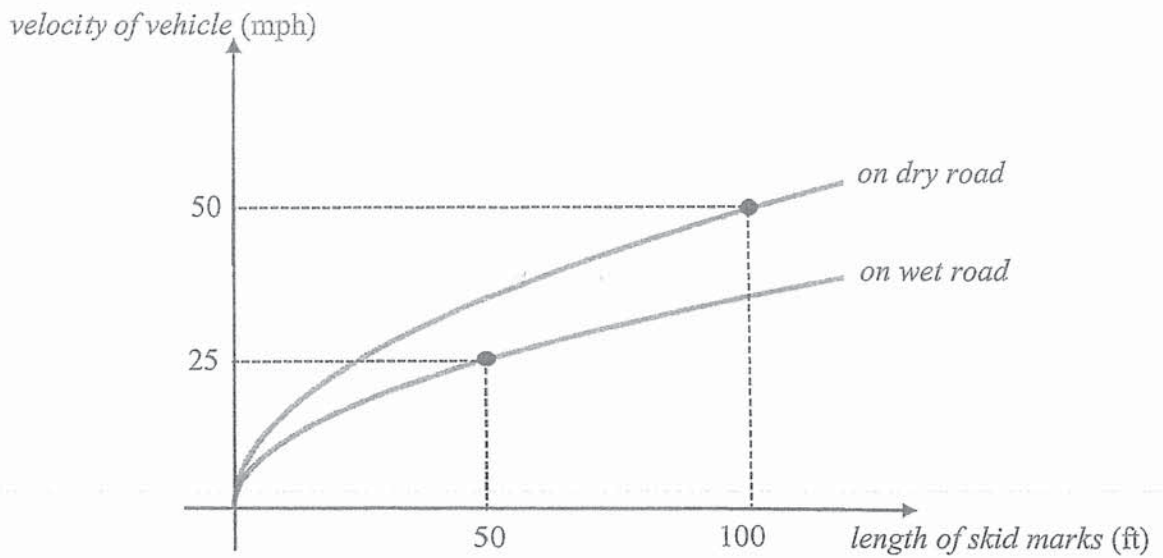


Exhibit C: driver's vehicle skid marks - 350 ft. in length
It is given that the velocity of the car is directly proportional to the square root of the length of skid marks.

The police also uses graphs below to help them to solve crimes.





Length Conversion	
1 ft	0.3048 m
1 mile	1.609 km
<i>ft</i> – feet	
<i>mph</i> – miles per hour	

Note that the graphs only give predicted estimated values.

- (a) Given that there are 8-digits in the driver's telephone number, find the total number of possible telephone numbers. [2]

The police then narrowed to three suspects with their details below.

	Daniel Lee	Jacob Yap	Samuel Wong
Height	1.78 m	1.66 m	1.82 m
Brand of vehicle they own	Kia	Toyota	Volkswagen

Speed limit	Composition Fine	
	Light Vehicle <i>(Examples: motor cars, motorcycles, light goods van, etc.)</i>	Heavy Vehicle <i>(Examples: tractors, buses, trailers, etc.)</i>
Exceeding road speed limit by 1 – 20 km/h	\$150	\$200
Exceeding road speed limit by 21 – 30 km/h	\$200	\$250
Exceeding road speed limit by 31 – 40 km/h	\$300	\$400
Exceeding 41 km/h	prosecution in court	

- (b) Find the driver who was involved in the accident and determine the appropriate fine for speeding ticket. [7]

Justify your decision with calculations.



HILLGROVE SECONDARY SCHOOL
PRELIMINARY EXAMINATION 2019
SECONDARY 4 (EXPRESS) / 5 (NORMAL
ACADEMIC)

CANDIDATE
NAME

 ()

CLASS

 -

CENTRE
NUMBER

S				
---	--	--	--	--

INDEX
NUMBER

--	--	--	--	--

MATHEMATICS

4048/02

Paper 2

26 August 2019

Candidates answer on the Question Paper.

2 hours 30 minutes

No Additional Materials are required.

8.00 a.m. to 10.30 a.m.

READ THESE INSTRUCTIONS FIRST

Write your class, index number and name on the work you hand in.
Write in dark blue or black pen on both sides of the paper.
You may use an HB pencil for any diagrams or graphs.
Do not use staples, paper clips, glue or correction fluid.

Answer all questions

If working is needed for any question it must be shown with the answer.
Omission of essential working will result in loss of marks.
The use of an approved scientific calculator is expected, where appropriate.
If the degree of accuracy is not specified in the question, and if answer is not exact, give the answer to three significant figures. Give answers in degrees to one decimal place.
For π , use either your calculator value or 3.142, unless the question requires the answer in terms of π .

At the end of the examination, fasten all your work securely together.
The number of marks is given in brackets [] at the end of each question or part question.
The total number of marks for this paper is 100.

Parent's/ Guardian's Signature:

Setter: Miss Li Ziyi

For Examiner's Use	
TOTAL	100

This document consists of 25 printed pages

Compound interest

Mathematical Formulae

$$\text{Total amount} = P \left(1 + \frac{r}{100} \right)^n$$

Mensuration

Curved surface area of a cone = $\pi r l$

Surface area of a sphere = $4\pi r^2$

Volume of a cone = $\frac{1}{3}\pi r^2 h$

Volume of a sphere = $\frac{4}{3}\pi r^3$

Area of triangle $ABC = \frac{1}{2}ab \sin C$

Arc length = $r\theta$, where θ is in radians

Sector area = $\frac{1}{2}r^2\theta$, where θ is in radians

Trigonometry

$$\frac{a}{\sin A} = \frac{b}{\sin B} = \frac{c}{\sin C}$$

$$a^2 = b^2 + c^2 - 2bc \cos A$$

Statistics

$$\text{Mean} = \frac{\sum fx}{\sum f}$$

$$\text{Standard deviation} = \sqrt{\frac{\sum fx^2}{\sum f} - \left(\frac{\sum fx}{\sum f} \right)^2}$$

Answer all the questions.

- 1 (a) Solve the inequality $\frac{2+3x}{5} \leq \frac{3-x}{2}$. [2]

$$\frac{2+3x}{5} \leq \frac{3-x}{2}$$

$$4+6x \leq 15-5x \quad [M1]$$

$$11x \leq 11$$

$$x \leq 1 \quad [A1]$$

- (b) Simplify $\frac{16x^2 - y^2}{4x^2 + 9xy + 2y^2}$. [3]

$$\frac{16x^2 - y^2}{4x^2 + 9xy + 2y^2} = \frac{(4x+y)(4x-y)}{(4x+y)(x+2y)}$$

$$\frac{4x-y}{x+2y} \quad [A1]$$

- (c) Given that $x = -\frac{1}{2}$ is a solution of $(m-1)x^2 + (m-2)x = 2m-15$, find the value of m and the second possible value of x . [3]

since $x = -\frac{1}{2}$ is a solution,

$$(m-1)\left(-\frac{1}{2}\right)^2 + (m-2)\left(-\frac{1}{2}\right) = 2m-15 \quad [M1]$$

$$\frac{1}{4}m - \frac{1}{4} - \frac{1}{2}m + 1 = 2m-15$$

$$\frac{63}{4} = \frac{9}{4}m$$

$$m = 7. \quad [A1]$$

$$6x^2 + 5x = -1$$

$$6x^2 + 5x + 1 = 0$$

$$(3x+1)(2x+1) = 0$$

$x = -\frac{1}{3}$ is the second possible value. [A1]

- (d) Solve the equation $x+5 = \frac{15x-1}{3x-1}$. [3]

$$(x+5)(3x-1) = 15x-1 \quad [M1]$$

$$3x^2 - x + 15x - 5 = 15x - 1$$

$$3x^2 - x - 4 = 0$$

$$(3x-4)(x+1) = 0 \quad [M1]$$

$$\therefore x = -1 \text{ or } \frac{4}{3} \quad [A1]$$

2 $\vec{AB} = \begin{pmatrix} 3 \\ -2 \end{pmatrix}$ and $\vec{OB} = \begin{pmatrix} 4 \\ 0 \end{pmatrix}$, where O is the origin.

(a) Find the length of AB .

[1]

$$\begin{aligned} AB &= \sqrt{3^2 + (-2)^2} \\ &= \sqrt{13} \\ &= 3.605551275 \\ &= 3.61 \text{ units.} \end{aligned}$$

[B1]

(b) Find the equation of line AB .

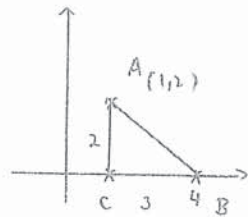
[2]

$$\begin{aligned} \text{grad of } AB &= \frac{-2}{3} \\ \text{subst. } m &= \frac{-2}{3} \text{ and } (4, 0) \text{ into } y = mx + c. \\ 0 &= \frac{-2}{3}(4) + c \\ c &= 2\frac{2}{3} \\ \text{Eqn of } AB &: y = \frac{-2}{3}x + 2\frac{2}{3} \end{aligned}$$

(c) C is a point on x -axis such that angle ACB is a right angle.

Find the tangent of angle ABC .

[2]



$$\tan \angle ABC = \frac{2}{2}$$

[C1]

(d) The equation of the line m is $3y + 2x = 6$. Line m intersects the x -axis at D and y -axis at E .

(i) Show how you can tell that the line m does not intersect the line AB .

[2]

$$\text{line } m: 3y + 2x = 6$$

$$y = \frac{-2}{3}x + 2$$

$$\text{grad of } m = \frac{-2}{3}$$

[M1] - find grad of m .

since line m is parallel to line AB and has a different y -intercept, they will not intersect one another. [B1]

(ii) Find \vec{ED} .

[2]

for D , at $y = 0$

for E , at $x = 0$, $y = 2$.

$$\vec{ED} = \vec{OD} - \vec{OE}$$

$$= \begin{pmatrix} 3 \\ 0 \end{pmatrix} - \begin{pmatrix} 0 \\ 2 \end{pmatrix}$$

$$= \begin{pmatrix} 3 \\ -2 \end{pmatrix}$$

(iii) What type of quadrilateral is $ABDE$? Explain your answer.

[3]

\vec{DE} is parallel to \vec{AB} because $\vec{ED} = \vec{AB}$. [B1]

$$\vec{BD} = \begin{pmatrix} -4 \\ 0 \end{pmatrix} + \begin{pmatrix} 3 \\ 0 \end{pmatrix}$$

$$= \begin{pmatrix} -1 \\ 0 \end{pmatrix}$$

$$\vec{AE} = \begin{pmatrix} -1 \\ -2 \end{pmatrix} + \begin{pmatrix} 0 \\ 2 \end{pmatrix}$$

$$= \begin{pmatrix} -1 \\ 0 \end{pmatrix}$$

\vec{AE} is also parallel to \vec{BD} because $\vec{AE} = \vec{BD}$. [M1]

$\therefore ABDE$ is a parallelogram because it has 2 pairs of parallel lines. [B1]

3 Rashidi wants to make a closed rectangular box to contain his toys. The box has a rectangular base of sides $3x$ cm and x cm and its height is h cm.

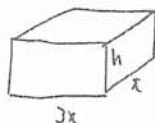
(a) (i) The volume of the box is 90 cm^3 .

[1]

Express h in terms of x .

$$\begin{aligned} 90 &= (3x)(x)(h) \\ h &= \frac{90}{3x} \\ &= \frac{30}{x} \quad \text{[A1]} \end{aligned}$$

(ii) Show that the total surface area of the box $A \text{ cm}^2$, is given by $A = \frac{240}{x} + 6x^2$. [2]



$$\begin{aligned} A &= 2hx + 2(3x)(h) + 2(3x)(x) \quad \text{[M1]} \\ &= 8hx + 6x^2 \\ &= 8\left(\frac{30}{x}\right)x + 6x^2 \\ &= \frac{240}{x} + 6x^2 \quad \text{[A1]} \end{aligned}$$

The table shows some corresponding values of x and A , correct to the nearest integer.

x	1	2	3	4	5	6	7	8
A	246	144	134	156	b	256	328	414

(a) Find the value of b .

[1]

$$\begin{aligned} b &= \frac{240}{5} + 6(5)^2 \\ &= 118 \quad \text{[A1]} \end{aligned}$$

(b) Using a scale of 2 cm to represent 1 unit, draw a horizontal x -axis for $0 \leq x \leq 8$.
Using a scale of 2 cm to represent 50 units, draw a vertical A -axis for $0 \leq A \leq 500$.

On your axes, plot the points given in the table and join them with a smooth curve on the grid in page 9. [3]

(c) By drawing a tangent, find the gradient of the curve at $(2, 144)$. [2]

[2]

$(1, 140)$ and $(6, 0)$

$$\begin{aligned} \text{grad} &= \frac{180 - 0}{1 - 6} \\ &= -36 \end{aligned}$$

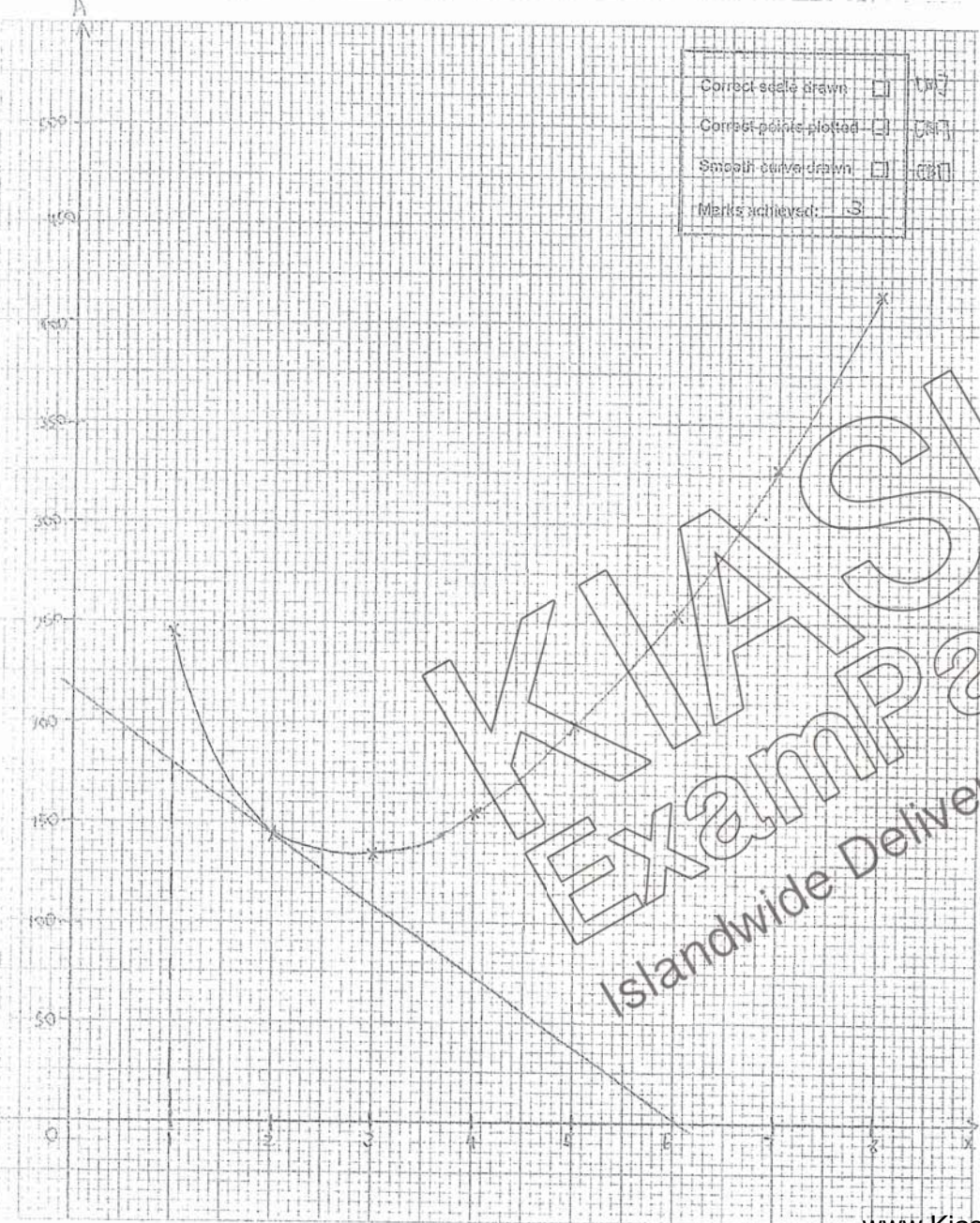
[M1]: draw tangent at correct point.

[A1]: $-40.5 \leq \text{grad} \leq -31.9$

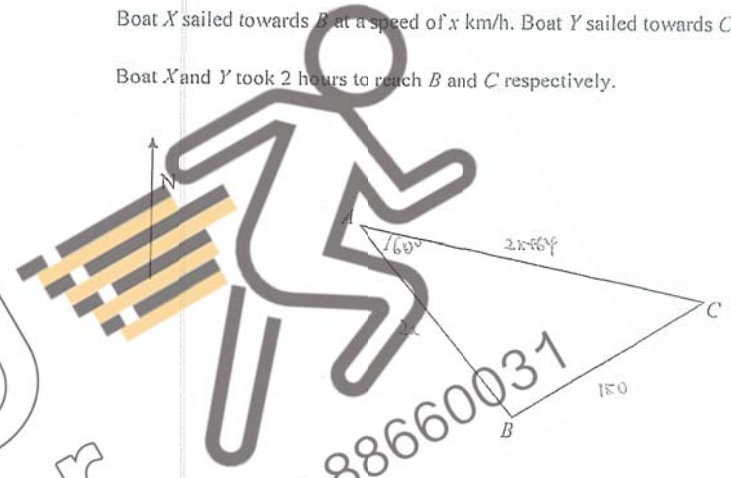
(d) Rashidi wants to make a box with a total surface area of 100 cm^2 without changing the volume of the box. Is it possible to do so? Explain your answer. [2]

[2]

It is not possible to do so because the box with the smallest possible surface area is approximately 185 cm^2 . [M1]



- 4 A, B and C represent three islands.
 Both boats X and Y left from island A .
 The bearings of B and C from A is 160° and 100° respectively.
 Boat X sailed towards B at a speed of x km/h. Boat Y sailed towards C at a speed of $(x+32)$ km/h.
 Boat X and Y took 2 hours to reach B and C respectively.



- (a) Write an expression, in terms of x , for the distance travelled by Boat X . [1]

$$\text{Dist.} = 2 \times x$$

$$= 2x$$
 [1]
- (b) B and C are 150 km apart. [4]

Write down an equation in x to represent this information and show that it reduces to

$$x^2 + 32x - 4601 = 0.$$

$\angle BAC = 160^\circ - 100^\circ$ [1]
 $= 60^\circ$
 $150^2 = (2x)^2 + (2x+64)^2 - 2(2x)(2x+64) \cos 60^\circ$ [1]
 $22500 = 4x^2 + 4x^2 + 356x + 4096 - 4x^2 - 128x$ [1]
 $4x^2 + 128x - 18404 = 0$
 $x^2 + 32x - 4601 = 0$ [1]

(b) Solve the equation $x^2 + 32x - 4601 = 0$.

[3]

$$\begin{aligned} x &= \frac{-32 \pm \sqrt{(32)^2 - 4(1)(-4601)}}{2} \quad [M1] \\ &= \frac{-32 \pm \sqrt{19428}}{2} \\ &= \frac{53.69218034 \text{ or } -85.69218034}{2} \\ &= 53.7 \text{ or } -85.7 \quad [A1], [A1] \end{aligned}$$

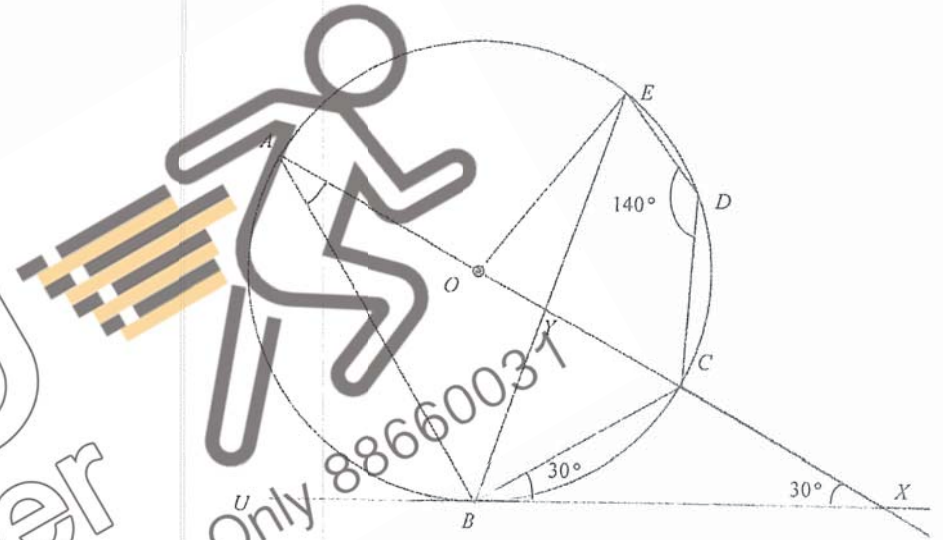
(c) Boat X returned from B to A and took 30 more minutes than the onward journey.

[2]

Find the speed of Boat X for the return journey.

$$\begin{aligned} \text{speed} &= \frac{2 \times 53.69218034}{2.5} \quad [M1] \\ &= 42.95374427 \\ &= 43.0 \text{ km/h.} \quad [A1] \end{aligned}$$

5 O is the centre of the circle passing through A, B, C, D and E . UBX is the tangent to the circle at B . ACX is a straight line which passes through O . $\angle CBX = \angle CXB = 30^\circ$ and $\angle EDC = 140^\circ$.



(a) Stating your reasons clearly, find,

(i) $\angle BAC$,

[2]

Note:
Alternative solution
 $\angle BAC = 30^\circ$ [As in alt. segment]
→ [A2]

$\angle BCA = 30^\circ + 30^\circ$ [M1] (ext \angle in a triangle)
 $\angle ABC = 60^\circ$ (ref \angle in a semicircle)
 $\angle BAC = 180^\circ - 60^\circ - 90^\circ$ (sum of \angle in a triangle)
 $= 30^\circ$ [A1]

(ii) $\angle CEB$, [1]

$\angle CEB = 30^\circ$ [1] (As in the same segment).

(iii) $\angle CBE$, [1]

$\angle CBE = 180^\circ - 140^\circ$ (As in opp. segment)
 $= 40^\circ$ [1]

(iv) $\angle OBY$, $\angle OBY = 90^\circ$ (tan is rad) [2]
 $\angle OBY = 90^\circ - 40^\circ - 30^\circ$
 $= 20^\circ$ [1]

(b) T is a point such that angle ATE is 60° and on the same side as B . [3]
 State whether point T lies in the circle.
 Explain your answer.

$\angle ABE = 20^\circ + 30^\circ$ (base angles of isos. \triangle) [1]
 $= 50^\circ$ [1]

$\therefore T$ lies inside the circle because $\angle ATE > 50^\circ$. [1]

6 Angela and Ruth went on a free-and-easy trip to Sydney.

(a) They both exchanged S\$1600 at a money changer in Singapore. The money changer used an exchange rate between Singapore dollars (S\$) and Australian dollars (A\$) of A\$ 1 = S\$0.95. [2]

Calculate the amount of Australian dollars they received.

Amount of A\$
 $= \frac{1600}{0.95}$ [1]
 $= A\$1684.210526$
 $= A\$1684.21$ [1]

(b) They booked their accommodation through the Waterbnb application. [2]

Each night at the accommodation costs A\$110.25. However, there was a 10% service charge. An additional 5% daily cleaning fee was imposed only on the cost of the accommodation.

They booked a total of 8 nights at the accommodation.

Calculate the total cost of their accommodation in Australian dollars.

Total cost. = $(8 \times 110.25) \times \frac{110}{100} + \frac{5}{100} \times (8 \times 110.25)$ [1]
 $= A\$1514.30$ [1]

- (c) Ruth also purchased a watch in Sydney. [3]

To pay for the watch, she borrowed S\$ 2340 for 2 years at an interest of 5.6% per annum compounded half-yearly.

Calculate the amount of interest she paid for the watch.

$$\begin{aligned}
 &\text{Amount of interest} \quad [1] \\
 &= 2340 \left(1 + \frac{5.6}{100} \right)^4 - 2340 \\
 &= \$ 273.294269 \\
 &= \$ 273.29 \quad [1]
 \end{aligned}$$

- (d) Sydney has a population of 4.627 million and Darwin has a population of 132 000. [2]

(i) Calculate how many more people live in Sydney than in Darwin, giving your answer in standard form.

$$\begin{aligned}
 &4.627 \times 10^6 - 132000 \quad [1] \\
 &= 4495000 \\
 &= 4.495 \times 10^6 \text{ more people} \quad [1]
 \end{aligned}$$

- 7 Hillgrove organised an annual school carnival to raise funds for a children's home.

Two different classes sold three different flavours of Bubble Tea to raise funds.

The table below shows the number of Bubble Tea sold by each class and the price of the Bubble Tea.

Flavours	Class 4-10	Class 4-11	Price per cup
Milk Oolong	30	20	\$1.90
Cheese Peach	20	40	\$3.20
Brown Sugar	15	10	\$2.50

- (a) Represent the number of different flavours of Bubble Tea sold by each class in a 3×2 matrix, F. [1]

$$F = \begin{pmatrix} 30 & 20 \\ 20 & 40 \\ 15 & 10 \end{pmatrix} \quad [1]$$

- (b) Represent the prices of Bubble Tea in a 1×3 matrix, P. [1]

$$P = (1.9 \quad 3.2 \quad 2.5) \quad [1]$$

- (c) Evaluate the matrix $R = PF$. [2]

$$\begin{aligned}
 R &= PF \\
 &= (1.9 \quad 3.2 \quad 2.5) \begin{pmatrix} 30 & 20 \\ 20 & 40 \\ 15 & 10 \end{pmatrix} \quad [1] \\
 &= (159.5 \quad 191) \quad [1]
 \end{aligned}$$

(d) Explain what each element in matrix R means.

[1]

8

The elements in R represents the total
amount of money 4-10 and 4-11
collected respectively. [1B]

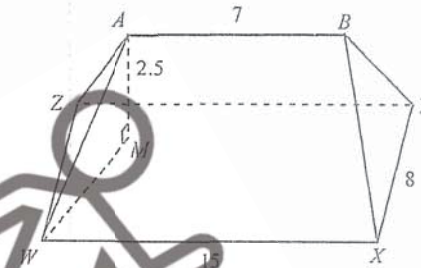
(e) M is $\begin{pmatrix} 1 \\ 1 \end{pmatrix}$. Evaluate $A = RM$ and explain what the element in A means.

[2]

$$A = (158.5 \ 191) \begin{pmatrix} 1 \\ 1 \end{pmatrix}$$

$$= (349.5) \quad [1A]$$

This element represents the total amount
of money collected from both 4-10 and 4-11. [1B]



The diagram represents the roof of a house. The ridge AB is horizontal and is built centrally above the rectangular plane $WXYZ$. AM is the height of the ridge above $WXYZ$. It is given that $WX = 15$ m, $XY = 8$ m, $AB = 7$ m and $AM = 2.5$ m.

(a) Show that WM is 5.657 m, correct to 4 significant figures.

[2]

$$\begin{aligned} WM &= \sqrt{4^2 + 4^2} \quad [1M] \\ &= 5.656854249 \\ &= 5.657 \text{ m} \quad [1A] \end{aligned}$$

(b) Find

(i) angle AWM ,

[2]

$$\begin{aligned} \tan \angle AWM &= \frac{2.5}{\sqrt{32}} \quad [1M] \\ \angle AWM &= 23.84263602 \\ &= 23.8^\circ \quad [1A] \end{aligned}$$

(ii) AW,

[2]

$$\begin{aligned}
 AW &= \sqrt{2.5^2 + 5.656854249^2} \quad [M1] \\
 &= 6.184858438 \\
 &= 6.18 \text{ m} \quad [A1]
 \end{aligned}$$

(iii) AX,

$$\sin \angle OBX = \frac{4}{6.184858438} \quad [M1]$$

$$\angle OBX = 40.29631692^\circ$$

$$\begin{aligned} \angle ABX &= 90^\circ + 40.29631692^\circ \quad [M1] \\ &= 130.2963169^\circ \end{aligned}$$

$$\angle AX = 7^\circ + 6.184858438^\circ - 2(7)(6.184858438) \cos 130.2963169^\circ \quad [M1]$$

$$AX = 11.96881255$$

$$= 12.0 \text{ m} \quad [A1]$$

(c) Find the smallest angle of elevation of A from a point along WX.

[2]

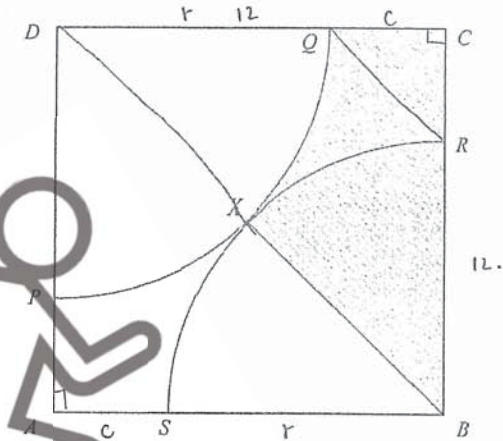
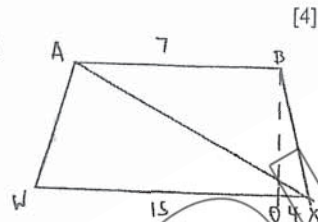
smallest \angle of elevation = $\angle AXM$

$$\sin \angle AXM = \frac{3.5}{11.96881255} \quad [M1]$$

$$\angle AXM = 12.0565044^\circ$$

\therefore smallest \angle

$$= 12.1^\circ \quad (\text{to 1 d.p.}) \quad [A1]$$



ABCD is a square of length 12 cm. DQP and BRS are two identical quadrants and arcs QP and RS meet at point X. BXD is a straight line.

(a) Find

(i) the perimeter of the shaded region,

[4]

$$DB = \sqrt{12^2 + 12^2} \quad [M1]$$

$$= \sqrt{288} \text{ cm.}$$

$$\text{radius of circle} = \frac{1}{2} \sqrt{288} \text{ cm.}$$

$$\text{Arc length } QS = r\theta$$

$$= \sqrt{288} \times \frac{\pi}{2} \quad [M1]$$

$$= \frac{\pi \sqrt{288}}{2}$$

$$\text{Perimeter} = \frac{\pi \sqrt{288}}{4} + [12 - \frac{1}{2} \sqrt{288}] + 12 + \frac{1}{2} \sqrt{288} \quad \text{And } \angle C: [M1]$$

$$= 37.32854831$$

$$= 37.3 \text{ cm} \quad [A1]$$

(ii) the area of QRX . [QRX is not a triangle.] [3]

Area of QRX

$$= \frac{(12 \times 12)}{2} - \left[\frac{1}{2} \left(\frac{\sqrt{336}}{2} \right)^2 \times \frac{\pi}{4} \right] \times 2 \quad [M1]$$

$$= 15.45133224 \text{ cm}^2$$

$$\text{Area of } QRX = 15.45133224 - \frac{1}{2} \times \left[12 - \frac{1}{2} \sqrt{336} \right]^2 \quad [M1]$$

$$= 9.274701726$$

$$= 9.27 \text{ cm}^2 \quad [A1]$$

(b) Show that triangle DAB is similar to triangle RCQ . [3]

$$\angle DAB = \angle RCQ = 90^\circ \quad (\text{square}) \quad [M1]$$

$$\angle ADB = 45^\circ \quad (\text{base } \angle \text{ of } \text{rt. triangle})$$

$$\angle CRQ = 45^\circ \quad (\text{base } \angle \text{ of } \text{rt. triangle}) \quad [M1]$$

$$= \angle ADB$$

$\therefore \triangle DAB$ is similar to $\triangle RCQ$ because their corresponding angles are equal. [A1]

10 There was a hit and run car accident along the Pan-Island Expressway (PIE). It was raining the day before and the road was wet. PIE has a speed limit of 80 km/h. The police needed to find out who the driver was and there were some items found at the scene.

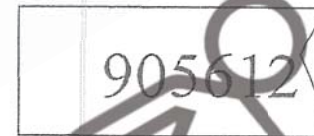


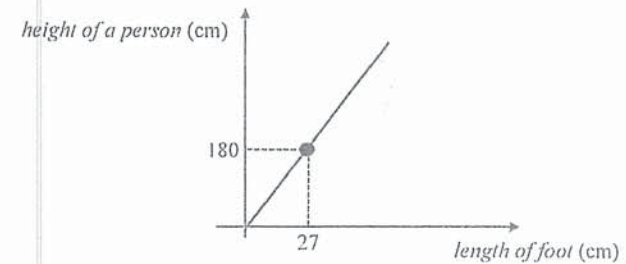
Exhibit A: slip of paper with driver's telephone number

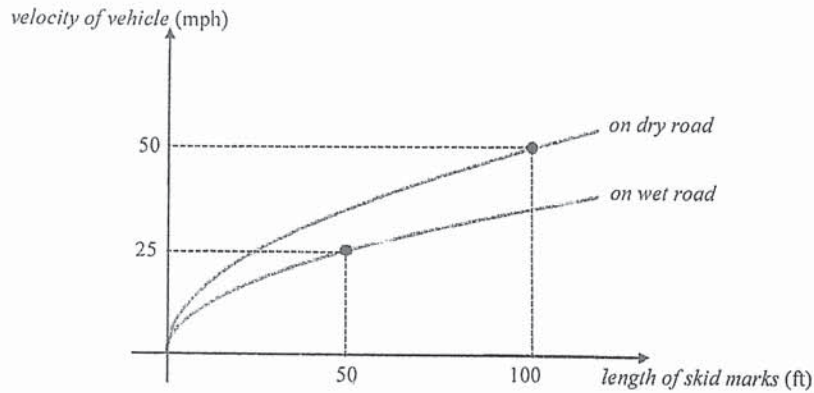


Exhibit B: driver's shoes print - 25 cm in length

Exhibit C: driver's vehicle skid marks - 350 ft. in length
It is given that the velocity of the car is directly proportional to the square root of the length of skid marks.

The police also uses graphs below to help them to solve crimes.





Length Conversion	
1 ft	0.3048 m
1 mile	1.609 km
<i>ft</i> – feet	
<i>mph</i> – miles per hour	

Note that the graphs only give predicted estimated values.

- (a) Given that there are 8-digits in the driver's telephone number, find the total number of possible telephone numbers. [2]

Total no. = 10×10 [1]
 $\times 10$ [1]

The police then narrowed to three suspects with their details below.

	Daniel Lee	Jacob Yap	Samuel Wong
Height	1.78 m	1.66 m	1.82 m
Brand of vehicle they own	Kia	Toyota	Volkswagen

Speed limit	Composition Fine	
	Light Vehicle <i>(Examples: motor cars, motorcycles, light goods van, etc.)</i>	Heavy Vehicle <i>(Examples: tractors, buses, trailers, etc.)</i>
Exceeding road speed limit by 1 – 20 km/h	\$150	\$200
Exceeding road speed limit by 21 – 30 km/h	\$200	\$250
Exceeding road speed limit by 31 – 40 km/h	\$300	\$400
Exceeding 41 km/h	prosecution in court	

- (b) Find the driver who was involved in the accident and determine the appropriate fine for speeding ticket. [7]

Justify your decision with calculations.

(b) let the height be h .

$$\frac{h}{25} = \frac{180}{27} \quad [M1]$$

$$h = 166 \frac{2}{3} \text{ cm.}$$

since velocity of car is directly proportional to
square root of length of skid marks,

$$v = k\sqrt{l}, \text{ where } k \text{ is a constant.}$$

$$25 = k\sqrt{50} \quad [M1]$$

$$k = \frac{25}{\sqrt{50}}$$

$$v = \frac{25}{\sqrt{50}}\sqrt{l}$$

to find velocity at that instant,

$$v = \frac{25}{\sqrt{50}} \times \sqrt{350} \quad [M1]$$

$$= 66.14378278 \text{ mph}$$

$$= 66.14378278 \times 1.609 \quad [M1]$$

$$= 106.4253765 \text{ km/h.}$$

$$\text{Exceed} = \sqrt{106.4253765} - 80$$

$$= 26.4253765$$

$$= 26.4 \text{ km/h.} \quad [M1]$$

∴ The driver is Jacob Yap

and he has to pay \$200 fine. [M1]



KIASU
Exam Paper
Islandwide Delivery | Whatsapp Only 88660031



HILLGROVE SECONDARY SCHOOL
PRELIMINARY EXAMINATION 2019
SECONDARY 4 (EXPRESS) / 5 (NORMAL
ACADEMIC)

CANDIDATE NAME () CLASS -

CENTRE NUMBER INDEX NUMBER

MATHEMATICS 4048/01

Paper 1 22 August 2019

Candidates answer on the Question Paper. 2 hours
No Additional Materials are required. 8.00 a.m. to 10.00 a.m.

READ THESE INSTRUCTIONS FIRST

Write your class, index number and name on the work you hand in.
Write in dark blue or black pen.
You may use an HB pencil for any diagrams or graphs.
Do not use staples, paper clips, glue or correction fluid.

Answer all questions
If working is needed for any question it must be shown with the answer.
Omission of essential working will result in loss of marks.
The use of an approved scientific calculator is expected, where appropriate.
If the degree of accuracy is not specified in the question, and if answer is not exact, give the answer to three significant figures. Give answers in degrees to one decimal place.
For π , use either your calculator value or 3.142, unless the question requires the answer in terms of π .

At the end of the examination, fasten all your work securely together.
The number of marks is given in brackets [] at the end of each question or part question.
The total number of marks for this paper is 80.

Parent's/ Guardian's Signature:

Setter: Miss Li Ziyi

For Examiner's Use	
TOTAL	80

This document consists of 21 printed pages.

Mathematical Formulae

Compound interest

$$\text{Total amount} = P \left(1 + \frac{r}{100} \right)^n$$

Mensuration

$$\text{Curved surface area of a cone} = \pi r l$$

$$\text{Surface area of a sphere} = 4\pi r^2$$

$$\text{Volume of a cone} = \frac{1}{3} \pi r^2 h$$

$$\text{Volume of a sphere} = \frac{4}{3} \pi r^3$$

$$\text{Area of triangle } ABC = \frac{1}{2} ab \sin C$$

$$\text{Arc length} = r\theta, \text{ where } \theta \text{ is in radians}$$

$$\text{Sector area} = \frac{1}{2} r^2 \theta, \text{ where } \theta \text{ is in radians}$$

Trigonometry

$$\frac{a}{\sin A} = \frac{b}{\sin B} = \frac{c}{\sin C}$$

$$a^2 = b^2 + c^2 - 2bc \cos A$$

Statistics

$$\text{Mean} = \frac{\sum fx}{\sum f}$$

$$\text{Standard deviation} = \sqrt{\frac{\sum fx^2}{\sum f} - \left(\frac{\sum fx}{\sum f} \right)^2}$$

Answer all the questions.

- 1 Write the following numbers in order of size, starting with the largest.

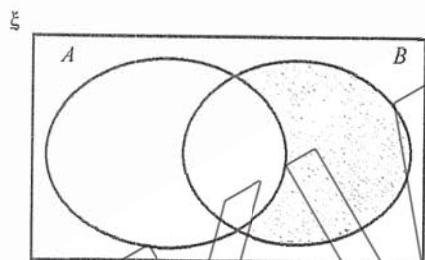
$$\frac{37}{100}, 0.3\dot{7}, 0.\dot{3}7, \left(\frac{37}{100}\right)^2$$

$$\frac{37}{100} = 0.37, \left(\frac{37}{100}\right)^2 = 0.1369.$$

Answer 0.37, 0.37, $\frac{37}{100}$, $\left(\frac{37}{100}\right)^2$ [1]
[B1]

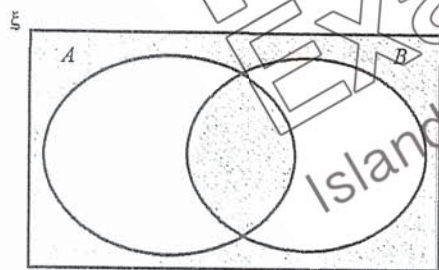
- 2 Write down the sets represented by the following shaded regions.

(a)



Answer $A \cap B$ [B1] [1]

(b)



Answer $(A \cup B)' \cup (A \cap B)$ [B1] [1]

- 3 Show that $(1+5n)^2 - 6$ is a multiple of 5 for all integer values of n .

Answer

$$(1+5n)^2 - 6 = 1 + 10n + 25n^2 - 6$$

$$= 25n^2 + 10n - 5 \quad [M1]$$

$$= 5(5n^2 + 2n - 1)$$

since $(1+5n)^2 - 6$ has a factor of 5, [A1]
 $(1+5n)^2 - 6$ is a multiple of 5.

[2]

- 4 (a) Express $x^2 - 6x + 5$ in the form of $(x-a)^2 + b$.

$$x^2 - 6x + 5 = x^2 - 6x + \left(-\frac{6}{2}\right)^2 - \left(\frac{6}{2}\right)^2 + 5$$

$$= (x-3)^2 - 4$$

Answer $(x-3)^2 - 4$ [A1] [1]

- (b) Hence, solve $x^2 - 6x + 5 = 0$.

$$(x-3)^2 - 4 = 0$$

$$(x-3)^2 = 4$$

$$x-3 = \pm 2$$

$$x = 5 \quad \text{or} \quad 1$$

← together →

Answer 5 or 1 [A1] [1]

5 Nithya runs a photography club.

Her club currently has 62 boys and 39 girls.

Her aim is to have at least 45% of members to be girls.

Find the smallest number of girls required to join her club.

Alternative solⁿ:

Let the smallest no. of girls be x .

$$\frac{39+x}{62+39+x} \times 100\% \geq 45\% \quad [M1]$$

$$\frac{39+x}{62+39+x} \times 100\% = 45\% \quad [M1]$$

$$\frac{39+x}{101+x} \geq 0.45$$

$$\frac{39+x}{101+x} = 0.45$$

$$39+x \geq 0.45(101+x)$$

$$39+x = 0.45(101+x)$$

$$0.55x \geq 6.45$$

$$x - 0.45x = 45 - 45 - 39$$

$$x \geq 11\frac{8}{11}$$

$$0.55x = 6.45$$

$$x = 11\frac{8}{11}$$

Smallest no. = 12. [A1]

\therefore smallest no. = 12.

Answer 12. [A1] [2]

6 A pizza is divided in the ratio of 3 : 7 : 5 for Adrian, Ben and Carl respectively. Ben then divides his share in the ratio of 9 : 7 and give it to Adrian and Carl respectively.

Carl says that both he and Adrian have the same amount of pizza now.

Do you agree with Carl? Explain your answer.

Answer

A = B : C
3 : 7 : 5
No. Carl has more [A1]

$\frac{3}{7} : 1 = \frac{5}{7}$
please refer Adrian

$\frac{48}{7} : 16 = \frac{80}{7}$

No. of units of pizza Adrian has = $\frac{48}{7} + 9$

= $15\frac{6}{7}$

No. of units of pizza Carl has = $\frac{80}{7} + 7$

= $18\frac{3}{7}$

[M1] : finding Adrian's / Carl's pizza. [2]

7 It is given that $y = \frac{3x+5b}{x-2c}$.

(a) Find y when $x=1, b=2, c=4$.

$$y = \frac{3(1) + 5(2)}{1 - 2(4)}$$

$$= -\frac{6}{7}$$

Answer $-\frac{6}{7}$ [A1] [1]

(b) Express x in terms of y, b and c .

$$y = \frac{3x+5b}{x-2c}$$

$$xy - 2cy = 3x + 5b$$

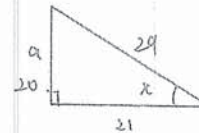
$$xy - 3x = 2cy + 5b$$

$$x(y-3) = 2cy + 5b \quad [M1]$$

$$x = \frac{2cy + 5b}{y-3}$$

Answer $x = \frac{2cy + 5b}{y-3}$ [A1] [2]

8 Given that $\cos x = \frac{21}{29}$, where x is an acute angle, find the value of $\sin x + \cos(180^\circ - x) - \tan x$ without the use of calculator.



$$a = \sqrt{29^2 - 21^2} \quad [M1]$$

$$= 20.$$

$$\sin x + \cos(180^\circ - x) - \tan x$$

$$= \frac{20}{29} - \frac{21}{29} - \frac{20}{21} \quad [M1]$$

$$= -\frac{601}{609}$$

Answer $-\frac{601}{609}$ [A1] [3]

- 9 (a) The product of three prime numbers a , b and c is m , where m is an even number.

The smallest and the largest number out of the three prime numbers are a and c respectively. $c > a$.

State the value of a and explain your answer.

Answer a must be 2. (1) for m to be an even number,
one of the three prime numbers must be even. 2 is the
only even prime number. (1)

[2]

- (b) Given that $b = 23$ and m is less than 670, find the largest possible value of c .

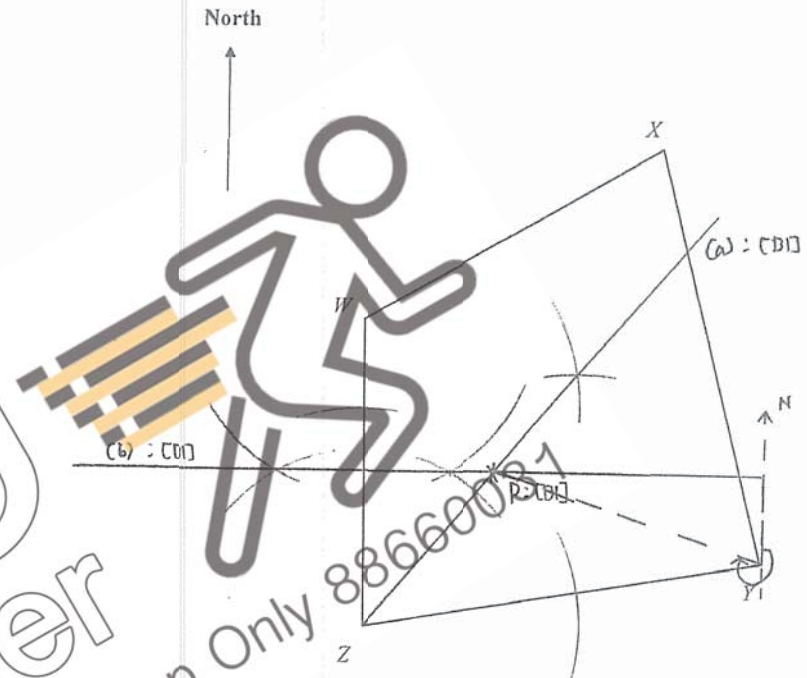
$$2 \times 23 \times c < 670 \quad (1)$$

$$c < 14 \frac{13}{23}$$

$$\therefore \text{largest } c = 13 \quad (1)$$

Answer 13 [2]

- 10 The diagram shows a plot of land labelled $WXYZ$.



- (a) Construct the bisector of angle WZY . [1]
 (b) Construct the perpendicular bisector of WZ . [1]
 (c) (i) The government is planning to build a playground that is equidistant from W and Z and WZ and YZ . Mark and label the location of the playground as P . [1]
 (ii) Hence, find the bearing of P from Y .

Answer $227.5^\circ \pm 1^\circ$ [1]
 (1)

11 (a) Given that $4(x+2y) = 5x - 3y$, find the ratio of $x : y$.

$$4x + 8y = 5x - 3y$$

$$11y = x$$

$$\frac{x}{y} = \frac{11}{1} \quad [M1]$$

$$\therefore x : y \Rightarrow 11 : 1$$

Answer 11 : 1 [A1] [2]

(b) Solve $\frac{27^b}{9} = 81^{b+1}$.

$$\frac{27^b}{9} = 81^{b+1}$$

$$\frac{3^{3b}}{3^2} = (3^4)^{b+1}$$

$$3^{3b-2} = 3^{4b+4}$$

$$3b-2 = 4b+4$$

$$-b = 6$$

$$b = -6$$

Answer b = -6 [2]

12 Winnie is drawing an n -sided regular polygon.

The total sum of the interior angles is h° .

Given that $h + n = 1631$, find the values of h and n .



$$(n-2) \times 180^\circ = h \quad [M1] \text{ : form this eqn.}$$

$$180n - 360 = h \quad \text{--- (1)}$$

$$h + n = 1631 \quad \text{--- (2)}$$

subst (1) into (2).

$$180n - 360 + n = 1631 \quad [M1]$$

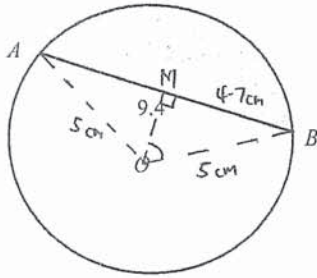
$$181n = 1991$$

$$n = 11 \quad [A1]$$

$$h = 1631 - 11$$

$$= 1620 \quad [A1]$$

Answer $h =$ 1620
 $n =$ 11 [4]



In the diagram, A and B are points on a circle, centre O . The radius of the circle is 5 cm and length of AB is 9.4 cm.

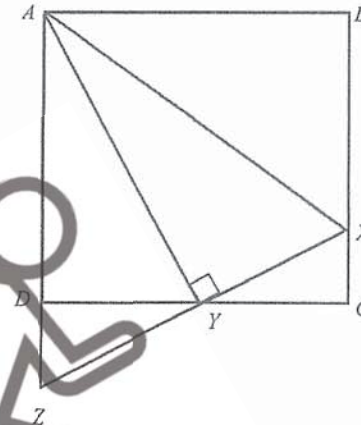
Find the area of the minor segment AB .

$\sin \angle MOB = \frac{4.7}{5}$ [M1]: find $\angle AOB$
[M1] carry method)

$\angle AOB = 2 \times \sin^{-1} \left(\frac{4.7}{5} \right)$
 $= 140.1031128^\circ$

Area of minor segment AB [M1] find sector area
 $= \frac{140.1031128}{360} \times \pi(5)^2 - \frac{1}{2}(5)^2 \sin 140.1031128^\circ$
 $= 22.54815724$
 $= 22.5 \text{ cm}^2$ [A1]

Answer 22.5 cm² [4]



$ABCD$ is a square and AY is perpendicular to XZ . XYZ and ADZ are straight lines. Y is the midpoint of CD .

(a) Show that triangle DYZ is congruent to triangle CYX .

$\angle DYZ = \angle CYX$ (vert. opp. \angle)

$DY = CY$ (Y is the midpoint) [M1]

$\angle YDZ = 180^\circ - 90^\circ = 90^\circ$ (adj. \angle on str. line)

$= \angle YCX$ (square). [2]

$\therefore \Delta DYZ$ is congruent to ΔCYX . (ASA) [A1]

(ii) Show that $AZ = AX$.

$AY = AY$ (common)

$\angle DYZ = \angle CYX$ (because ΔDYZ is congruent to ΔCYX)

$\angle AYZ = \angle AYC = 90^\circ$ (adj. \angle on a str. line). [M1]

ΔAYZ is congruent to ΔAYC . (SAS). [2]

$\therefore AZ = AX$. [A1]

- 15 Serene has two boxes of cards.
One box contains cards that has either a circle or a square.
The other box contain cards that are green or blue in colour.

Serene picks a card from each box at random.
The probability that she picks a circle card is c .
The probability that she picks a green card is g .

- (a) Complete the table for the card that Serene picks, writing each probability in terms of c and g .

Event	Probability
Circle and Green	cg
Square and Green	$(1-c)g$
Circle and Blue	$c(1-g)$
Square and Blue	$(1-c)(1-g)$

[B1]: any 2 correct

[B2]: all 4 correct

[2]

- (b) The probability that she picks a circle card is $\frac{2}{7}$.

The probability that she picks a circle card and green card is $\frac{1}{5}$.

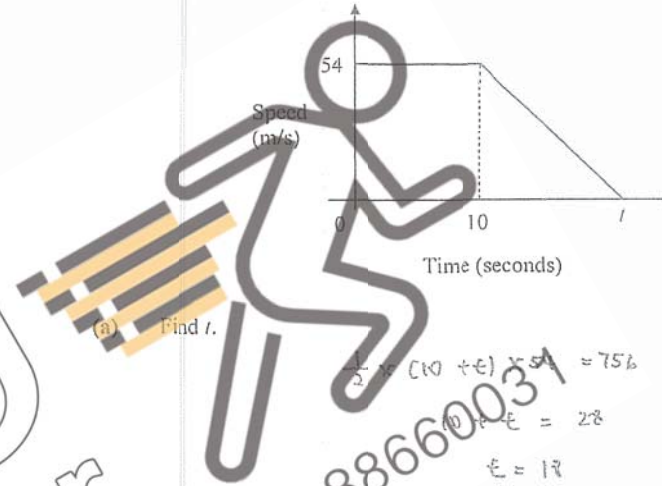
Hence, or otherwise, find the total number of green cards given that the total number of blue and green cards is 30.

$\therefore c = \frac{2}{7}$
 $cg = \frac{1}{5}$
 $(\frac{2}{7})g = \frac{1}{5}$
 $g = \frac{1}{5} \times \frac{7}{2}$
 $g = \frac{7}{10}$
 \therefore total no. of green cards
 $= \frac{7}{10} \times 30$
 $= 21$. [A1]

[M1]: substit. $c = \frac{2}{7}$
 Answer 21 [3]

- 16 The diagram shows the speed – time graph for a truck's journey.

The distance travelled for the first t seconds is 756 m.



$\frac{1}{2} \times (10 + t) \times 54 = 756$ [M1]
 $10 + t = 28$
 $t = 18$ [A1]

Answer $t = 18$ [2]

- (b) Calculate the deceleration at the 15th second of the journey.

acceleration = $\frac{54 - 0}{10 - 12}$ [M1]
 $= -6\frac{3}{4} \text{ m/s}^2$
 \therefore deceleration = $6\frac{3}{4} \text{ m/s}^2$ [A1]

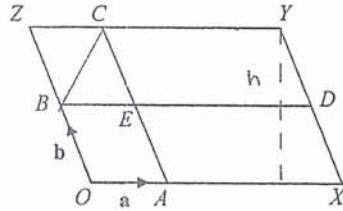
Answer $6\frac{3}{4} \text{ m/s}^2$ [2]
 or 6.75 m/s^2

- (c) Find the average speed in km/h.

Average speed = $\frac{756 \div 1000}{18 \div 3600}$ [M1]
 $= 151.2 \text{ km/h}$ [A1]

Answer 151.2 km/h or $151\frac{1}{5} \text{ km/h}$ [2]

17 The diagram shows a parallelogram $OXYZ$.



$\vec{OA} = \mathbf{a}$ and $\vec{OB} = \mathbf{b}$. BE and AD are lines parallel to the sides of the parallelogram.
 $\vec{OX} = 3\vec{OA}$ and $\vec{OZ} = 2\vec{OB}$.

(a) Express \vec{EY} in terms of \mathbf{a} and \mathbf{b} , as simply as possible.

$$\frac{OX}{OA} = \frac{3}{1}, \quad \frac{OZ}{OB} = \frac{2}{1} \quad \vec{EY} = \vec{AD} \quad [M1]$$

$$= \vec{AX} + \vec{XD}$$

$$= 2\mathbf{a} + \mathbf{b} \quad [A1] \text{ or } [B2]$$

Answer $2\mathbf{a} + \mathbf{b}$ [2]

(b) Write down two vectors that can be written as $\mathbf{b} - 3\mathbf{a}$.

Answer \vec{XB} and \vec{DZ} [2]

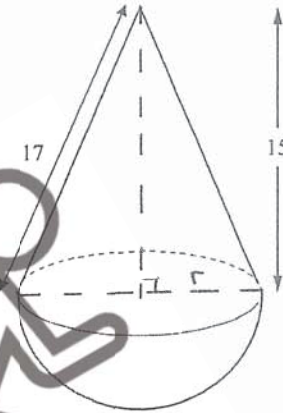
(c) Find the ratio of the area of triangle BCE to the area of parallelogram $OXYZ$.

let h be the height of $OXYZ$.

$AOBE$:	$OXYZ$		BCE	:	$OXYZ$
$\frac{h}{2} \times 1$:	$h \times 3$		$\frac{1}{2} \times 1$:	$h \times 3$
$\frac{1}{2}$:	3		1	:	6
1	:	6				

Answer $1:6$ [2]

18



The diagram shows a toy that combines a cone and a hemisphere. The slant height of the cone is 17 cm and the perpendicular height of the cone is 15 cm.

(a) Show that the radius of the hemisphere is 8 cm.

Let radius be r .

$$r = \sqrt{17^2 - 15^2} \quad [M1]$$

$$= 8 \text{ cm.}$$

\therefore radius = 8 cm [A1]

(b) Calculate the surface area of the toy.

$$\text{surface area} = \pi r l + 2\pi r^2$$

$$= \pi(8)(17) + 2\pi(8)^2 \quad [M1]: \text{ add curved s.a of cone + s.a of hemisphere}$$

$$= 829.3804605$$

$$= 829 \text{ cm}^2 \quad [A1] \quad [M1]: \text{ find curved s.a of cone}$$

Answer 829 cm^2 [3]

- (c) The company wants to make a miniature version of the toy such that the volume of the miniature toy is $\frac{1}{6}$ of the volume of the actual toy.

Calculate the radius of the miniature toy.

r_s be radius of miniature toy.

$$\left(\frac{r_s}{8}\right)^3 = \frac{1}{6} \quad [M1]$$

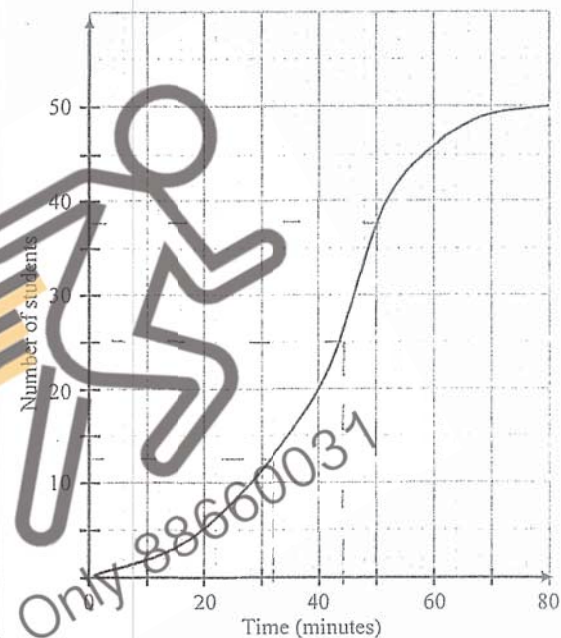
$$r_s^3 = 85\frac{1}{3}$$

$$r_s = 4.40256$$

$$= 4.40 \text{ cm} \quad [A1]$$

Answer 4.40 cm [2]

- 19 The travelling times taken by 50 students from home to school are recorded. The cumulative frequency curve below shows the distribution of their times.



Use your graph to estimate

- (i) the median

$$Q_2 = 44 \text{ mins}$$

Answer 44 mins [1]

- (ii) the interquartile range

$$Q_1 = 32, \quad Q_3 = 50$$

$$\text{IQR} = 50 - 32 \quad [M1]$$

$$= 18 \quad [A1]$$

Answer 18 [2]

KIASU
ExamPaper
Islandwide Delivery | Whatsapp Only 88660031

- (b) Find the probability that two students, chosen at random, take less than 70 minutes to travel to school.

$$P(2 \text{ students took less than } 70 \text{ mins}) = \frac{49}{50} \times \frac{49}{49} \quad [M1]$$

$$= \frac{24}{25} \quad [A1]$$

Answer $\frac{24}{25}$ [2]

- (c) A student states that 32% of the students took at least 36 minutes to travel to school.

Comment on whether the data from the school supports this claim.

Answer No. of students who took at least 36 mins = $50 - 16$ [M1]

$$= 34.$$

$$\frac{34}{50} \times 100\% = 68\% \text{ took at least 36 mins, not 32\%. [A1]}$$

[2]

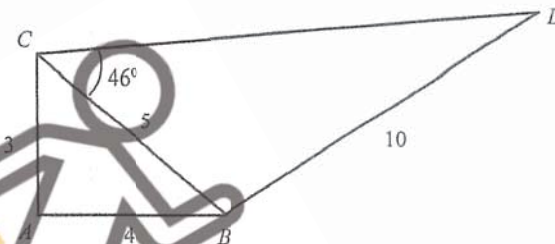
or

$$32\% \rightarrow \frac{32}{100} \times 50 = 16 \text{ students.}$$

16 students took less than 36 mins, not at least 36 mins. [M1]

[2]

- 20 The diagram shows two triangles ABC and BDC .



$AC = 3 \text{ cm}$, $AB = 4 \text{ cm}$, $BC = 5 \text{ cm}$, $BD = 10 \text{ cm}$ and $\angle CBD = 113^\circ$.

- (a) Show that $\angle CAB$ is a right angle.

$$AC^2 + AB^2 = 3^2 + 4^2$$

$$= 25$$

$$BC^2 = 5^2$$

$$= 25$$

[M1]

Since $AC^2 + AB^2 = BC^2$, by converse of Pythagoras' theorem, $\angle CAB$ is a right angle. [A1]

[2]

- (b) Find $\angle BDC$.

or

$$\frac{\sin \angle BDC}{5} = \frac{\sin 46^\circ}{10} \quad [M1]$$

$$\angle BDC = 180^\circ - 46^\circ - 113^\circ \quad [M1]$$

$$= 21^\circ \quad [A1]$$

$$\angle BDC = 21.079924$$

$$= 21.1^\circ \quad [A1]$$

Answer 21.1° [2]

(c) Find the area of $ABDC$.

$$\begin{aligned} \text{Area of } ABDC &= \left[\frac{1}{2} \times 3 \times 4 \right] + \left[\frac{1}{2} \times 5 \times 10 \times \sin 113^\circ \right] \quad [M1] \\ &= 29.0126 \\ &= 29.0 \text{ cm}^2 \quad [A1] \end{aligned}$$

Answer 29.0 cm² [2]

(d) A circle is drawn through the points A , B and C . State the length of the diameter of the circle. Explain your answer.

Diameter = 5 cm. [B] Since $\angle CAB = 90^\circ$, BC must be the diameter due to the property of right angle in a semicircle. [B]

[2]



KIASU
ExamPaper
Islandwide Delivery | Whatsapp Only 88660031