

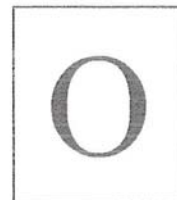

BEATTY SECONDARY SCHOOL
PRELIMINARY EXAMINATION 2019



SUBJECT : Mathematics

LEVEL : Sec 4E/5N

PAPER : 4048 / 01

DURATION : 2 hours

SETTER : Mr Leong S C

DATE : 26 Aug 2019

CLASS :	NAME :	REG NO :
---------	--------	----------

READ THESE INSTRUCTIONS FIRST

Write your name, class and index number in the spaces on the top of this page.

Write in dark blue or black pen.

You may use a pencil for any diagrams or graphs.

Do not use staples, paper clips, highlighters, glue or correction fluid.

Answer **all** questions.

If working is needed for any question, it must be shown with the answer.

Omission of essential working will result in loss of marks.

The use of an approved scientific calculator is expected, where appropriate.

If the degree of accuracy is not specified in the question, and if the answer is not exact, give the answer to three significant figures. Give answers in degrees to one decimal place.

For π , use either your calculator value or 3.142, unless the question requires the answer in terms of π .

The number of marks is given in brackets [] at the end of each question or part question.

The total number of marks for this paper is 80.

For Examiner's Use
80

This paper consists of 18 printed pages (including this cover page)

[Turn Over

1. The first 4 terms of a sequence of numbers T_1, T_2, T_3 and T_4 are given below:

$$T_1 = 1^2 + 2^2 = 5$$

$$T_2 = 2^2 + 3^2 = 13$$

$$T_3 = 3^2 + 4^2 = 25$$

$$T_4 = 4^2 + 5^2 = 41$$

- (a) Write down an expression in terms of n , for the n^{th} term T_n of the sequence.

Answer [1]

- (b) Explain why T_n is always odd.

Answer:

[1]

.....

.....

.....

.....

2. Simplify $\frac{a^2b}{2} \times (2a^0b^{-2})^3$, leaving your answer in positive index form.

Answer [2]

3. $x = \frac{4}{3}$ is a solution to the equation $18x^2 - kx - 20 = 0$, where k is a constant.

(a) Find the value of k .

Answer $k = \dots\dots\dots$ [1]

(b) Hence, find the other solution to the equation $18x^2 - kx - 20 = 0$.

Answer $\dots\dots\dots$ [1]

-
4. Given that the size of an exterior angle of a regular polygon is one-fifth its interior angle, find the number of sides of the polygon.

Answer $\dots\dots\dots$ [2]

5. Water is poured at a constant rate into each of the containers shown below.

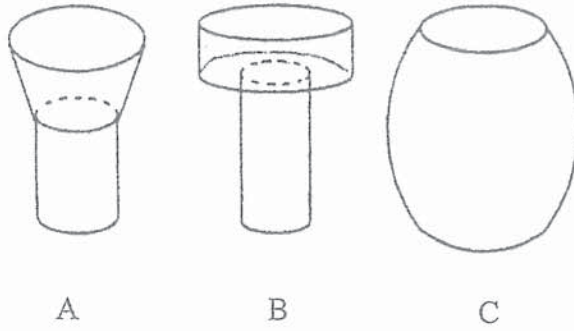

The graphs show the depth of water in the containers as they are being filled. Match the graphs with the appropriate container and complete the table below.

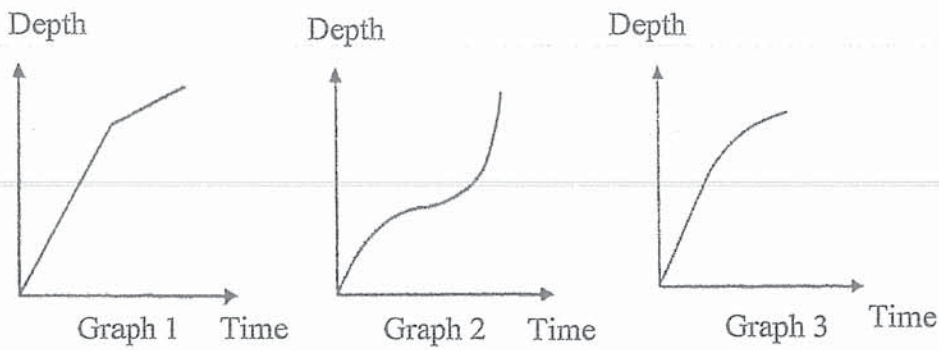

Answer:

[2]

Graph	Container
1	
2	
3	

6. (a) The graph below can be represented by the equation, $y = ax^n + b$. State the value of b , of n and the range of a .

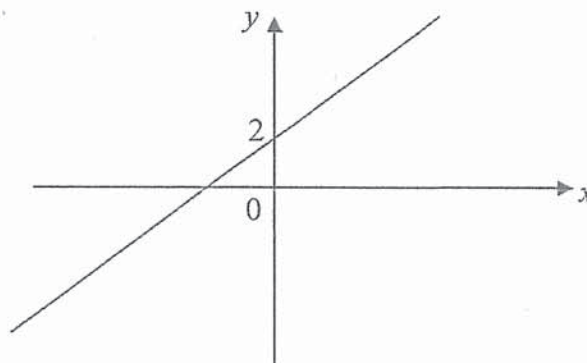

Answer $b = \dots\dots\dots n = \dots\dots\dots$ [1]

$\dots\dots\dots$ [1]

[Turn Over

- (b) On the axes in the answer space, sketch the graph of $y = ax^n$, where $a < 0$ and $n = 2$. [1]

Answer

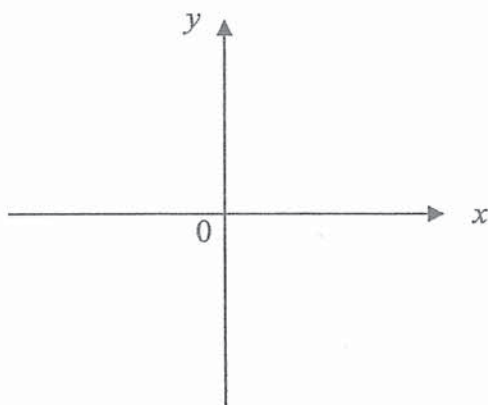

-
7. Find the largest prime number that satisfy the inequality $3 + y \leq 15 - 2y < y + 10$.

Answer [3]

8. Solve the simultaneous equations

$$8x + 3y = 4$$

$$4x = y + 4$$

Answer $x = \dots\dots\dots$ [3]

$y = \dots\dots\dots$

9. It is given that $\mathbf{p} = \begin{pmatrix} 6 \\ 5 \end{pmatrix}$, $\mathbf{q} = \begin{pmatrix} -4 \\ 3 \end{pmatrix}$ and $\mathbf{r} = \begin{pmatrix} 8 \\ -6 \end{pmatrix}$.

- (a) Find $|\mathbf{q} - 2\mathbf{p}|$.

Answer $\dots\dots\dots$ [2]

- (b) Use vectors to explain whether \mathbf{r} is parallel to \mathbf{q} .

Answer $\dots\dots\dots$ [1]

.....

10. Simplify and express $\frac{9m^2 - 12mn + 4n^2}{m^2 - n^2} \div \frac{3m - 2n}{m - n}$ as a single fraction.

Answer [3]

11. The ground area of a scale model is 1 : 100 of the actual ground area.

- (a) Given that the length of the model is 3 m, calculate the length of the house in metre.

Answerm [1]

- (b) Given that the actual volume of a storeroom in the house is 15 000 000 cm³, calculate the volume of the storeroom in the model in cm³.

Answercm³ [2]

12. A bag contains a total of 80 green, red and blue balls. There are 18 red balls in the bag.

- (a) If a ball is picked randomly, the probability of picking a green ball is $\frac{3}{8}$. How many blue balls are there?

Answer [1]

(b) Two balls are picked randomly from the bag. Find the probability of

- (i) picking a green ball and a red ball,

Answer [2]

- (ii) picking at least one red ball.

Answer [1]

13. Find the equation of the straight line
 (a) passing through the point $(-2, 5)$ and parallel to the y -axis,

Answer [1]

- (b) which passes through the point $(2, -5)$ and its gradient is the same as the line $y - 3x - 5 = 0$.

Answer [2]

14. In the diagram triangle ACD is right-angled, and B is on AC such that $\sin \angle ABD = \frac{x}{y}$.

Find in terms of x and y .

- (a) $\tan \angle BDC$,

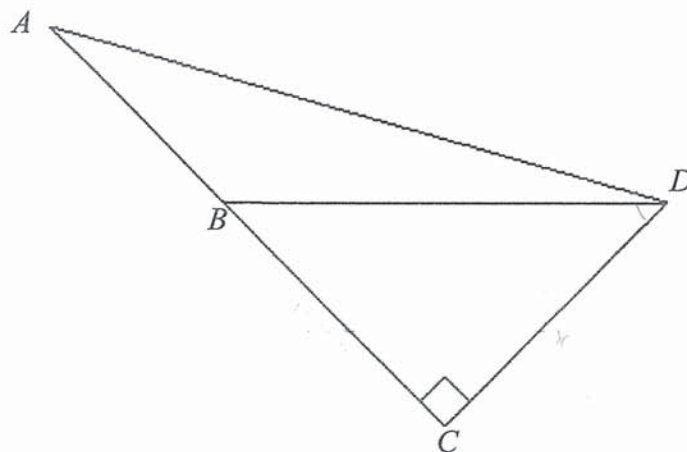

Answer [2]

- (b) $\cos \angle ABD$.

Answer [1]

15. (a) An insurance agent is paid a basic monthly salary of \$1200 and a commission of 8% on all the sales if the monthly sales made by the insurance agent exceed \$7500. The insurance agent's salary for a particular month was \$3694. Calculate the total sales made by the insurance agent.

Answer [2]

- (b) Two taps X and Y are turned on at the same time to fill up an empty tank. The rate at which Tap X fills up the tank per minute is twice as fast as that of Tap Y . When used together, both taps can fill the tank with 300 cm^3 of water in 5 minutes. Find the rate of flow of Tap Y in $\text{cm}^3/\text{minute}$.

Answer $\text{cm}^3/\text{minute}$ [2]

16. The table below shows the frequency of visits to the library by some students in Betta School in a week.

Number of visits	0	1	2	3	4
Number of students	3	5	4	x	2

- (a) If the mode is 3, write down the smallest possible value of x .

Answer $x = \dots\dots\dots$ [1]

- (b) If the median is 2, write down the largest possible value of x .

Answer $x = \dots\dots\dots$ [1]

- (c) Given that the mean is $2\frac{1}{22}$, calculate the value of x .

Answer $x = \dots\dots\dots$ [2]

17. The diagram shows a speed-time graph of a car. The total distance travelled in 35 s is 540 m.

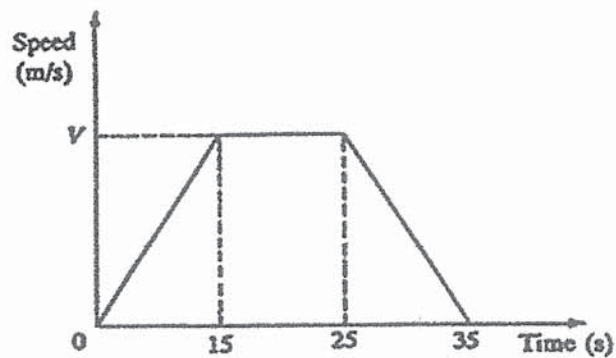

- (a) Calculate the maximum speed V m/s.

Answer $V = \dots\dots\dots$ m/s [2]

- (b) Calculate the speed of the car at 28 seconds.

Answer 16.8m/s [2]

18. The base areas of two geometrically similar pyramids are 98 cm^2 and 242 cm^2 .

- (a) Find the ratio of the height of the larger pyramid to the height of the smaller pyramid.

Answer:..... [1]

- (b) Given the total surface area of the smaller pyramid is 343 cm^2 . Find the total surface area of the larger pyramid.

Answer cm^2 [1]

- (c) Find the percentage difference in volumes of the two pyramids in terms of the larger pyramid.

Answer [2]

19. (a) s is directly proportional to the square of v . It is known that $s = 36$ for a particular value of v .

Find the value of s when this value of v is halved.

Answer $s =$ [2]

- (b) y is inversely proportional to x and $y = 4$ when $x = 6$. Find the value of y when $x = 9$.

Answer $y =$ [2]

20. Written as a product of its prime factors,

$$p = 3^x \times 5^y \times 7^3 \text{ and } q = 5 \times 7^2 \times 11$$

(a) Find the smallest value of x and of y for which p is a multiple of 35.

Answer $x = \dots\dots\dots y = \dots\dots\dots$ [2]

(b) Explain why $55q$ is a perfect square.

Answer: [1]

.....
.....
.....
.....

(c) Show your workings and state, with reason (s), if the product of p and q is an odd or even number.

Answer: [1]

.....
.....
.....
.....

21. (a) Describe the shaded region in set notation.

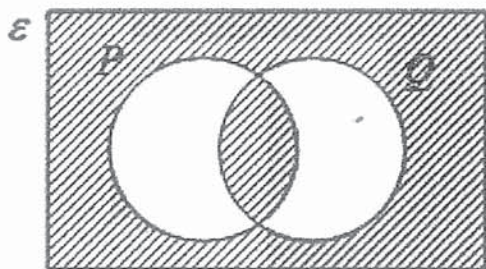

Answer [1]

- (b) Given that

$$\xi = \{x : x \text{ is a positive integer and } 0 < x < 10\}$$

$$A = \{x : x \text{ is a prime number}\}$$

$$B = \{x : x \text{ is a factor of } 12\}$$

$$C = \{x : \frac{50}{x} < 8\}$$

- (i) Find $B \cap C$.

Answer [1]

- (ii) List the elements of $(A \cup B)'$.

Answer [1]

- (ii) Draw a Venn diagram to illustrate the given information. [2]

Answer:

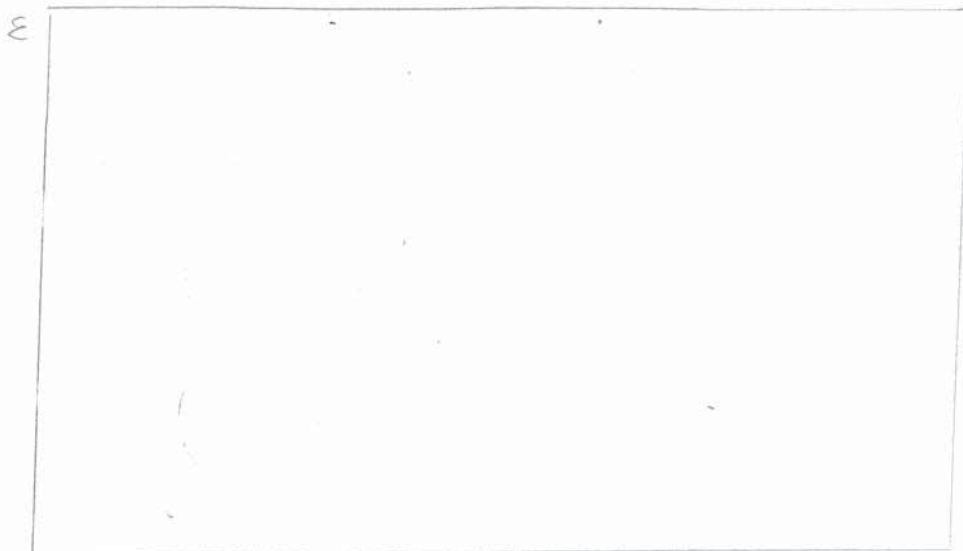

22. In triangle PQR , X is a point on QR such that $QX : XR$ is $3 : 2$ and RS is parallel to XY .

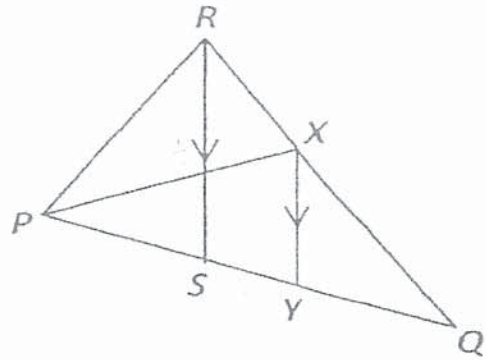

- (a) Show that triangle QXY is similar to triangle QRS .

Answer:

[2]

.....

.....

.....

.....

- (b) Given that the area of triangles QXY and PXR are 27 cm^2 and 46 cm^2 respectively. Find the area of

- (i) triangle QRS ,

Answer cm^2 [2]

- (ii) triangle PQR .

Answer cm^2 [2]

23.

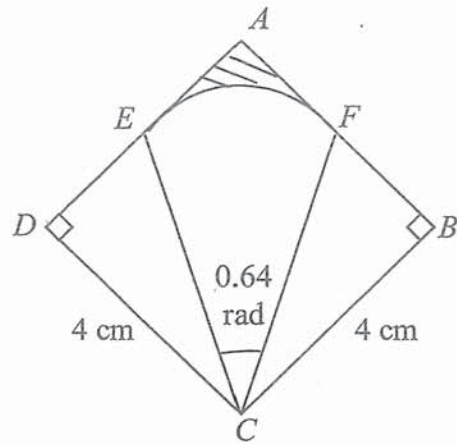

The sector CEF with centre at C is inscribed in the square $ABCD$ of side 4 cm .

Given that $AF = FB$, $DE = EA$ and angle $ECF = 0.64$ radian.

(a) Calculate the perimeter of the sector CEF .

Answer cm [3]

(b) Find the area of the shaded region.

Answer cm^2 [4]

End of Paper

Answer **all** the questions.

1 (a) Simplify $\left(\frac{64v^9}{t^{12}}\right)^{-\frac{1}{3}}$. [2]

(b) Express as a single fraction in its simplest form.

(i) $\frac{20x^2}{9} \div \frac{4xy^3}{15y}$. [1]

(ii) $\frac{4}{3x-1} - \frac{5}{2+x}$. [2]

(c) (i) Express $x^2 - 5x - 8$ in the form $(x + a)^2 + b$. [1]

(ii) Hence, solve the equation $x^2 - 5x - 8 = 0$, giving your answers correct to two decimal places. [3]

- 2 An ice-cream shop sells 4 different flavours of ice-cream. The table below shows the number of cups of ice-cream sold by the shop over 3 days.

	Chocolate	Vanilla	Strawberry	Durian
Friday	252	168	84	105
Saturday	305	158	115	152
Sunday	316	191	134	167

- (a) Represent the above information using a 3×4 matrix A .

[1]

- (b) The selling price of each cup of ice-cream is shown in the table below.

	Chocolate	Vanilla	Strawberry	Durian
Selling Price	\$2.10	\$1.80	\$2.05	\$2.55

Write down a matrix P such that the product AP represents the total sales of the ice-cream for each day respectively. Evaluate AP .

[2]

- (c) Evaluate $(1 \ 1 \ 1)A$ and state what the elements of the product represents. [2]

- (d) The cost price of each cup of ice-cream is shown in the table below.

	Chocolate	Vanilla	Strawberry	Durian
Cost Price	\$0.40	\$0.45	\$0.55	\$0.80

Write down two matrices such that the elements of their product represent the total profit received by the shop over the 3 days for the sale of each flavor of ice-cream respectively.

Evaluate this product.

[2]

- 3 (a) The diagram shows a toy which is made up of a cylindrical part and a hemispherical part.

The height of the cylindrical part is 4 cm and the radius of the hemispherical part is 6 cm.

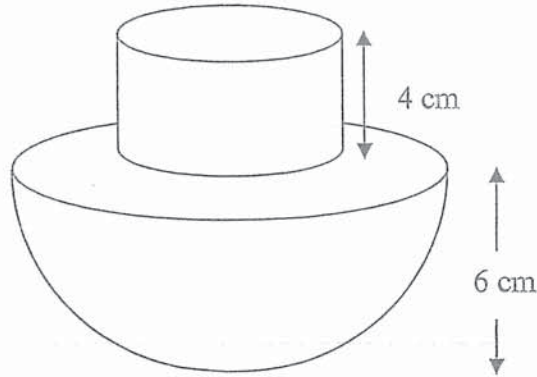

- (i) Find the radius of the cylindrical part, given that the volume of the cylindrical part is 150 cm^3 . [2]

- (ii) Calculate total surface area of the toy. [3]

- (b) In the diagram, A , B , C and D lie on a circle with centre O . Angle $AOC = 4x^\circ$.

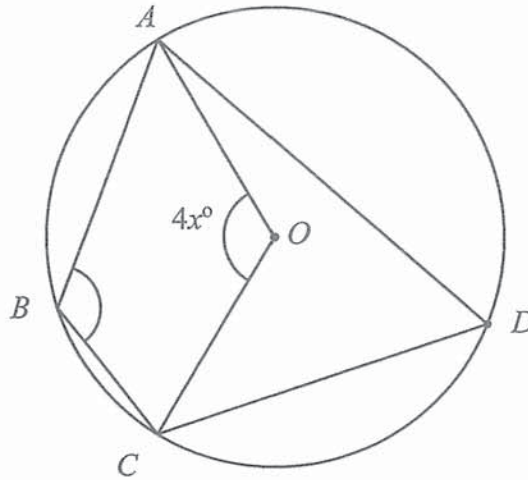

- (i) Find angle ADC , giving your answer in terms of x° . [2]

State a reason for your answer.

- (ii) Given further that angle $ABC = 5x^\circ + 12^\circ$, find the value of x . [2]

- 4 (a) Construct a triangle ABC such that $AB = 13$ cm, $AC = 12$ cm, angle $ABC = 55^\circ$, and angle ACB is acute.
The line AB has been drawn for you. [2]
- (b) Construct the angle bisector of angle BAC such that it intersects the line BC , and label the point of intersection D . [2]
- (c) Construct the perpendicular bisector of AD such that it intersects the line AC , and label the point of intersection E . Measure and write down the value of DE . [2]



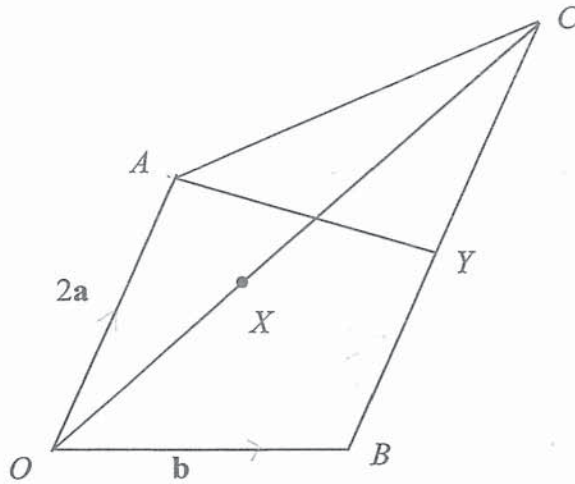

In the diagram, $\overline{OA} = 2\mathbf{a}$, $\overline{OB} = \mathbf{b}$. BC is parallel to OA and $BC = \frac{3}{2}OA$. X is a point on OC such that $OX = \frac{2}{3}XC$. Y is the midpoint of BC .

(a) Express in terms of \mathbf{a} and/or \mathbf{b} , as simply as possible,

(i) \overline{AB} , [1]

(ii) \overline{OC} , [1]

(iii) \overline{OX} , [1]

(iv) \overline{AX} . [1]

(b) What can you deduce about the points A , X and B ?
Justify your answer. [2]

(c) (i) AY produced meets OB produced at a point Z . Given that $\overline{AZ} = h\overline{AY}$, express \overline{AZ} in terms of a , b and h . [3]

(ii) Given also that $\overline{OZ} = k\overline{OB}$, express \overline{AZ} in terms of a , b , and k . [1]

(iii) Hence, show that $h = 4$ and $k = 4$. [2]

(d) Find the value of

(i) $\frac{\text{area of } \triangle OAX}{\text{area of } \triangle OAC}$, [1]

(ii) $\frac{\text{area of } \triangle OBX}{\text{area of } \triangle ABC}$. [1]

- 6 In the diagram, P and Q are the bases of two lighthouses such that P is located 40 km due north of Q .

A is a boat 30 km from P and on a bearing of 055° from P .

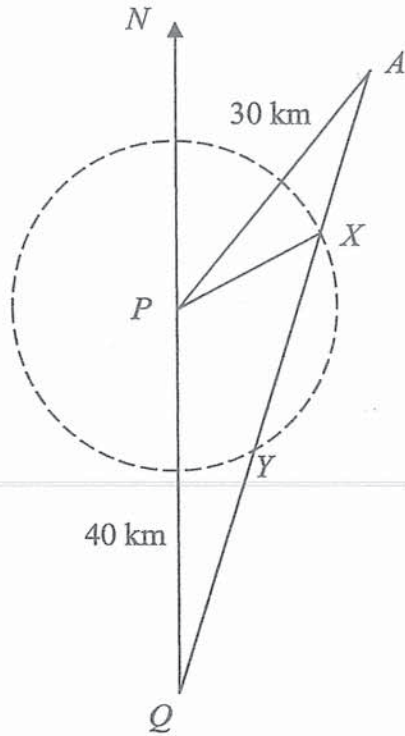

- (a) Find the distance AQ .

[3]

- (b) Find the bearing of A from Q .

[2]

Light from P can be seen within 20 km radius of P , beyond which the light becomes too faint to be seen. When the boat moves from A to Q , X and Y are the positions on the boat's journey which are 20 km from P .

(c) Calculate

(i) the shortest distance of the boat from P .

[2]

(ii) the **smallest** angle of elevation of the lighthouse P from the boat as it travels from X to Y , given that the height of lighthouse P is 600m.

[2]

- 7 The diagram shows two roads XY and YZ meeting at point Y . The roads are perpendicular to each other. $YX = 45$ km and $YZ = 25$ km.

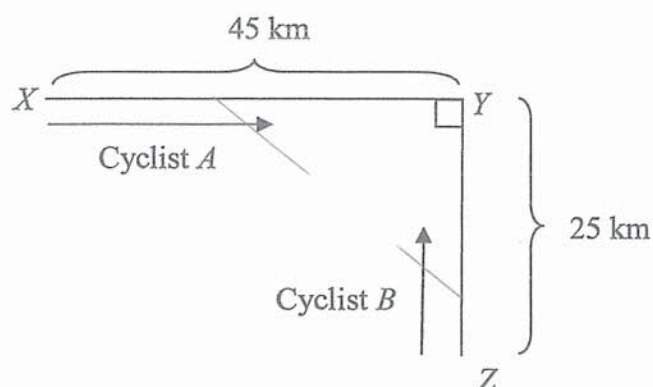

Cyclist A is travelling from point X towards point Y at a constant speed of 20 km/h.
Cyclist B is travelling from point Z towards point Y at a constant speed of 10 km/h.

- (a) Write down an expression, in terms of t , for the distance in kilometres

(i) between cyclist A and point Y , after t hours, [1]

(ii) between cyclist B and point Y , after t hours. [1]

- (b) Form an expression, in terms of t , for the shortest distance, d , between the two cyclists and show that it reduces to $\sqrt{500t^2 - 2300t + 2650}$.
Hence find the shortest distance between the two cyclists after 15 minutes. [4]

- (c) The two cyclists are 10 km apart at a certain instant, t hours.
Form a quadratic equation in terms of t and show that it reduces to
 $10t^2 - 46t + 51 = 0$.

[2]

- (d) Given that $t < 2$, find the time, in minutes, when the two cyclists are 10 km apart.
Correct your answer to 3 significant figures.

[3]

- 8 A scientist wanted to test the effect of different music on the growth of plants. 80 *Rosa chinensis* plants were exposed to Beethoven's Ninth Symphony, and their growth was observed over a period of 10 days. The cumulative frequency curve below shows the increase in the height of the plants at the end of 10 days.

Increase in heights of plants

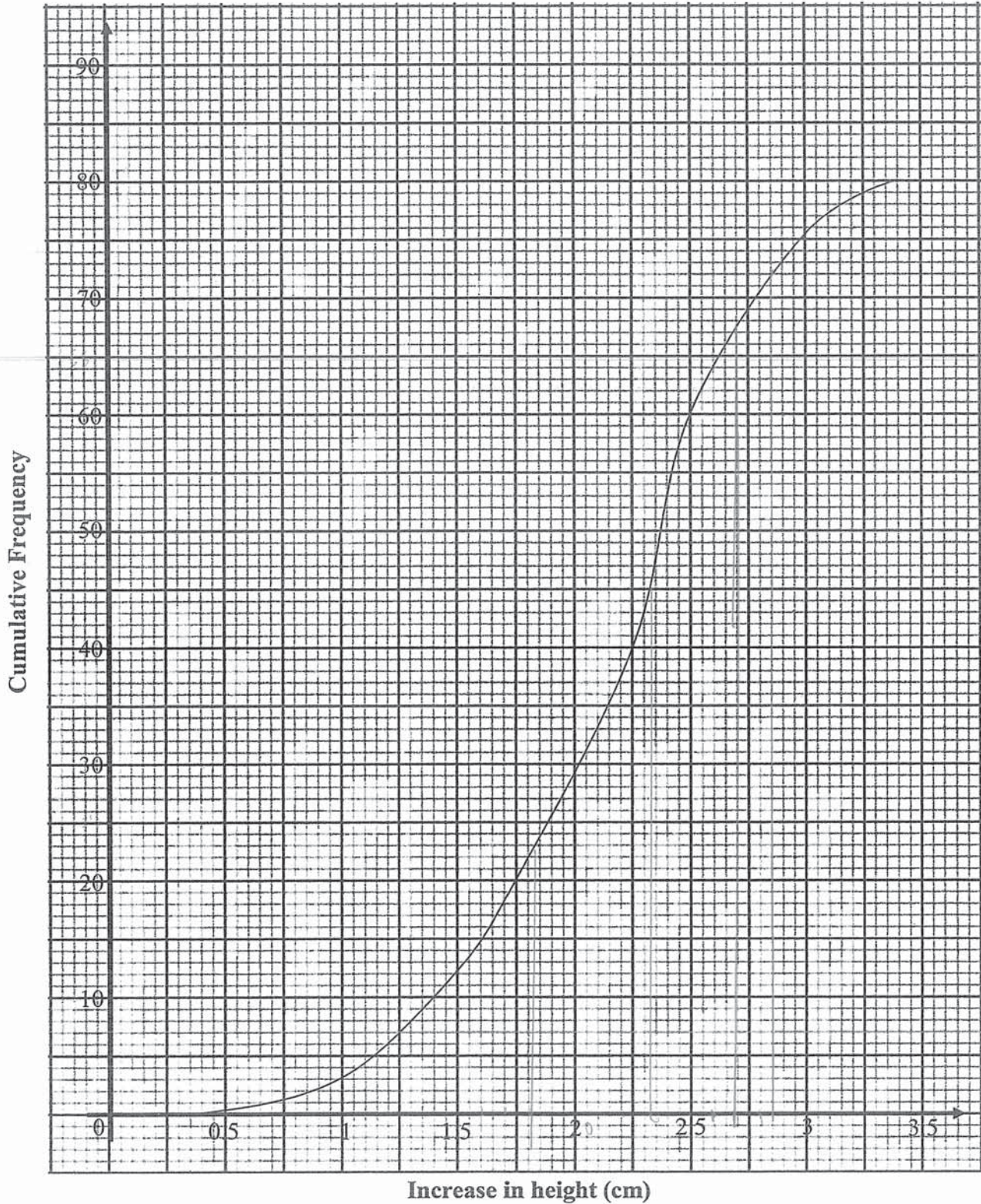

- (a) Find
- (i) the median increase in the height of the plants, [1]
- (ii) the interquartile range, [2]
- (iii) the 90th percentile. [2]
- (b) Another group of 80 *Rosa chinensis* plants were exposed to Bach's Goldberg Variations, and their growth were also observed over a period of 10 days. The box-and-whisker plot below shows the increase in the heights of the plants after 10 days.

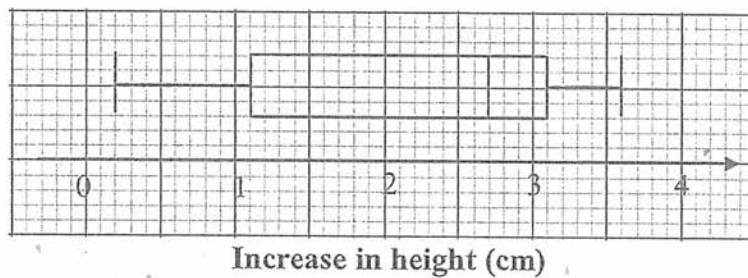

- (i) Describe how the cumulative frequency graph of the growth of the 80 plants exposed to Bach's Goldberg Variations will differ from that of those exposed to Beethoven's Ninth Symphony. [1]
- (ii) Make two comparisons between the growths of the plants under the two conditions. [2]

- 9 The variables x and y are connected by the equation $y = \frac{1}{2x^2} + 0.1x^2 - 3$. The table below shows some values of x and the corresponding values of y , correct to 2 decimal places.

x	0.5	1	1.5	2	3	4	5	6
y	-0.98	-2.40	-2.55	-2.48	-2.04	-1.37	p	0.61

- (a) Find the value of p . [1]

-0.48

- (b) In the space provided on the next page, using a scale of 2 cm to represent 1 unit on the horizontal axis and 2 cm to represent 0.5 units on the vertical axis, draw the graph of

$$y = \frac{1}{2x^2} + 0.1x^2 - 3 \text{ for } 0.5 \leq x \leq 6. \quad [3]$$

- (c) Using your graph, write down the solution(s) to the equation $\frac{1}{2x^2} + 0.1x^2 - 1.5 = 0$. [2]

- (d) By drawing a tangent, find the gradient of the curve at $x = 4$. [2]

- (e) By drawing a suitable straight line on the same axes, solve the equation

$$\frac{1}{2x^2} + 0.1x^2 - 0.5x = 0. \quad [3]$$

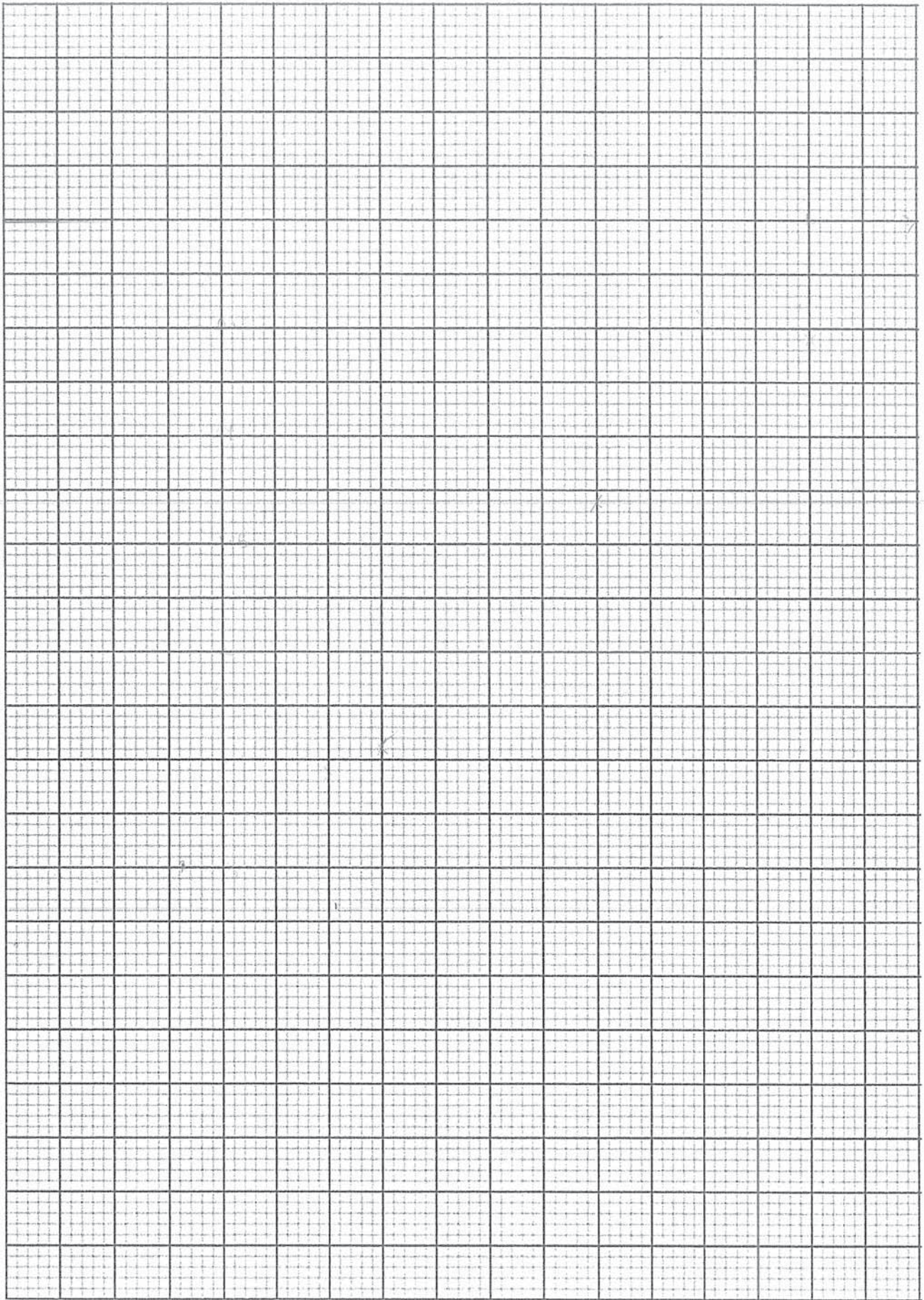

- 10 A right conical container of capacity $24\pi \text{ cm}^3$ and vertical angle 60° is completely filled with water. The height of the container is $h \text{ cm}$ and the base radius is $r \text{ cm}$.

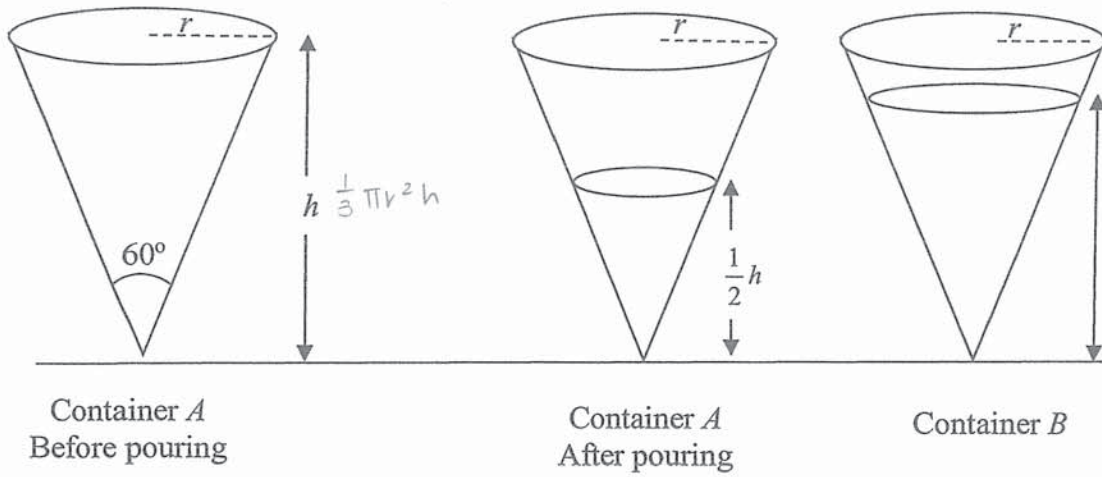

- (a) Find the value of r and of h .

[5]

The water in the container is poured into another identical container B so that the depth of water in container A is $\frac{1}{2}h$ cm.

(b) Find the volume of water in container B in terms of π .

[2]

- 11 A class of students plans to sell breakfast sets during the National Day carnival in order to raise funds for a charity.

Each breakfast set consists of 2 scrambled eggs, 2 slices of toast, 2 sausages, and a cup of coffee.

The students estimate that they will sell 250 breakfast sets.

Item	Description	Unit cost
Eggs	Pasar Fresh Eggs (10 per pack)	\$1.80
	Pasar Fresh Eggs (30 per pack)	\$4.35
Bread	Sunshine Enriched Soft White Bread (14 slices)	\$1.80
	FairPrice Wholemeal Bread (12 slices)	\$1.55
Sausages	Tierney's Chicken Hot Dog (10 per pack)	\$5.25
	FairPrice Sausages (6 per pack) (\$0.35 off per 2 packs)	\$3.20
Coffee	Nescafe 3 in 1 Instant Coffee (35 per pack) (Buy 5 get 1 free)	\$6.15
	Gold Roast 3 in 1 Coffeemix (25 per pack)	\$3.95

- (a) Find the lowest possible total cost of the ingredients for the breakfast sets. [5]

- (b) The school provides \$200 in funding for the students, and up to 30% of the sales can be used to cover for their expenses, while the remaining goes to the charity. The students also wish to raise at least \$600 for charity. Find the minimum they must charge for each breakfast set (to the nearest ten cents). Justify your answer, showing all necessary workings clearly. State an assumption you have made in your calculations. [4]

End of Paper

1a	$n^2 + (n+1)^2$ or $2n^2 + 2n + 1$	B1								
1b	For any two consecutive numbers, one would be even and the other one odd. Since the square of an even number is even and the square of an odd number is odd, one of the squares of the two consecutive numbers will be even, and the other will be odd. Hence, their sum will be odd.	B1								
2	$\frac{a^2b}{2} \times (2a^0b^{-2})^3 = \frac{a^2b}{2} \times 8b^{-6}$ $= \frac{4a^2}{b^5}$	M1 A1								
3a	$18\left(\frac{4}{3}\right)^2 - k\left(\frac{4}{3}\right) - 20 = 0$ $k = 9$	[B1]								
3b	$18x^2 - 9x - 20 = 0$ $(3x-4)(6x+5) = 0$ $x = \frac{4}{3}$ or $x = -\frac{5}{6}$ (the other solution)	[B1]								
4	$x + 5x = 180$ $x = 30$ $\frac{360}{30} = 12$ Number of sides = 12	M1 A1								
5	<table border="1"> <thead> <tr> <th>Graph</th> <th>Container</th> </tr> </thead> <tbody> <tr> <td>1</td> <td>B</td> </tr> <tr> <td>2</td> <td>C</td> </tr> <tr> <td>3</td> <td>A</td> </tr> </tbody> </table>	Graph	Container	1	B	2	C	3	A	B1 - 1 correct B2 - All correct
Graph	Container									
1	B									
2	C									
3	A									
6a	$b = 2$ $n = 1$ Range of a : $a > 0$	B1 for both answers correct B1								

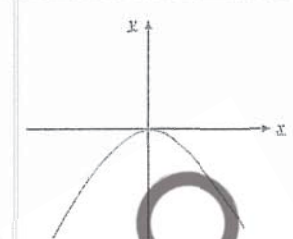
6b		B1
7	$3 + y \leq 15 - 2y$ and $15 - 2y < y + 10$ $3y \leq 12$ $5 < 3y$ $y \leq 4$ $y > \frac{5}{3}$	M1 for each correct answer
8	<p>Largest prime number is 3.</p> $8x + 3y = 4$ ----- (1) $4x = y + 4$ ----- (2) From (2), $y = 4x - 4$ ----- (3) Sub (3) in (1), $8x + 3(4x - 4) = 4$ $20x = 16$ $x = \frac{4}{5}$ $y = 4 \times \frac{4}{5} - 4$ $= -\frac{4}{5}$	A1
9a	$ q - 2p $ $= \begin{vmatrix} -4 \\ 3 \end{vmatrix} - 2 \begin{vmatrix} 6 \\ 5 \end{vmatrix}$ $= \begin{vmatrix} -4 \\ 3 \end{vmatrix} - \begin{vmatrix} 12 \\ 10 \end{vmatrix}$ $= \begin{vmatrix} -16 \\ -7 \end{vmatrix}$ $= \sqrt{(-16)^2 + (-7)^2}$ $= \sqrt{305}$ $= 17.464$ units (5 s.f.) $= 17.5$ units (3 s.f.)	M1 A1

9b	If r is parallel to q, $r = kq$ Now, $\begin{pmatrix} 8 \\ -6 \end{pmatrix} = -2 \begin{pmatrix} -4 \\ 3 \end{pmatrix}$, i.e. $r = -2q$ or $q = -\frac{1}{2}r$ Hence, r is parallel to q.	B1
10	$\frac{9m^2 - 12mn + 4n^2}{m^2 - n^2} \div \frac{3m - 2n}{m - n}$ $= \frac{(3m - 2n)(3m - 2n)}{(m - n)(m + n)} \div \frac{3m - 2n}{m - n}$ $= \frac{(3m - 2n)(3m - 2n)}{(m - n)(m + n)} \times \frac{m - n}{3m - 2n}$ $= \frac{3m - 2n}{m + n}$	M1 – correct factorisation M1 – for changing divide to multiplication and interchange the numerator with the denominator of the second fraction. A1
11a	<u>Area Scale</u> 1 : 100 <u>Linear Scale</u> 1 : 10 Length of the house = 3×10 = 30 m	B1
11b	Volume of the model = $\left(\frac{1}{10}\right)^3 \times 15000000$ = 15000 cm^3	M1 A1
12a	$\frac{3}{8} = \frac{30}{80}$ $80 - 30 - 18 = 32$	M1 A1
12bi	$\frac{30}{80} \times \frac{18}{79} + \frac{18}{80} \times \frac{30}{79}$ $= \frac{27}{158}$	M1 A1
12bii	P(at least 1 red ball) = $1 - \text{P(no red ball)}$ $1 - \left(\frac{62}{80}\right)\left(\frac{61}{79}\right)$ $= \frac{1269}{3160}$ OR	B1

	P(at least 1 red ball) = $1 - \text{P(GG)} - \text{P(GB)} - \text{P(BG)} - \text{P(BB)}$ $1 - \left(\frac{30}{80}\right)\left(\frac{29}{79}\right) - \left(\frac{30}{80}\right)\left(\frac{32}{79}\right) - \left(\frac{32}{80}\right)\left(\frac{30}{79}\right) - \left(\frac{32}{80}\right)\left(\frac{31}{79}\right)$ $= \frac{1269}{3160}$ OR P(at least 1 red ball) = $\text{P(GR)} + \text{P(RG)} + \text{P(RR)} + \text{P(RB)} + \text{P(BR)}$ $\left(\frac{30}{80}\right)\left(\frac{18}{79}\right) + \left(\frac{18}{80}\right)\left(\frac{30}{79}\right) + \left(\frac{18}{80}\right)\left(\frac{17}{79}\right) + \left(\frac{18}{80}\right)\left(\frac{32}{79}\right)$ $= \frac{1269}{3160}$	
13a	$x = -2$	B1
13b	$y = 3x + c$ Sub (2, -5), $-5 = 3(2) + c$ $c = -11$ $y = 3x - 11$	M1 A1
14a	$BC = \sqrt{y^2 - x^2}$ $\tan \angle BDC = \frac{\sqrt{y^2 - x^2}}{x}$	M1 A1
14b	$\cos \angle ABD = -\cos \angle DBC = -\frac{\sqrt{y^2 - x^2}}{y}$	B1
15a	Total sales = $(3694 - 1200) \times \frac{100}{8}$ = \$31175	M1 A1
15b	Tap X: $2r \text{ cm}^3/\text{min}$ Tap Y: $r \text{ cm}^3/\text{min}$ In 5 min, $5(2r) + 5r = 300$ $r = 20$ Rate of Tap Y = $20 \text{ cm}^3/\text{min}$ OR	M1 A1

	$V_x: V_y: 2:1$ Volume of water in 5 min = $\frac{300}{3}$ $= 100 \text{ cm}^3$ Rate = $\frac{100}{5}$ $= 20 \text{ cm}^3/\text{min}$	M1 A1
16a	6	B1
16b	$3+5+4-1 = x+2$ $x = 9$	B1
16c	$\frac{3(0)+5(1)+4(2)+3x+2(4)}{14+x} = 2\frac{1}{22}$ $\frac{21+3x}{14+x} = \frac{45}{22}$ $462+66x = 630+45x$ $21x = 168$ $x = 8$	M1 A1
17a	$\text{Total dist} = \frac{1}{2}v(10+35)$ $540 = 22.5v$ $v = 24 \text{ m/s}$	M1 A1
17b	$a = \frac{24}{10}$ $= 2.4 \text{ m/s}^2$ $\text{Speed} = 24 - 3(2.4)$ $= 16.8 \text{ m/s}$	M1 A1
18a	$\frac{H_L}{H_S} = \sqrt{\frac{242}{98}}$ $= \frac{11}{7}$	B1
18b	$\frac{A_S}{A_L} = \left(\frac{7}{11}\right)^2$ $\frac{343}{A_L} = \frac{49}{121}$ $A_L = \frac{121}{49} \times 343$ $A_L = 847 \text{ cm}^2$	B1

18c	$\frac{V_S}{V_L} = \left(\frac{7}{11}\right)^3$ $\frac{V_S}{V_L} = \frac{343}{1331}$ $\% \text{ difference} = \frac{1331-343}{1331} \times 100\%$ $= 74.229\% (5 \text{ s.f.})$ $= 74.2\% (3 \text{ s.f.})$	M1 A1
-----	---	----------

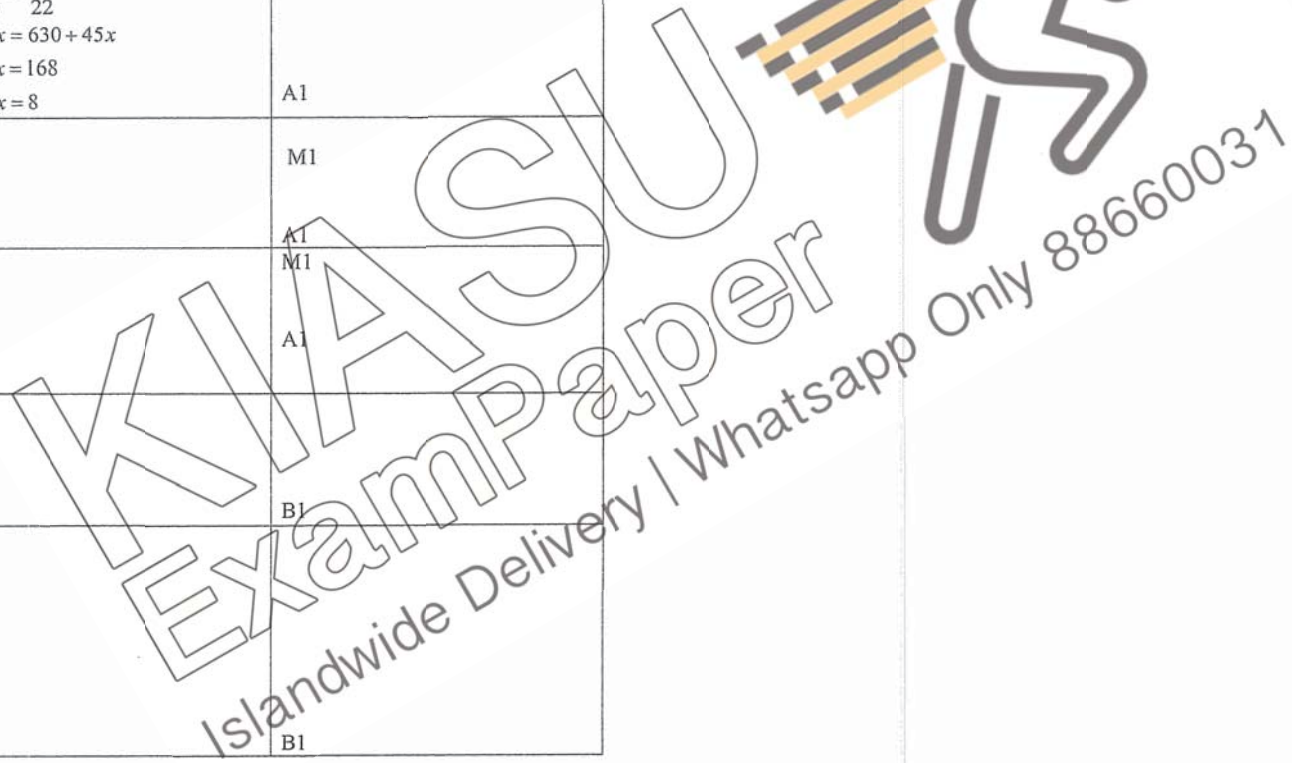

19a	$s = kv^2$ $36 = kv^2$ $s = k\left(\frac{v}{2}\right)^2$ $s = 9$	M1 A1
19b	$y = \frac{k}{x}$ $k = 24$ $y = \frac{24}{9}$ $y = 2\frac{2}{3}$	M1 A1
20a	$35 = 5 \times 7$ $3^x \times 5^y \times 7^3$ needs to have a factor of 5 and 7. Therefore, $x = 0, y = 1$	B1 – if 1 correct B2 – If 2 correct
20b	$55q$ $= 5 \times 11 \times q$ $= 5 \times 11 \times 5 \times 7^2 \times 11$ $= 5^2 \times 7^2 \times 11^2$ Since the indices of the prime factors are multiples of 2, $55q$ is a perfect square.	B1
20c	$p \times q = 3^x \times 5^y \times 7^3 \times 5 \times 7^2 \times 11$ $= 3^x \times 5^{y+1} \times 7^5 \times 11$ Since $p \times q$ is a product of prime factors that are odd, $p \times q$ is an odd number.	B1
21a	$(P \cup Q)' \cup (P \cap Q)$ or $(P' \cap Q') \cup (P \cap Q)$	B1
21bi	$B \cap C = \emptyset$ or $\{ \}$	B1
21bii	$(A \cup B)' = \{8, 9\}$	B1

21biii		B1 – 5 out of 9 correct B2 – All correct
22a	$\angle QXY = \angle QRS$ (corr. \angle s, $XY \parallel RS$) $\angle QYX = \angle QSR$ (corr. \angle s, $XY \parallel RS$) $\angle ROS = \angle XOY$ (common \angle s) $\triangle OXY$ is similar to $\triangle ORS$. (A1)	B1- Either 2 of these reasons
22bi	Since $\triangle OXY$ is similar to $\triangle ORS$, $\frac{\text{Area of } \triangle ORS}{\text{Area of } \triangle OXY} = \left(\frac{1}{3}\right)^2 = \frac{25}{9}$ $\text{Area of } \triangle ORS = \frac{25}{9} \times 27 = 75 \text{ cm}^2$	A1 M1, A1
22ii	Consider $\triangle PQR$ and $\triangle PXR$: $\frac{\text{Area of } \triangle PQR}{\text{Area of } \triangle PXR} = \frac{\frac{1}{2} \times QR \times h}{\frac{1}{2} \times XR \times h} = \frac{QR}{XR} = \frac{5}{2}$ $\text{Area of } \triangle PQR = \frac{5}{2} \times 46 = 115 \text{ cm}^2$	M1, A1

23a	$EC = \sqrt{4^2 + 2^2}$ $= \sqrt{20}$ <p>Perimeter of sector CEF</p> $= 2\sqrt{20} + \sqrt{20}(0.64)$ $\approx 11.8 \text{ cm}$	<p>M1</p> <p>M1</p> <p>A1</p>
23b	<p>Area of sector CEF</p> $= \frac{1}{2}(\sqrt{20})^2(0.64)$ $= 6.4 \text{ cm}^2$ <p>Area of shaded region</p> $= 4^2 - 2\left(\frac{1}{2} \times 4 \times 2\right) - 6.4$ $= 1.6 \text{ cm}^2$	<p>M1</p> <p>A1</p> <p>M1</p> <p>A1</p>



KIASU
ExamPaper
Islandwide Delivery | Whatsapp Only 88660031

Answer Key

1(a)	$\frac{t^4}{4v^3}$
1(b)(i)	$\frac{25x}{3y^2}$
1(b)(ii)	$\frac{13-11x}{(3x-1)(2+x)}$
1(c)(i)	$\left(x - \frac{5}{2}\right)^2 - \frac{57}{4}$
1(c)(ii)	$x = 6.27$ or -1.27
2(a)	$A = \begin{pmatrix} 252 & 168 & 84 & 105 \\ 305 & 158 & 115 & 152 \\ 316 & 191 & 134 & 167 \end{pmatrix}$
2(b)	$P = \begin{pmatrix} 2.10 \\ 1.80 \\ 2.05 \\ 2.55 \end{pmatrix}$ $AP = \begin{pmatrix} 1271.55 \\ 1548.25 \\ 1707.95 \end{pmatrix}$
2(c)	The elements represents the total number of cups of ice-cream sold over the 3 days of each flavor respectively.
2(d)	$(1484.10 \quad 697.95 \quad 499.50 \quad 742)$
3(a)(i)	$r = 3.45 \text{ cm}$
3(a)(ii)	426 cm^2
3(b)(i)	$2x^\circ$
3(b)(ii)	$x^\circ = 24^\circ$
4(c)	6.3 cm
5(a)(i)	$b - 2a$
5(a)(ii)	$b + 3a$
5(a)(iii)	$\frac{2}{5}(b + 3a)$
5(a)(iv)	$-\frac{4}{5}a + \frac{2}{5}b$
5(b)	$\overline{AB} = \frac{5}{2}\overline{AX}$ $A, X, \text{ and } B \text{ are collinear.}$
5(c)(i)	$\overline{AZ} = hb - \frac{1}{2}ha$
5(c)(ii)	$\overline{AZ} = -2a + kb$
5(c)(iii)	(AG)

5(d)(i)	$\frac{2}{5}$
5(d)(ii)	$\frac{2}{5}$
6(a)	62.3 km
6(b)	023.2°
6(c)	15.8 km
6(d)	1.7°
7(a)(i)	$(45 - 20t)$ km
7(a)(ii)	$(25 - 10t)$ km
7(b)	45.9 km
7(c)	(AG)
7(d)	112 minutes
8(a)(i)	2.25 cm
8(a)(ii)	0.75 cm
8(a)(iii)	2.85 cm
8(b)(i)	<p>The cumulative frequency graph of the growth of plants exposed to Bach will be less steep in the middle/steeper at the upper quartile/wider range/broader range compared to that of plants exposed to Beethoven.</p> <p>OR</p> <p>The middle of the cumulative frequency graph of the growth of plants exposed to Bach is shifted to the right compared to that of plants exposed to Beethoven.</p>
8(b)(ii)	<p>The plants grow better when exposed to Bach on average compared to when exposed to Beethoven as the median increase in heights of the plants when exposed to Bach is higher than those exposed to Beethoven.</p> <p>The increase in heights of the plants are more spread when exposed to Bach than when exposed to Beethoven as the interquartile range is larger when exposed to Bach than when exposed to Beethoven.</p>
9(a)	-0.48
9(b)	<i>(graph)</i>
9(c)	0.6 or 3.8
9(d)	0.792
9(e)	1.1 or 4.95
10(a)	$h = 6$ cm $r = 3.46$ cm
10(b)	21π
11(a)	\$428.65
11(b)	Any value above \$3.3146 Assume no cost incurred for cooking. (or any reasonable)



BEATTY SECONDARY SCHOOL
PRELIMINARY EXAMINATION 2019

MARKING SCHEME

SUBJECT : Mathematics LEVEL : Sec 4 Express
PAPER : 4048 / 02 Sec 5 Normal (Academic)
DURATION : 2 hours 30 minutes
SETTER : Mr Teo CK DATE : 29 August 2019
Miss Chong HY

CLASS :	NAME :	REG NO :
---------	--------	----------

READ THESE INSTRUCTIONS FIRST

Write your name, class and index number in the spaces on the top of this page.
Write in dark blue or black pen.
You may use a pencil for any diagrams or graphs.
Do not use staples, paper clips, highlighters, glue or correction fluid.

Answer all questions.

If working is needed for any question, it must be shown with the answer.
Omission of essential working will result in loss of marks.
Calculators should be used where appropriate.

If the degree of accuracy is not specified in the question, and if the answer is not exact, give the answer to three significant figures. Give answers in degrees to one decimal place.

For π , use either your calculator value or 3.142, unless the question requires the answer in terms of π .

At the end of the examination, fasten all your work securely together.
The number of marks is given in brackets [] at the end of each question or part question.
The total number of marks for this paper is 100.

This paper consists of 23 printed pages (including this cover page)

[Turn over

Mathematical Formulae

Compound Interest

$$\text{Total amount} = P(1 + \frac{r}{100})^n$$

Mensuration

Curved surface area of a cone = πrl

Surface area of a sphere = $4\pi r^2$

Volume of a cone = $\frac{1}{3}\pi r^2 h$

Volume of a sphere = $\frac{4}{3}\pi r^3$

Area of triangle ABC = $\frac{1}{2}ab \sin C$

Arc length = $r\theta$, where θ is in radians

Sector area = $\frac{1}{2}r^2\theta$, where θ is in radians

Trigonometry

$$\frac{a}{\sin A} = \frac{b}{\sin B} = \frac{c}{\sin C}$$

$$a^2 = b^2 + c^2 - 2bc \cos A$$

Statistics

$$\text{Mean} = \frac{\sum fx}{\sum f}$$

$$\text{Standard Deviation} = \sqrt{\frac{\sum fx^2}{\sum f} - \left(\frac{\sum fx}{\sum f}\right)^2}$$

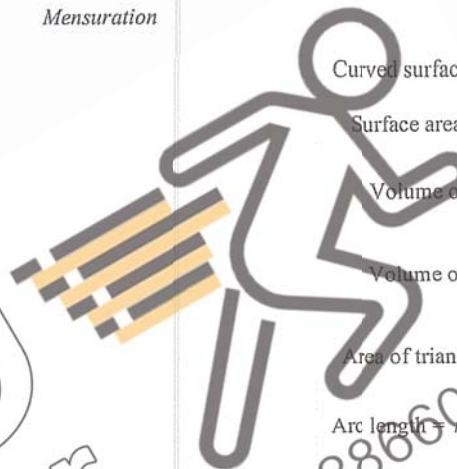

WASU Exam Paper
Islandwide Delivery | Whatsapp Only 88660031

Answer all the questions.

1 (a) Simplify $\left(\frac{64v^9}{t^{12}}\right)^{\frac{1}{3}}$.

[2]

$$\begin{aligned} & \left(\frac{64v^9}{t^{12}}\right)^{\frac{1}{3}} \\ &= \left(\frac{t^{12}}{64v^9}\right)^{\frac{1}{3}} \text{---M1} \\ &= \frac{t^4}{4v^3} \text{---A1} \end{aligned}$$

(b) Express as a single fraction in its simplest form.

(i) $\frac{20x^2}{9} \div \frac{4xy^3}{15y}$.

[1]

$$\begin{aligned} & \frac{20x^2}{9} \div \frac{4xy^3}{15y} \\ &= \frac{20x^2}{9} \times \frac{15y}{4xy^3} \\ &= \frac{25x}{3y^2} \text{---B1} \end{aligned}$$

(ii) $\frac{4}{3x-1} - \frac{5}{2+x}$.

[2]

$$\begin{aligned} & \frac{4}{3x-1} - \frac{5}{2+x} \\ &= \frac{4(2+x) - 5(3x-1)}{(3x-1)(2+x)} \text{---M1} \\ &= \frac{13-11x}{(3x-1)(2+x)} \text{---A1} \end{aligned}$$

(c) (i) Express $x^2 - 5x - 8$ in the form $(x+a)^2 + b$.

[1]

$$\begin{aligned} & x^2 - 5x - 8 \\ &= \left(x - \frac{5}{2}\right)^2 - \left(\frac{5}{2}\right)^2 - 8 \\ &= \left(x - \frac{5}{2}\right)^2 - \frac{57}{4} \text{---B1} \end{aligned}$$

(ii) Hence, solve the equation $x^2 - 5x - 8 = 0$, giving your answers correct to two decimal places.

[3]

$$\begin{aligned} & x^2 - 5x - 8 = 0 \\ & \left(x - \frac{5}{2}\right)^2 - \frac{57}{4} = 0 \\ & \left(x - \frac{5}{2}\right)^2 = \frac{57}{4} \text{---M1 (ECF their (ci))} \\ & x - \frac{5}{2} = \pm \sqrt{\frac{57}{4}} \\ & x = 6.27 \text{ or } -1.27 \text{---A2} \end{aligned}$$

- 2 An ice-cream shop sells 4 different flavours of ice-cream. The table below shows the number of cups of ice-cream sold by the shop over 3 days.

	Chocolate	Vanilla	Strawberry	Durian
Friday	252	168	84	105
Saturday	305	158	115	152
Sunday	316	191	134	167

- (a) Represent the above information using a 3×4 matrix A.

[1]

$$A = \begin{pmatrix} 252 & 168 & 84 & 105 \\ 305 & 158 & 115 & 152 \\ 316 & 191 & 134 & 167 \end{pmatrix} \quad \text{--- B1}$$

- (b) The selling price of each cup of ice-cream is shown in the table below.

	Chocolate	Vanilla	Strawberry	Durian
Selling Price	\$2.10	\$1.80	\$2.05	\$2.55

Write down a matrix P such that the product AP represents the total sales of all the ice-cream for each day respectively. Evaluate AP.

[2]

$$P = \begin{pmatrix} 2.10 \\ 1.80 \\ 2.05 \\ 2.55 \end{pmatrix} \quad \text{--- B1}$$

$$AP = \begin{pmatrix} 252 & 168 & 84 & 105 \\ 305 & 158 & 115 & 152 \\ 316 & 191 & 134 & 167 \end{pmatrix} \begin{pmatrix} 2.10 \\ 1.80 \\ 2.05 \\ 2.55 \end{pmatrix}$$

$$= \begin{pmatrix} 1271.55 \\ 1548.25 \\ 1707.95 \end{pmatrix} \quad \text{--- B1}$$

(for P given as row matrix, B0)

- (c) Evaluate $(1 \ 1 \ 1)A$ and state what the elements of the product represents.

[2]

$$(1 \ 1 \ 1) \begin{pmatrix} 252 & 168 & 84 & 105 \\ 305 & 158 & 115 & 152 \\ 316 & 191 & 134 & 167 \end{pmatrix} = (873 \ 517 \ 333 \ 424) \quad \text{--- B1}$$

The elements represents the total number of cups of ice-cream sold over the 3 days of each flavor respectively. --- B1

- (d) The cost price of each cup of ice-cream is shown in the table below.

	Chocolate	Vanilla	Strawberry	Durian
Cost Price	\$0.40	\$0.45	\$0.55	\$0.80

Write down two matrices such that the elements of their product represent the total profit received by the shop over the 3 days for the sale of each flavor of ice-cream respectively.

Evaluate this product.

[2]

$$(873 \ 517 \ 333 \ 424) \begin{pmatrix} 1.70 & 0 & 0 & 0 \\ 0 & 1.35 & 0 & 0 \\ 0 & 0 & 1.50 & 0 \\ 0 & 0 & 0 & 1.75 \end{pmatrix} \quad \text{--- M1 for correct } 4 \times 4 \text{ matrix}$$

$$= (1484.10 \ 697.95 \ 499.50 \ 742) \quad \text{--- A1}$$

- 3 (a) The diagram shows a toy which is made up of a cylindrical part and a hemispherical part.
The height of the cylindrical part is 4 cm and the radius of the hemispherical part is 6 cm.

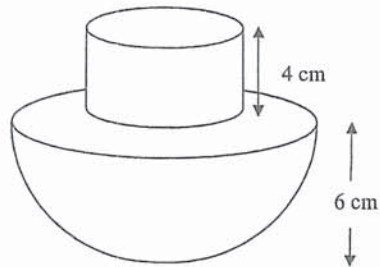

- (i) Find the radius of the cylindrical part, given that the volume of the cylindrical part is 150 cm^3 . [2]

$$\begin{aligned} \pi \times r^2 \times 4 &= 150 \text{ ---- M1} \\ r^2 &= \frac{150}{\pi \times 4} \\ r &= 3.4549... \\ r &= 3.45 \text{ cm (3sf) ---- A1} \end{aligned}$$

- (ii) Calculate total surface area of the toy. [3]

$$\begin{aligned} SA \text{ of hemisphere} &= 2 \times \pi \times 6^2 + \pi \times 6^2 = 108\pi \text{ ---- M1 (ECF their (i))} \\ \text{Total SA} &= 108\pi + 2 \times \pi \times 3.4549... \times 4 \text{ ---- M1 (ECF their (i))} \\ &= 426.178... = 426 \text{ cm}^2 \text{ ---- A1} \end{aligned}$$

OR

$$\begin{aligned} SA \text{ of hemisphere} &= 3\pi(6)^2 = 108\pi \text{ --- M1} \\ SA \text{ of cylinder} &= \pi(3.4549)^2 + 2\pi(3.4549)(4) = 39.575\pi \text{ --- M1} \\ TSA &= 108\pi + 39.575\pi - \pi(3.4549)^2 = 426 \text{ cm}^2 \text{ --- A1} \end{aligned}$$

- (b) In the diagram, A, B, C and D lie on a circle with centre O . Angle $AOC = 4x^\circ$.

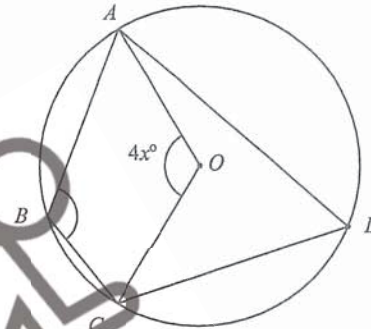

- (i) Find angle ADC , giving your answer in terms of x° . [2]

State a reason for your answer.

$$\text{angle } ADC = 2x^\circ \text{ (angle at centre} = 2 \text{ angle at circumference) ---- B2}$$

- (ii) Given further that angle $ABC = 5x^\circ + 12^\circ$, find the value of x . [2]

$$\begin{aligned} 5x^\circ + 12^\circ &= 180^\circ - 2x^\circ \text{ ---- M1} \\ 7x^\circ &= 168^\circ \\ x^\circ &= 24^\circ \text{ ---- A1} \end{aligned}$$

OR

$$\begin{aligned} 2(5x + 12) &= 360 - 4x \text{ --- M1} \\ 10x + 24 &= 360 - 4x \\ 14x &= 336 \\ x &= 24 \text{ --- A1} \end{aligned}$$

- 4 (a) Construct a triangle ABC such that $AB = 13$ cm, $AC = 12$ cm, angle $ABC = 55^\circ$, and angle ACB is acute. The line AB has been drawn for you. [2]
- (b) Construct the angle bisector of angle BAC such that it intersects the line BC , and label the point of intersection D . [2]
- (c) Construct the perpendicular bisector of AD such that it intersects the line AC , and label the point of intersection E . Measure and write down the value of DE . [2]

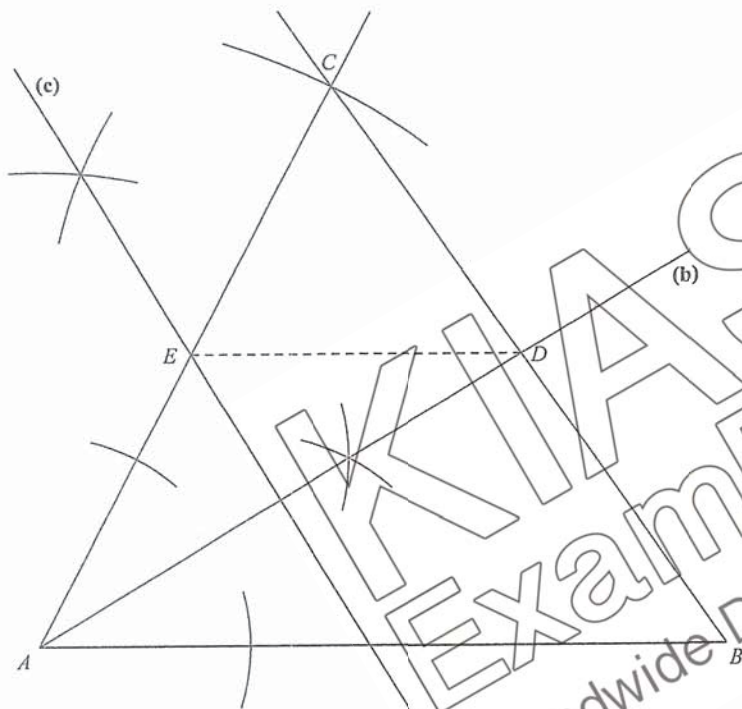

- (a) Correct triangle --- B1
Arcs seen --- B1
- (b) Correct bisector with arcs --- B1
Correct label --- B1
- (c) Correct bisector with arcs --- B1
Correct label and measurement --- B1

(c) 6.3 cm (± 0.1)
(actual = 6.24 cm)

No question labels = minus 1 overall

5

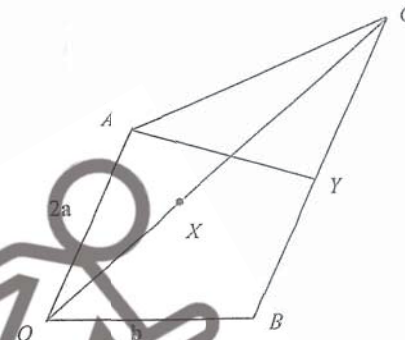

In the diagram, $\vec{OA} = 2a$, $\vec{OB} = b$. BC is parallel to OA and $BC = \frac{3}{2}OA$. X is a point on OC such that $OX = \frac{2}{3}XC$. Y is the midpoint of BC .

(a) Express in terms of a and/or b , as simply as possible,

(i) \vec{AB} , [1]

$\vec{AB} = b - 2a$ ----- B1

(ii) \vec{OC} , [1]

$\vec{OC} = b + 3a$ ----- B1

(iii) \vec{OX} , [1]

$\vec{OX} = \frac{2}{5}(b + 3a)$ oe ----- B1

(iv) \vec{AX} , [1]

$\vec{AX} = \vec{AO} + \vec{OX}$

$= -2a + \frac{2}{5}b + \frac{6}{5}a$

$= -\frac{4}{5}a + \frac{2}{5}b$ ----- M1

(b) Write down two facts about the points A , X and B . [2]

$\vec{AB} = \frac{5}{2}\left(\frac{2}{5}b - \frac{4}{5}a\right)$

$= \frac{5}{2}\vec{AX}$ ----- B1

A , X , and B are collinear. --- B1

- (c) (i) \overline{AY} produced meets \overline{OB} produced at a point Z . Given that $\overline{AZ} = h\overline{AY}$, express \overline{AZ} in terms of a , b and h . [3]

$$\begin{aligned}\overline{AZ} &= h\overline{AY} \\ \overline{AY} &= \overline{AB} + \overline{BY} \text{-----M1} \\ &= b - \frac{1}{2}a \text{-----M1} \\ \overline{AZ} &= hb - \frac{1}{2}ha \text{-----A1}\end{aligned}$$

- (ii) Given also that $\overline{OZ} = k\overline{OB}$, express \overline{AZ} in terms of a , b , and k . [1]

$$\overline{AZ} = -2a + kb \text{-----B1}$$

- (iii) Hence, show that $h = 4$ and $k = 4$. [2]

$$\begin{aligned}bh - \frac{1}{2}ha &= 2a + kb \\ \text{Comparing} \\ h = 4, k = 4 &\text{-----A1, A1}\end{aligned}$$

- (d) Find the value of

(i) $\frac{\text{area of } \triangle OAX}{\text{area of } \triangle OAC}$, [1]

$$\frac{\text{area of } \triangle OAX}{\text{area of } \triangle OAC} = \frac{2}{5} \text{-----B1}$$

(ii) $\frac{\text{area of } \triangle OBX}{\text{area of } \triangle ABC}$, [1]

$$\frac{\text{area of } \triangle OBX}{\text{area of } \triangle ABC} = \frac{3}{5} \times \frac{2}{3} = \frac{2}{5} \text{-----B1}$$

- 6 In the diagram, P and Q are the bases of two lighthouses such that P is located 40 km due north of Q .

A is a boat 30 km from P and on a bearing of 055° from P .



- (a) Find the distance AQ . [3]

$$\begin{aligned}AQ^2 &= 30^2 + 40^2 - 2(30)(40)\cos 125^\circ \text{-----M1M1} \\ &= 2500 - 2400\cos 125^\circ \\ AQ &= 62.26221525\dots \\ AQ &= 62.3 \text{ km (3 sf)-----A1}\end{aligned}$$

- (b) Find the bearing of A from Q . [2]

$$\begin{aligned}\frac{\sin \angle PQA}{30} &= \frac{\sin \angle APQ}{62.26221525} \\ \sin \angle PQA &= \frac{30 \times \sin 125^\circ}{62.26221525} \\ \angle PQA &= 23.2469296^\circ \\ \text{Bearing of } A \text{ from } Q &= 023.2^\circ.\end{aligned}$$

Light from P can be seen within 20 km radius of P , beyond which the light becomes too faint to be seen. When the boat moves from A to Q , X and Y are the positions on the boat's journey which are 20 km from P .

(c) Calculate

(i) the shortest distance of the boat from P . [2]

$$\angle PQX = \angle PQA = 23.2469296^\circ$$

$$\sin \angle PQX = \frac{h}{40} \text{-----} M1$$

$$h = 15.78778476 \text{ km}$$

$$h = 15.8 \text{ km} \text{-----} A1$$

(ii) the **smallest** angle of elevation of the lighthouse P from the boat as it travels from X to Y , given that the height of lighthouse P is 600m. [2]

smallest angle of elevation

$$= \tan^{-1} \left(\frac{600}{20000} \right) \text{-----} M1$$

$$= 1.7183 \dots$$

$$= 1.7^\circ \text{-----} A1$$

7 The diagram shows two roads XY and YZ meeting at point Y . The roads are perpendicular to each other. $YX = 45 \text{ km}$ and $YZ = 25 \text{ km}$.

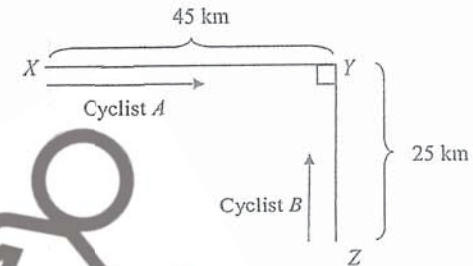

Cyclist A is travelling from point X towards point Y at a constant speed of 20 km/h. Cyclist B is travelling from point Z towards point Y at a constant speed of 10 km/h.

(a) Write down an expression, in terms of t , for the distance in kilometres

(i) between cyclist A and point Y , after t hours, [1]

$$(45 - 20t) \text{ km}$$

(ii) between cyclist B and point Y , after t hours. [1]

$$(25 - 10t) \text{ km}$$

(b) Form an expression, in terms of t , for the shortest distance, d , between the two cyclists and show that it reduces to $\sqrt{10t^2 - 46t + 53}$. [4]

Hence find the shortest distance between the two cyclists after 15 minutes.

$$d^2 = (45 - 20t)^2 + (25 - 10t)^2 \text{-----} M1$$

$$d = \sqrt{2025 - 1800t + 400t^2 + 625 - 500t + 100t^2}$$

$$= \sqrt{500t^2 - 2300t + 2650} \text{-----} A1$$

At $t = 0.25$ hour,

$$d = \sqrt{500(0.25)^2 - 2300(0.25) + 2650} \text{-----} M1$$

$$= 45.893 \dots$$

$$= 45.9 \text{ km} \text{-----} A1$$

- (c) The two cyclists are 10 km apart at a certain instant, t hours.
Form a quadratic equation in terms of t and show that it reduces to $10t^2 - 46t + 51 = 0$.

[2]

$$10 = \sqrt{500t^2 - 2300t + 2650} \text{-----M1}$$

$$100 = 500t^2 - 2300t + 2650$$

$$500t^2 - 2300t + 2650 = 0$$

$$20t^2 - 92t + 102 = 0$$

$$10t^2 - 46t + 51 = 0 \text{-----B1}$$

- (d) Given that $t < 2$, find the time, in minutes, when the two cyclists are 10 km apart.
Correct your answer to 3 significant figures.

[3]

$$10t^2 - 46t + 51 = 0$$

$$t = \frac{-(-46) \pm \sqrt{(-46)^2 - 4(10)(51)}}{2(10)} \text{-----M1}$$

$$= \frac{46 \pm \sqrt{76}}{20}$$

$$= 2.73588... \text{ or } 1.8641... \text{-----A1}$$

Hence $t = 1.8641... = 112$ minutes (3 sf)-----A1

- 8 A scientist wanted to test the effect of different music on the growth of plants.
80 *Rosa chinensis* plants were exposed to Beethoven's Ninth Symphony, and their growth were observed over a period of 10 days.
The cumulative frequency curve below shows the increase in the height of the plants at the end of 10 days.

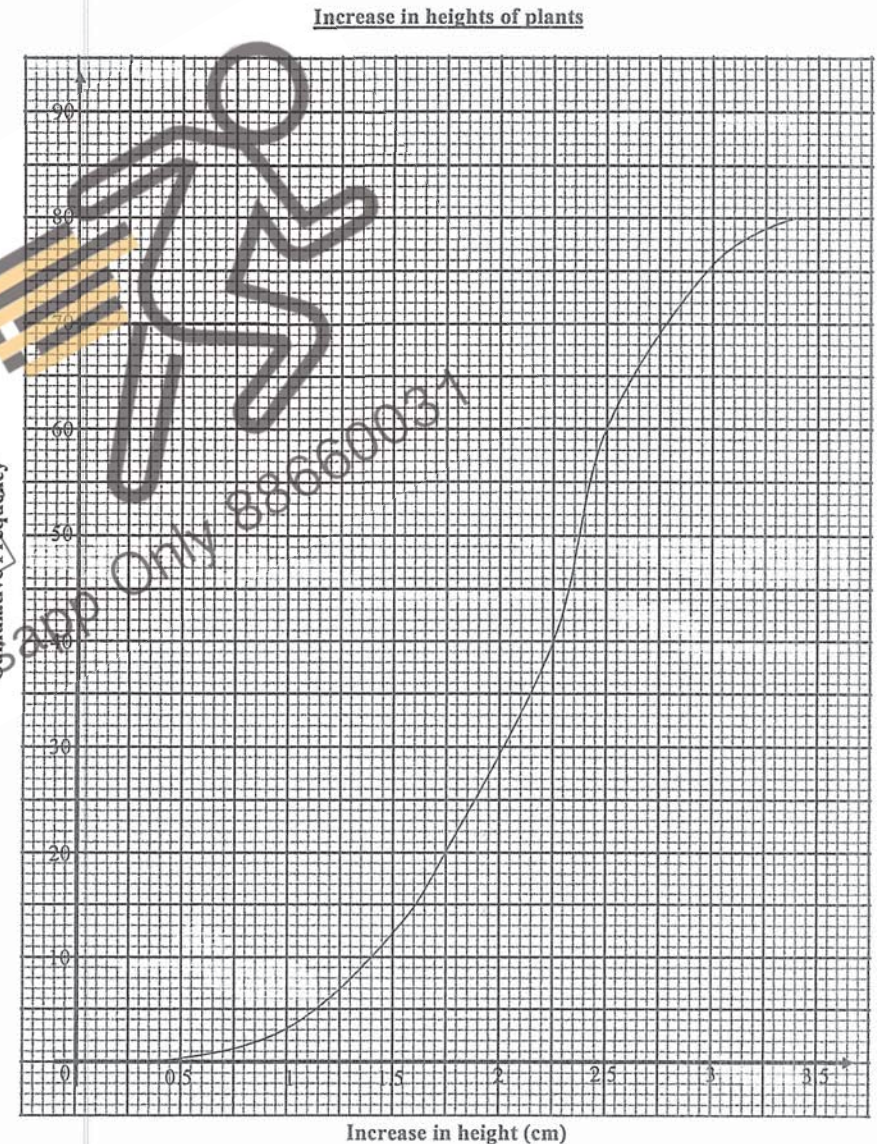

- (a) Find
(i) the median increase in the height of the plants, [1]

2.25 cm --- B1

- (ii) the interquartile range, [2]

$2.5 - 1.75 = 0.75$ cm --- M1, A1

- (iii) the 90th percentile. [2]

$$90^{\text{th}} \text{ percent} = \frac{90}{100} \times 80 \text{ --- M1}$$

$$= 72$$

90th percentile = 2.85 cm --- A1

(all answers ± 0.025)

- (b) Another group of 80 *Rosa chinensis* plants were exposed to Bach's Goldberg Variations, and their growth were also observed over a period of 10 days. The box-and-whisker plot below shows the increase in the heights of the plants after 10 days.



- (i) Describe how the cumulative frequency graph of the growth of the 80 plants exposed to Bach's Goldberg Variations will differ from that of those exposed to Beethoven's Ninth Symphony. [1]

The cumulative frequency graph of the growth of plants exposed to Bach will be **less steep in the middle/steeper at the upper quartile/wider range/broader range** compared to that of plants exposed to Beethoven. --- B1

OR

The middle of the cumulative frequency graph of the growth of plants exposed to Bach is **shifted to the right** compared to that of plants exposed to Beethoven. --- B1

- (ii) Make two comparisons between the growths of the plants under the two conditions. [2]

The plants grow **better** when exposed to Bach **on average** compared to when exposed to Beethoven as the **median increase in heights** of the plants when exposed to Bach is **higher** than those exposed to Beethoven. --- B1
The increase in heights of the plants are **more spread** when exposed to Bach than when exposed to Beethoven as the **interquartile range is larger** when exposed to Bach than when exposed to Beethoven. --- B1

- 9 The variables x and y are connected by the equation $y = \frac{1}{2x^2} + 0.1x^2 - 3$. The table below shows some values of x and the corresponding values of y , correct to 2 decimal places.

x	0.5	1	1.5	2	3	4	5	6
y	-0.98	-2.40	-2.55	-2.48	-2.04	-1.37	p	0.61

- (a) Find the value of p . [1]

$p = -0.48$ --- B1

- (b) In the space provided on the next page, using a scale of 2 cm to represent 1 unit on the horizontal axis and 2 cm to represent 0.5 units on the vertical axis, draw the graph of $y = \frac{1}{2x^2} + 0.1x^2 - 3$ for $0.5 \leq x \leq 6$. [3]

Refer to attached
(minus 1 if the graph turns to the left or is vertical at $x = 0.5$)

- (c) Using your graph, write down the solution(s) to the equation $\frac{1}{2x^2} + 0.1x^2 - 1.5 = 0$. [2]
 $x = 0.6$ or 3.8 ± 0.1 --- B2

- (d) By drawing a tangent, find the gradient of the curve at $x = 4$. [2]

Tangent drawn. --- M1

$$\text{gradient} = \frac{-0.25 - (-2.15)}{5.4 - 3}$$

$$= 0.792 \text{ (} 0.7 - 0.85 \text{) (actual} = 0.784375 \text{)} \text{ --- A1}$$

- (e) By drawing a suitable straight line on the same axes, solve the equation $\frac{1}{2x^2} + 0.1x^2 - 0.5x = 0$ [3]

$$\frac{1}{2x^2} + 0.1x^2 - 0.5x = 0$$

$$\frac{1}{2x^2} + 0.1x^2 - 3 = 0.5x - 3$$

$$\therefore \text{Draw } y = 0.5x - 3 \text{ --- M1}$$

Correctly drawn graph --- B1

$$x = 1.1 \text{ or } 4.95 \pm 0.1 \text{ --- B1}$$

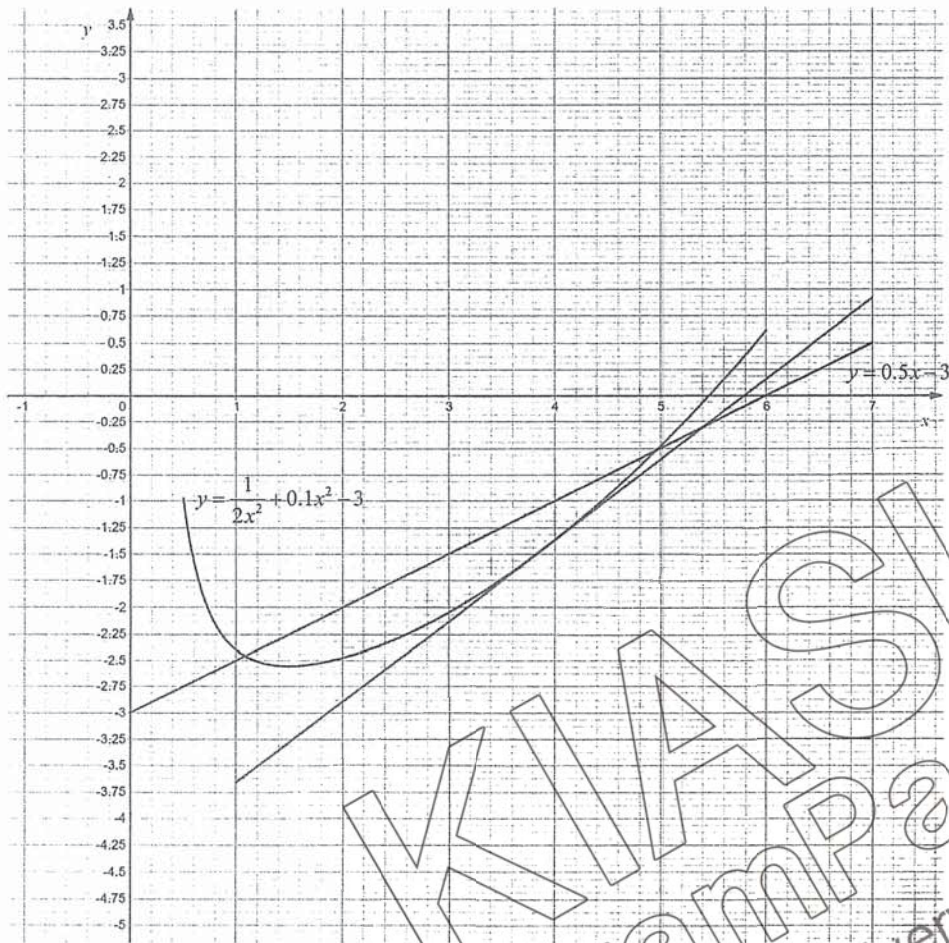

KIASU
ExamPaper
Islandwide Delivery | Whatsapp Only 88660031

10 A right conical container of capacity $24\pi \text{ cm}^3$ and vertical angle 60° is completely filled with water. The height of the container is $h \text{ cm}$ and the base radius is $r \text{ cm}$.

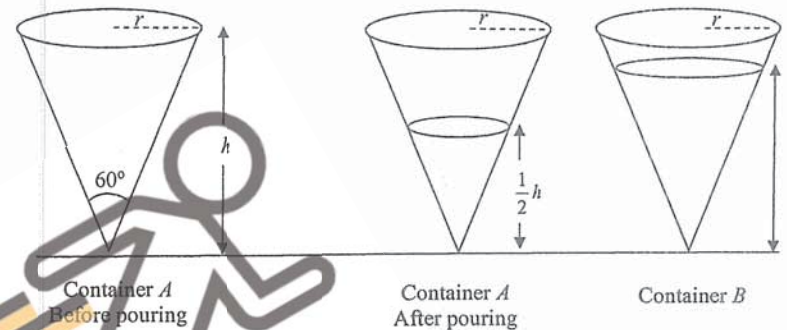

(a) Find the value of r and of h .

$$\frac{1}{3}\pi r^2 h = 24\pi \text{ ----- M1}$$

$$r^2 h = 72$$

$$\tan 30^\circ = \frac{r}{h} \text{ ----- M1}$$

$$h = \frac{r}{\tan 30^\circ}$$

$$\text{Hence, } r^3 = 72 \tan 30^\circ \text{ ----- M1}$$

$$r = \sqrt[3]{72 \tan 30^\circ} = 3.4610\dots = 3.46 \text{ cm ----- A1}$$

$$h = 6 \text{ cm ----- A1}$$

OR

$$r^2 + h^2 = (2r)^2$$

$$r^2 = \frac{h^2}{3} \text{ --- (1)}$$

$$\frac{1}{3}\pi r^2 h = 24\pi \text{ --- (2)}$$

sub (1) into (2):

$$\frac{1}{3}\pi \left(\frac{h^2}{3}\right) h = 24\pi$$

$$h^3 = 216$$

$$h = 6 \text{ cm}$$

$$r = \sqrt{\frac{6^2}{3}}$$

$$= 3.46 \text{ cm}$$

[5]

The water in the container is poured into another identical container B so that the depth of water in container A is $\frac{1}{2}h$ cm.

(b) Find the volume of water in container B in terms of π .

[2]

$$\frac{V_A}{\text{original volume}} = \left(\frac{1}{2}\right)^3 = \frac{1}{8} \text{---M1}$$

$$\text{Volume of water in container } B = \frac{7}{8} \times 24\pi = 21\pi \text{ cm}^3 \text{---A1}$$

OR

$$\text{volume remaining} = \frac{1}{3}\pi \left(\frac{\sqrt{12}}{2}\right)^2 \left(\frac{6}{2}\right) = 3\pi$$

$$\text{volume in } B = 24\pi - 3\pi = 21\pi \text{ cm}^3$$

11 A class of students plan to sell breakfast sets during the National Day carnival in order to raise funds for Food Bank Singapore.

Each breakfast set consists of 2 scrambled eggs, 2 slices of toast, 2 sausages, and a cup of coffee.

The students estimate that they will sell 250 breakfast sets.

Item	Description	Unit cost
Eggs	Pasar Fresh Eggs (10 per pack)	\$1.80
	Pasar Fresh Eggs (30 per pack)	\$4.35
Bread	Sunshine Enriched Soft White Bread (14 slices)	\$1.80
	FairPrice Wholemeal Bread (12 slices)	\$1.55
Sausages	Tierney's Chicken Hot Dog (10 per pack)	\$5.25
	FairPrice Sausages (6 per pack) (\$0.35 off per 2 packs)	\$3.20
Coffee	Nescafe 3 in 1 Instant Coffee (35 per pack) (Buy 5 get 1 free)	\$6.15
	Gold Roast 3 in 1 Coffeemix (25 per pack)	\$3.95

(a) Find the lowest possible total cost of the ingredients for the breakfast sets.

[5]

	Cost		
Eggs	10 per pack (50)(1.80) = 90	30 per pack (17)(4.35) = 73.95	Mix (16)(4.35) + (2)(1.80) = 73.20
Bread	Sunshine (36)(1.80) = 64.80	FairPrice (42)(1.55) = 65.10	Mix (35)(1.80) + (1)(1.55) = 64.55 (28)(1.80) + (9)(1.55) = 64.35 (34)(1.80) + (2)(1.55) = 64.30 (10)(1.80) + (30)(1.55) = 64.50
Sausages	Tierney's (50)(5.25) = 262.50	FairPrice (84)(3.20) - (42)(0.35) = 254.10	Mix (82)(3.20) - (41)(0.35) + (1)(5.25) = 253.30 (80)(3.20) - (40)(0.35) + (2)(5.25) = 252.5
Coffee	Nescafe (7)(6.15) = 43.05	Gold Roast (10)(3.95) = 39.50	Mix (5)(6.15) + (2)(3.95) = 38.65

B1 for each correct choice for each item.

$$\text{total cost} = 73.20 + 64.30 + 252.50 + 38.65 = \$428.65 \text{---A1}$$

(not lowest cost per item used: M1 for each correct item, no A1)

(insufficient quantities purchased: M0)

- (b) The school provides \$200 in funding for the students, and up to 30% of the sales can be used to cover for their expenses, while the remaining goes to the charity. The students also wish to raise at least \$600 for charity. Find the minimum they must charge for each breakfast set (to the nearest ten cents). Justify your answer, showing all necessary workings clearly. State an assumption you have made in your calculations. [4]

$$\text{min charge to raise } \$600 = \frac{(428.65 - 200) + 600}{250} = \$3.3146 \quad \text{--- M1 (ECF their (a))}$$

$$\left(\frac{30}{100}\right)(3.3146)(250) = 248.595 > 431.60 - 200 \quad \text{--- M1 (ECF their (a))}$$

$$\therefore \text{min charge} = \$3.40 \quad \text{--- A1}$$

Assume no cost incurred for cooking. (or any reasonable) --- B1

OR

$$\text{min charge to raise } \$600 = \frac{(428.65 - 200) + 600}{250} = \$3.3146 \quad \text{--- M1 (ECF their (a))}$$

$$\text{min charge to cover expenses} = \left[\frac{(428.65 - 200) \times 100}{30} \right] \div 250 = \$3.048 \quad \text{--- M1 (ECF their (a))}$$

$$\therefore \text{min charge} = \$3.40 \quad \text{--- A1}$$

Assume no cost incurred for cooking. (or any reasonable) --- B1

Alternative assumptions:

- 1) No accidents that result in wastage during the event
- 2) No free samples were given out
- 3) All 250 sets were sold



KIASU
ExamPaper
Islandwide Delivery | Whatsapp Only 88660031